



CHUCK

2 Jaw Large Thru-Hole High Speed Power Chuck BT200 series

For gripping Irregular shaped components

* CE correspondence



Standard Chuck

Gripping Examples

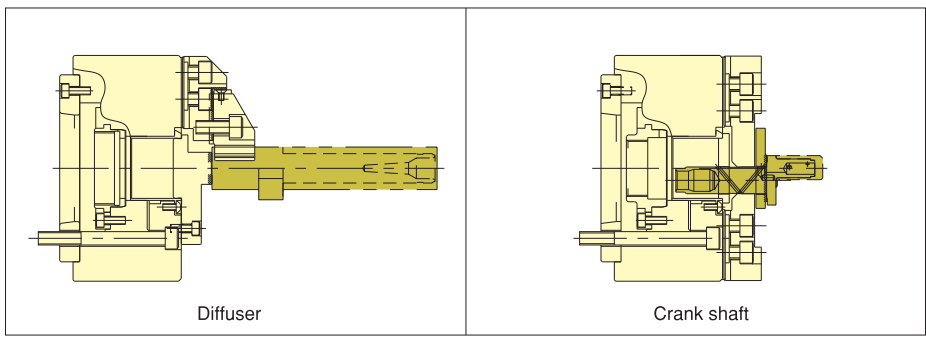

Dimensional Drawings

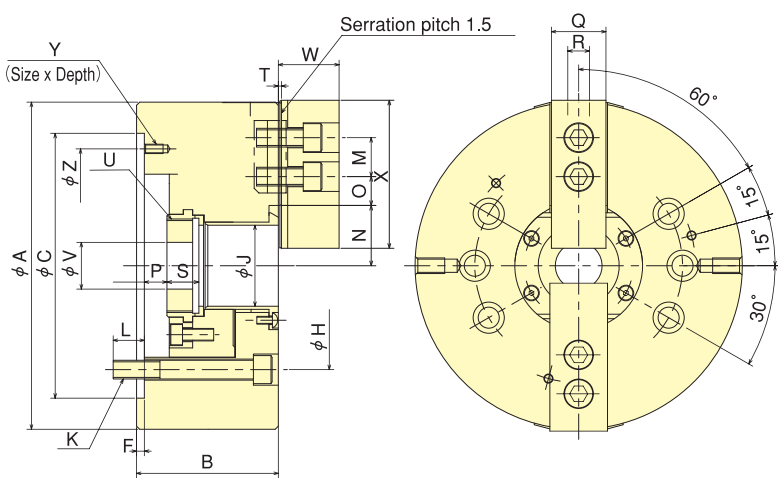

Gripping Characteristic Graphs

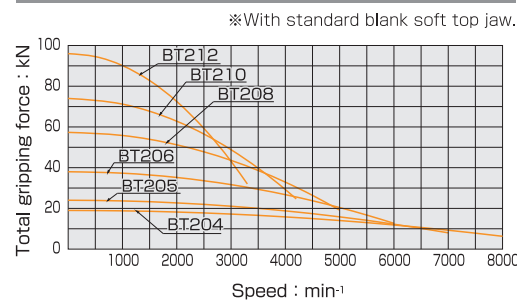

Dimensions ※Mounting bolt P. C. D. for BT204 & BT205 : each 60° from jaw centre : 4 pcs. ※Blank draw nut equipped.

Model	A	B	C (H6)	F	H	J	K	L	M	N max.	N min.	O max.	O min.	P max.	P min.	Q	R	S	T	U max.	V	W	X	Y	Z
BT204	110	59	85	4	70.6	26	4-M10	15.5	14	23	20.3	11.25	6.75	3.5	- 6.5	23	10	17.5	2	M32x1.5	12	24	49.5	-	-
BT205	135	60	110	4	82.55	33	4-M10	15	14	26.5	23.8	19.75	7.75	1	- 9	23	10	20	2	M40x1.5	12	26	54	-	-
BT206	169	81	140	5	104.8	45	6-M10	16	20	32	29.25	22.75	9.25	11	- 1	26	12	19	2	M55x2	20	29	66	M6x10	116
BT208	210	91	170	5	133.4	52	6-M12	20	25	38.7	35	30	15	14.5	- 1.5	35	14	20.5	2	M60x2	30	39	95	M6x12	150
BT210	254	100	220	5	171.4	75	6-M16	22	30	51	46.6	34	14.5	8.5	- 10.5	40	16	25	2	M85x2	45	43	110	M8x15	190
BT212	304	110	220	6	171.4	91	6-M16	23	30	61.3	56	45.75	15.75	8	- 15	50	21	28	2	M100x2	50	51	111	M8x15	190

Specifications

※Max speed is shown using actual test data.

Model	Thru-Hole mm	Gripping range mm Max. Min.	Jaw Stroke (diameter) mm	Plunger Stroke mm	Max. Draw Bar Pull Force kN (kgf)	Max. Gripping Force kN (kgf)	Max. Speed min ⁻¹	Net Weight with Soft top jaws kg	Moment of inertia kg·m ²	Matching Cylinder	Max. pressure MPa (kgf/cm ²)	Matching Soft top jaw
BT204	26	110 7	5.4	10	9.3 (948)	19 (1937)	8000	3.8	0.006	F0933H	1.94 (19.8)	SB04N1T
BT205	33	135 12	5.4	10	11.7 (1193)	24 (2447)	7000	6.5	0.017	F0933H	2.38 (24.3)	SB05N1T
BT206	45	169 14	5.5	12	14.5 (1479)	38 (3875)	6000	11.5	0.056	S1246	1.85 (18.9)	SB06L1T
BT208	52	210 14	7.4	16	23.2 (2366)	57.3 (5843)	5000	21.3	0.165	S1552	1.80 (18.4)	SB08A1T
BT210	75	254 31	8.8	19	28.5 (2906)	74 (7546)	4200	33.5	0.308	S1875	1.80 (18.4)	SB10A1T
BT212	91	304 34	10.6	23	36.7 (3742)	96 (9789)	3300	52	0.700	S2091	1.81 (18.5)	SB12N1T

※Altering Back Plate enables to change over 3-Jaw Chuck into 2-Jaw Chuck.