

Rigid and Accurate ID Workpiece Gripping



KEM series

ID clamping offers full OD part access

Parallel expansion for optimum accuracy and grip force

Expanding sleeves are fully sealed for complete protection

■ **High Accuracy & Rigidity**

Pull-back design draws the workpiece securely against a part locator for 'dual-contact' rigidity

■ **Modular Design**

All Mandrel models have a common flange configuration, enabling full interchangeability with all back bodies

■ **Customised systems available**

Larger sizes on the market – up to 635mm ID gripping

1/2 length sleeves, extended length sleeves and dual sleeves are available for supporting a wide range of parts

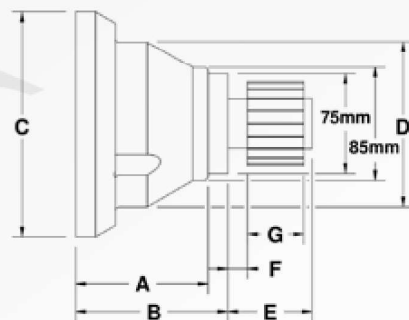

MANDREL SPECIFICATIONS

Mandrel Model	Mandrel Gripping Range mm		Sleeve Gripping Range mm	Maximum Pull Force kN	Maximum Gripping Force kN
	Min	Max			
KEM-AS	12.4	22.4	0.5	7	12.5
KEM-BS	15.9	29.1	0.5	10	17.8
KEM-CS	21.9	40.3	0.8	12	21.4
KEM-DS	28.3	51.5	0.8	18	32
KEM-ES	41.1	82.7	0.8	23	40.9

COMPLETE ASSEMBLY DIMENSIONS

Spindle Mount	A mm	B mm	C mm	D mm	E mm	F mm	G mm
A2-5	88	108	135	100			
A2-6	95	115	170	125			
140mm	83	103	160	100			
A2-8	100	120	210	125			

See Mandrel Chart Overleaf

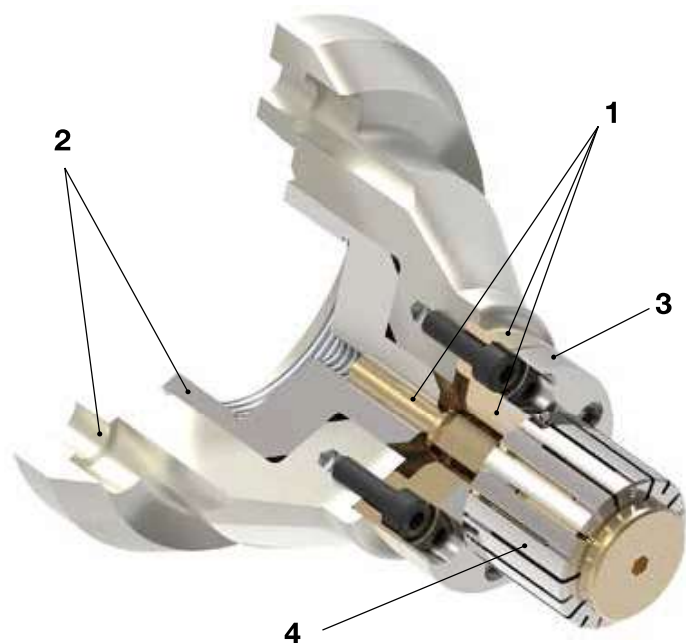

How to Order

1. Choose the appropriate mandrel model based upon the diameter(s) you plan to grip. All mandrels and bodies share a common mounting interface for full interchangeability. Each mandrel includes the expanding rod and an expanding rod adapter

2. Choose the part number to suit your spindle mount based upon the lathe spindle it will be mounted to. Just like with Kitagawa Europe Collet Chucks, each ID gripping system includes a drawtube connector that can be customised to your drawtube to ensure hassle-free installation

3. If required, choose part locator(s) to provide a banking surface for the workpiece

4. Choose the appropriate sleeve(s) based upon the diameter(s) you plan to grip

1. Choose the appropriate mandrel model

- Mandrel models are defined by their gripping range
- Expanding rod, expanding rod adapter, and mounting hardware included with each mandrel
- Order expanding sleeves separately

2. Choose the part number to suit your spindle mount

- The part number identifies the exact back body that provides a precision interface for connecting the mandrel to the spindle
- The part number includes mandrel, back body & blank drawtube connector (which can be machined by yourself or custom-machined by us) and mounting hardware
- Order sleeves, and part locators separately

3. Choose part locator

- Part locators are an optional accessory
- Locator bolts to the front of the mandrel and provides a square surface for the workpiece to locate against
- Wider locators available to accommodate short parts

KEM SERIES MANDREL MODELS

Mandrel Model	Mandrel Gripping Range mm		E mm	F mm	G mm	G (Flush) mm	Spindle Mount	Part Number
	Min	Max						
KEM-AS	12.4	22.4	64	14.5	22.1	25.4	A2-5	KEM-AS-A5
							A2-6	KEM-AS-A6
							A2-8	KEM-AS-A8
							Z140	KEM-AS-14
KEM-BS	15.9	29.1	46	15	27	31	A2-5	KEM-BS-A5
							A2-6	KEM-BS-A6
							A2-8	KEM-BS-A8
							Z140	KEM-BS-14
KEM-CS	21.9	40.3	52.1	15.5	32	36.6	A2-5	KEM-CS-A5
							A2-6	KEM-CS-A6
							A2-8	KEM-CS-A8
							Z140	KEM-CS-14
KEM-DS	28.3	51.5	59	15.2	38.1	43.8	A2-5	KEM-DS-A5
							A2-6	KEM-DS-A6
							A2-8	KEM-DS-A8
							Z140	KEM-DS-14
KEM-ES	41.1	82.7	64	14.7	43	49.3	A2-5	KEM-ES-A5
							A2-6	KEM-ES-A6
							A2-8	KEM-ES-A8
							Z140	KEM-ES-14

KEM SERIES PART LOCATOR

Fits Mandrel Model	Width mm	Outer Ø mm	Part Number
KEM-AS	12	39.9	KEM-AS-PL
KEM-BS	12	39.9	KEM-BS-PL
KEM-CS	12	75.0	KEM-CS-PL
KEM-DS	12	75.0	KEM-DS-PL
KEM-ES	12	75.0	KEM-ES-PL

4. Choose the appropriate expanding sleeve(s)

1/2 length sleeve, extended length & dual length sleeves available

KEM-AS					
STANDARD SLEEVE			FLUSH SLEEVE		
Nominal Sleeve Ø	Gripping Range mm	Part Number	Nominal Sleeve Ø	Gripping Range mm	Part Number
12.50	12.40 - 12.90	92.000.210.1250	16.50	16.40 - 16.90	92.001.210.1650
13.00	12.90 - 13.40	92.000.210.1300	17.00	16.90 - 17.40	92.001.210.1700
13.50	13.40 - 13.90	92.000.210.1350	17.50	17.40 - 17.90	92.001.210.1750
14.00	13.90 - 14.40	92.000.210.1400	18.00	17.90 - 18.40	92.001.210.1800
14.50	14.40 - 14.90	92.000.210.1450	18.50	18.40 - 18.90	92.001.210.1850
15.00	14.90 - 15.40	92.000.210.1500	19.00	18.90 - 19.40	92.001.210.1900
15.50	15.40 - 15.90	92.000.210.1550	19.50	19.40 - 19.90	92.001.210.1950
16.00	15.90 - 16.40	92.000.210.1600	20.00	19.90 - 20.40	92.001.210.2000
			20.50	20.40 - 20.90	92.001.210.2050
			21.00	20.90 - 21.40	92.001.210.2100
			21.50	21.40 - 21.90	92.001.210.2150
			22.00	21.90 - 22.40	92.001.210.2200

KEM-BS					
STANDARD SLEEVE			FLUSH SLEEVE		
Nominal Sleeve Ø	Gripping Range mm	Part Number	Nominal Sleeve Ø	Gripping Range mm	Part Number
16.00	15.90 - 16.40	92.050.210.1600	22.00	21.90 - 22.70	92.051.210.2200
16.50	16.40 - 16.90	92.050.210.1650	22.80	22.70 - 23.50	92.051.210.2280
17.00	16.90 - 17.40	92.050.210.1700	23.60	23.50 - 24.30	92.051.210.2360
17.50	17.40 - 17.90	92.050.210.1750	24.40	24.30 - 25.10	92.051.210.2440
18.00	17.90 - 18.40	92.050.210.1800	25.20	25.10 - 25.90	92.051.210.2520
18.50	18.40 - 18.90	92.050.210.1850	26.00	25.90 - 26.70	92.051.210.2600
19.00	18.90 - 19.40	92.050.210.1900	26.80	26.70 - 27.50	92.051.210.2680
19.50	19.40 - 19.90	92.050.210.1950	27.60	27.50 - 28.30	92.051.210.2760
20.00	19.90 - 20.40	92.050.210.2000	28.40	28.30 - 29.10	92.051.210.2840
20.50	20.40 - 20.90	92.050.210.2050			
21.00	20.90 - 21.40	92.050.210.2100			
21.50	21.40 - 21.90	92.050.210.2150			
22.00	21.90 - 22.40	92.050.210.2200			

KEM-CS					
STANDARD SLEEVE			FLUSH SLEEVE		
Nominal Sleeve Ø	Gripping Range mm	Part Number	Nominal Sleeve Ø	Gripping Range mm	Part Number
22.00	21.90 - 22.70	92.100.210.2200	28.40	28.30 - 29.10	92.101.210.2840
22.80	22.70 - 23.50	92.100.210.2280	29.20	29.10 - 29.90	92.101.210.2920
23.60	23.50 - 24.30	92.100.210.2360	30.00	29.90 - 30.70	92.101.210.3000
24.40	24.30 - 25.10	92.100.210.2440	30.80	30.70 - 31.50	92.101.210.3080
25.20	25.10 - 25.90	92.100.210.2520	31.60	31.50 - 32.30	92.101.210.3160
26.00	25.90 - 26.70	92.100.210.2600	32.40	32.30 - 33.10	92.101.210.3240
26.80	26.70 - 27.50	92.100.210.2680	33.20	33.10 - 33.90	92.101.210.3320
27.60	27.50 - 28.30	92.100.210.2760	34.00	33.90 - 34.70	92.101.210.3400
28.40	28.30 - 29.10	92.100.210.2840	34.80	34.70 - 35.50	92.101.210.3480
			35.60	35.50 - 36.30	92.101.210.3560
			36.40	36.30 - 37.10	92.101.210.3640
			37.20	37.10 - 37.90	92.101.210.3720
			38.00	37.90 - 38.70	92.101.210.3800
			38.80	38.70 - 39.50	92.101.210.3880
			39.60	39.50 - 40.30	92.101.210.3960

KEM-DS					
STANDARD SLEEVE			FLUSH SLEEVE		
Nominal Sleeve Ø	Gripping Range mm	Part Number	Nominal Sleeve Ø	Gripping Range mm	Part Number
28.40	28.30 - 29.10	92.150.210.2840	39.60	39.50 - 40.30	92.151.210.3960
29.20	29.10 - 29.90	92.150.210.2920	40.40	40.30 - 41.10	92.151.210.4040
30.00	29.90 - 30.70	92.150.210.3000	41.20	41.10 - 41.90	92.151.210.4120
30.80	30.70 - 31.50	92.150.210.3080	42.00	41.90 - 42.70	92.151.210.4200
31.60	31.50 - 32.30	92.150.210.3160	42.80	42.70 - 43.50	92.151.210.4280
32.40	32.30 - 33.10	92.150.210.3240	43.60	43.50 - 44.30	92.151.210.4360
33.20	33.10 - 33.90	92.150.210.3320	44.40	44.30 - 45.10	92.151.210.4440
34.00	33.90 - 34.70	92.150.210.3400	45.20	45.10 - 45.90	92.151.210.4520
34.80	34.70 - 35.50	92.150.210.3480	46.00	45.90 - 46.70	92.151.210.4600
35.60	35.50 - 36.30	92.150.210.3560	46.80	46.70 - 47.50	92.151.210.4680
36.40	36.30 - 37.10	92.150.210.3640	47.60	47.50 - 48.30	92.151.210.4760
37.20	37.10 - 37.90	92.150.210.3720	48.40	48.30 - 49.10	92.151.210.4840
38.00	37.90 - 38.70	92.150.210.3800	49.20	49.10 - 49.90	92.151.210.4920
38.80	38.70 - 39.50	92.150.210.3880	50.00	49.90 - 50.70	92.151.210.5000
39.60	39.50 - 40.30	92.150.210.3960	50.80	50.70 - 51.50	92.151.210.5080
40.40	40.30 - 41.10	92.150.210.4040			
41.20	41.10 - 41.90	92.150.210.4120			

KEM-ES					
STANDARD SLEEVE			FLUSH SLEEVE		
Nominal Sleeve Ø	Gripping Range mm	Part Number	Nominal Sleeve Ø	Gripping Range mm	Part Number
41.20	41.10 - 41.90	92.200.210.4120	50.80	50.70 - 51.50	92.201.210.5080
42.00	41.90 - 42.70	92.200.210.4200	51.60	51.50 - 52.30	92.201.210.5160
42.80	42.70 - 43.50	92.200.210.4280	52.40	52.30 - 53.10	92.201.210.5240
43.60	43.50 - 44.30	92.200.210.4360	53.20	53.10 - 53.90	92.201.210.5320
44.40	44.30 - 45.10	92.200.210.4440	54.00	53.90 - 54.70	92.201.210.5400
45.20	45.10 - 45.90	92.200.210.4520	54.80	54.70 - 55.50	92.201.210.5480
46.00	45.90 - 46.70	92.200.210.4600	55.60	55.50 - 56.30	92.201.210.5560
46.80	46.70 - 47.50	92.200.210.4680	56.40	56.30 - 57.10	92.201.210.5640
47.60	47.50 - 48.30	92.200.210.4760	57.20	57.10 - 57.90	92.201.210.5720
48.40	48.30 - 49.10	92.200.210.4840	58.00	57.90 - 58.70	92.201.210.5800
49.20	49.10 - 49.90	92.200.210.4920	58.80	58.70 - 59.50	92.201.210.5880
50.00	49.90 - 50.70	92.200.210.5000	59.60	59.50 - 60.30	92.201.210.5960
50.80	50.70 - 51.50	92.200.210.5080	60.40	60.30 - 61.10	92.201.210.6040
51.60	51.50 - 52.30	92.200.210.5160	61.20	61.10 - 61.90	92.201.210.6120
52.40	52.30 - 53.10	92.200.210.5240	62.00	61.90 - 62.70	92.201.210.6200
53.20	53.10 - 53.90	92.200.210.5320	62.80	62.70 - 63.50	92.201.210.6280
54.00	53.90 - 54.70	92.200.210.5400	63.60	63.50 - 64.30	92.201.210.6360
54.80	54.70 - 55.50	92.200.210.5480	64.40	64.30 - 65.10	92.201.210.6440
55.60	55.50 - 56.30	92.200.210.5560	65.20	65.10 - 65.90	92.201.210.6520
56.40	56.30 - 57.10	92.200.210.5640	66.00	65.90 - 66.70	92.201.210.6600
57.20	57.10 - 57.90	92.200.210.5720	66.80	66.70 - 67.50	92.201.210.6680
58.00	57.90 - 58.70	92.200.210.5800	67.60	67.50 - 68.30	92.201.210.6760
58.80	58.70 - 59.50	92.200.210.5880	68.40	68.30 - 69.10	92.201.210.6840
59.60	59.50 - 60.30	92.200.210.5960	69.20	69.10 - 69.90	92.201.210.6920
60.40	60.30 - 61.10	92.200.210.6040	70.00	69.90 - 70.70	92.201.210.7000
61.20	61.10 - 61.90	92.200.210.6120	70.80	70.70 - 71.50	92.201.210.7080
62.00	61.90 - 62.70	92.200.210.6200	71.60	71.50 - 72.30	92.201.210.7160
62.80	62.70 - 63.50	92.200.210.6280	72.40	72.30 - 73.10	92.201.210.7240
			73.20	73.10 - 73.90	92.201.210.7320
			74.00	73.90 - 74.70	92.201.210.7400
			74.80	74.70 - 75.50	92.201.210.7480
			75.60	75.50 - 76.30	92.201.210.7560
			76.40	76.30 - 77.10	92.201.210.7640
			77.20	77.10 - 77.90	92.201.210.7720
			78.00	77.90 - 78.70	92.201.210.7800
			78.80	78.70 - 79.50	92.201.210.7880
			79.60	79.50 - 80.30	92.201.210.7960
			80.40	80.30 - 81.10	92.201.210.8040
			81.20	81.10 - 81.90	92.201.210.8120
			82.00	81.90 - 82.70	92.201.210.8200

- All expanding sleeves are bonded to ensure they are fully sealed against coolant and chip penetration
- A double-angle design of KEM Expanding Mandrels provides parallel expansion of the sleeve for full-length workpiece contact and ensures positive release when the part is unclamped
- All expanding sleeves collapse 0.1mm below nominal ground sleeve diameter size to ensure easy workpiece loading and unloading

Manually Operated Expanding Mandrel Actuator



Load the KEM-MA manual actuator into a three jaw or collet chuck, gripping on the 38mm location spigot.



Actuate the power chuck to ensure KEM-MA is locked in position, adjust T.I.R as required.



Load a workpiece's internal diameter over the sleeve and actuate the mandrel using the key provided.



This cutaway image shows the unit's heavy-duty precision gear train. The mechanical advantage of the gears in combination with our unique double-angle expanding sleeves produces outstanding grip force on the workpiece.

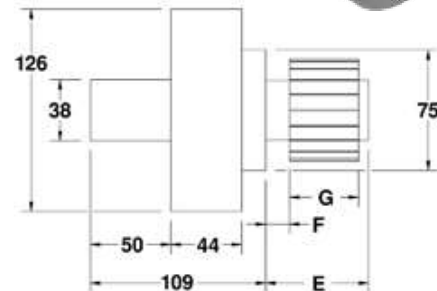

- KEM Series includes a manually-operated expanding mandrel actuator (called the KEM-MA) incorporating a precision-ground 38mm diameter location spigot that enables the unit to be held in any collet or jaw chuck, reducing setup times by eliminating the need to change the machine's three jaw chuck or collet chuck.
- These models utilise the same precision mandrels, expanding sleeves and locators as our CNC Expanding Mandrels see previous pages.
- Side-actuated with an included square-drive key means that this unit can accommodate parts with blind bores as well as those with thru-holes.
- Precision-ground for high accuracy in squareness and concentricity. If higher accuracy is needed the mandrel can be clocked-in once the unit is gripped in a chuck.
- Universal location spigot mount enables this ID workholding system to be easily moved from machine to machine as jobs require.
- A great option for low/medium-volume production. For high-production environments, use the Expanding Mandrels featured on the previous pages is recommended.
- When ordering, be sure to also order the appropriate threaded expanding rod adapter.

MANUALLY OPERATED EXPANDING MANDREL ACTUATOR

Description	Part Number
Manually Operated Expanding Mandrel Actuator	KEM-MA
Expanding Rod Adaptor – Fits Model KEM-AS	KEM-AS-ERA
Expanding Rod Adaptor – Fits Model KEM-BS	KEM-BS-ERA
Expanding Rod Adaptor – Fits Model KEM-CS	KEM-CS-ERA
Expanding Rod Adaptor – Fits Model KEM-DS	KEM-DS-ERA
Expanding Rod Adaptor – Fits Model KEM-ES	KEM-ES-ERA