

BP04

M/C BASE PLATE

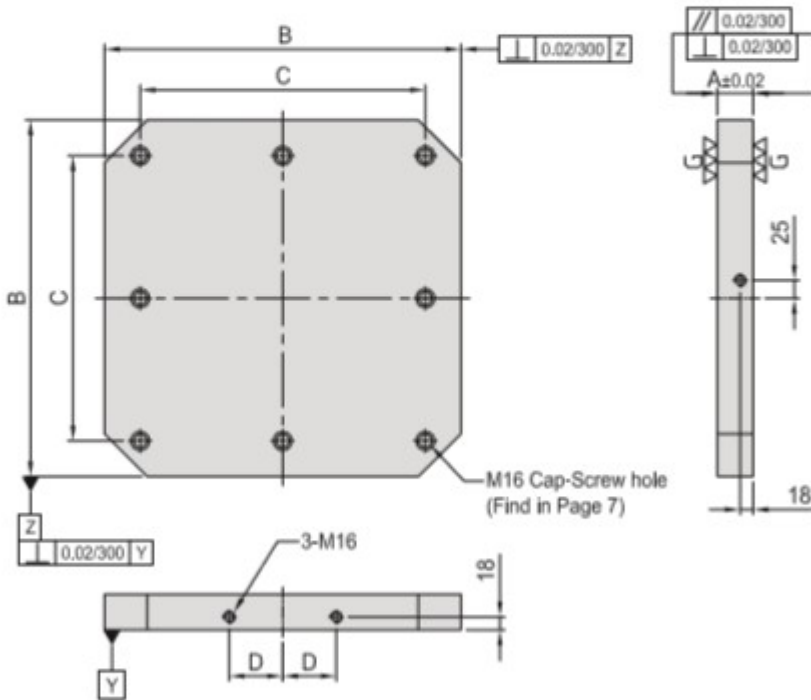

- Material / Finish:
Material: Cast Iron FC300(JIS) / GG30(DIN)
Heat treated (Normalized)
- Application: Horizontal Machining Center
- Features: Ready to accept a hole pattern for your special jig.



MODEL NO.	A	B	C	D	Mounting holes	kg
BP04-50400-0400	50	400	320	55	4	57
BP04-50500-0500	50	500	400	75	8	88
BP04-50630-0630	50	630	500	100	8	140
BP04-50800-0800	50	800	640	135	8	225

*Special Design Welcome !