

# BP14

## SUB-PLATE

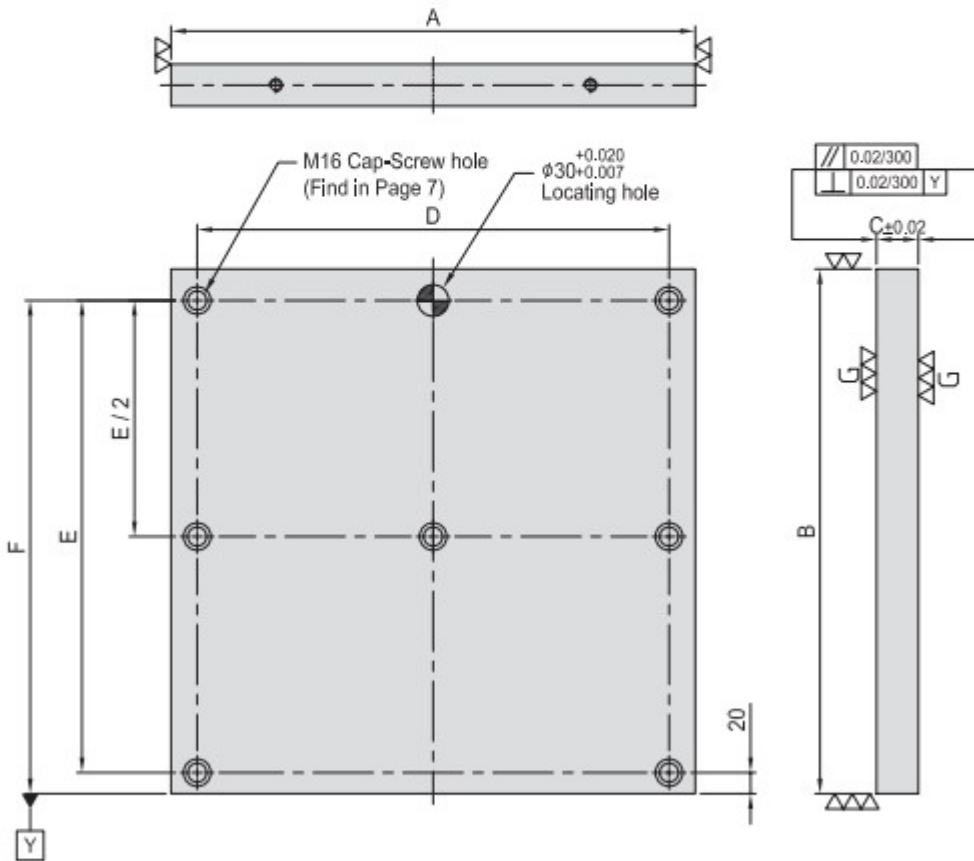

- Material / Finish:  
Material: Cast Iron FC300(JIS) / GG30(DIN)  
Heat treated (Normalized)
- Application: Modular quick change subplate, use with BP13.
- Features: Ready to accept a hole pattern for your special jig.



| MODEL NO.       | A   | B   | C  | D   | E   | F   | Mounting holes | kg  |
|-----------------|-----|-----|----|-----|-----|-----|----------------|-----|
| BP14-40400-0400 | 400 | 400 | 40 | 350 | 350 | 370 | 5              | 46  |
| BP14-40500-0500 | 500 | 500 | 40 | 450 | 450 | 470 | 7              | 72  |
| BP14-40630-0630 | 630 | 630 | 40 | 580 | 580 | 600 | 7              | 114 |
| BP14-50800-0800 | 800 | 800 | 50 | 750 | 750 | 770 | 7              | 232 |

\*Special Design Welcome !