



These Vise Jaws/Towers are designed to mount directly to your 4 or 6 inch vise elevating your workpiece into the 5 axis envelope. You already have the platform therefore this becomes a very simple and low cost solution. This is the only system on the market where you can loosen the vise and double the holding force!



The Towers are exceptionally versatile due to the incorporation of our TalonGrip™ and VersaGrip™ Grippers and Pitbull® clamps. Secure round or square stock easily by using a vise or by mounting towers directly to your t-slot or grid table. Low profile gripping saves material cost and no workpiece preparation saves machine and labor cost.

WISE APPLICATION

- ▶ Mount jaws to either 4 or 6 inch vise with MITEEBITE.COM facing outboard keeping mounting bolts loose.
- ▶ Determine which grippers will be used, install and tighten grippers hand tight. If VersaGrips™ are being used to grip round stock, place in outboard bores. Do not tighten screws at this point. Tighten vise lightly onto workpiece allowing jaws to center themselves, adjust VersaGrips™ and tighten gripper screws and mounting bolts for both jaws.
- ▶ Loosen vise jaw for load/unload clearance of workpiece. Install support/pivot bolt.
- ▶ Setup is complete. Tighten support bolt allowing grippers to penetrate .010-.060" on material < 40Rc.
- ▶ For additional holding force, loosen vise handle which will eliminate any jaw lift that may have occurred and depending on amount of torque can increase pressure to over 9,000 lbs.

T-SLOT & GRID TABLE APPLICATION

- ▶ Using vertical counter bores on outboard edges of jaws, install mounting bolts into t-nuts or grid plate and adjust accordingly. Do not tighten at this time.
- ▶ Select appropriate support bolts and install in upper horizontal counter bore and thread into opposite tower.
- ▶ Select grippers based on configuration suggestions below.
- ▶ Place workpiece between jaws and lightly tighten upper support bolt until all grippers contact workpiece. Tighten vertical mounting bolts.
- ▶ Loosen upper support bolt 1 full turn or until adequate workpiece clearance is obtained.
- ▶ Upper support bolt is now the "drive bolt" for securing and releasing workpiece.
- ▶ Any size t-nuts can be utilized. We provide 16mm t-nuts (most popular size) which also fits 5/8 t-slots.

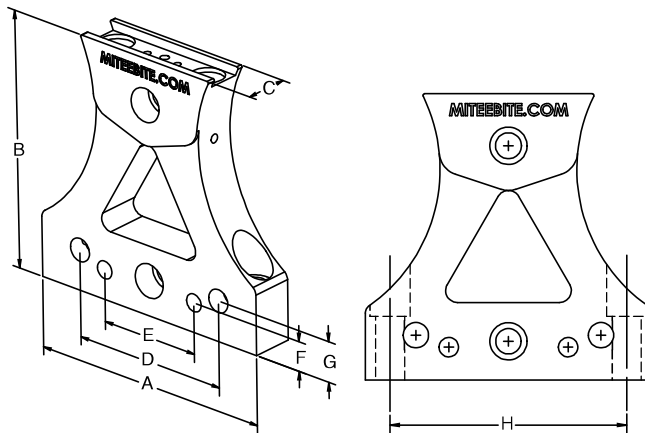

GRIPPER CONFIGURATIONS

- ▶ Round stock: use 4 VersaGrips™, two in each outboard bore. Adjust so all "points" make contact simultaneously. If small diameter workpiece, two parts may be held at one time.
- ▶ Maximum of 8 TalonGrips™ can be used, 4 in each jaw for maximum line contact.
- ▶ If down force is necessary or additional holding force use 2 Pitbull® clamps. One in the center of each jaw and one TalonGrip™ on each side of Pitbull® clamps. Tighten jaws into grippers then tighten each Pitbull® clamp.

COMBO KIT CONTENTS:

- 2 Jaws
- 4 Talongrip™ 3/4" grippers with M5 screws
- 4 Versagrip™ grippers with M5 screws
- 1 Talongrip™ 3/4" stop with M5 screw
- 2 Pitbull® blunt edge clamps with M6 screws
- 2 M12 x 200mm support bolts
- 2 M12 x 100mm support bolts
- 2 M12 x 65mm support bolts
- 4 M12 x 55mm mounting bolts
- 4 M12 x 16mm T-nuts

Part No.	Description	Vise size	Mtg. Bolts	A	B	C	D	E	F	G	H
32266	6" jaw set	4 or 6"	M12x55mm SHCS	6.00"	6.00"	1.06"	3.88"	2.50"	0.69"	0.94"	4.96"
	150mm Jaw Set	100mm/150mm		150.00mm	150.00mm	26.92mm	98.55mm	63.50mm	17.53mm	23.88mm	125.98mm

PATENT PENDING #62/257,028