

Overview of Automation

The System Development with the Systems Integrator

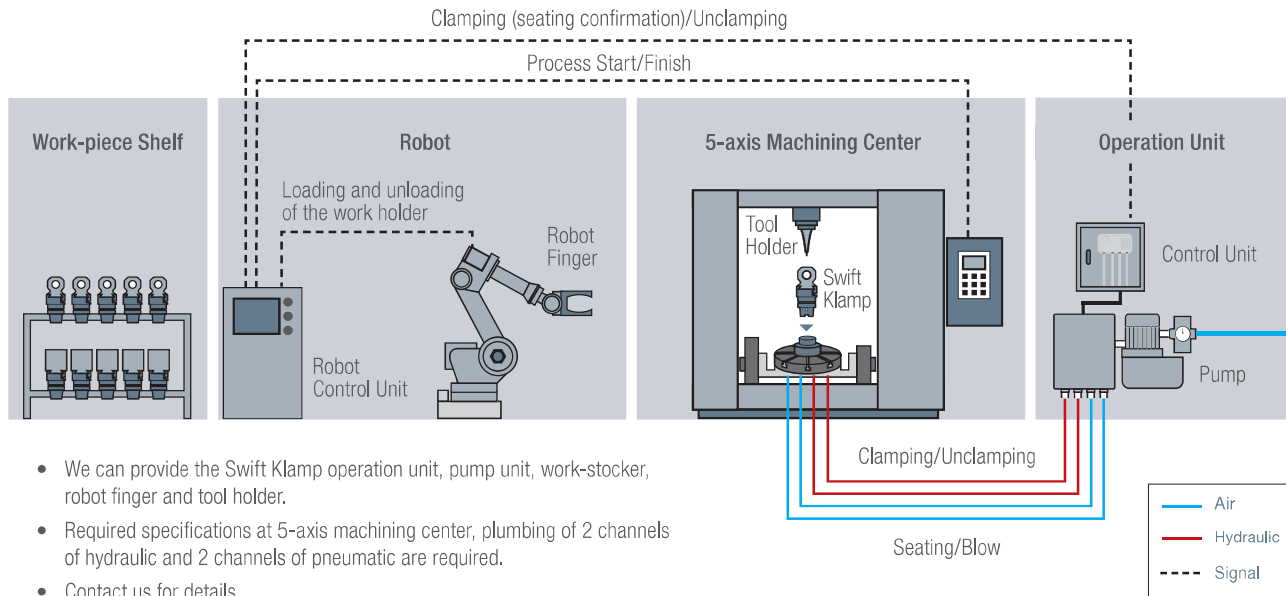

Hydraulic Automatic Clamping Head (Automatic Exchange)

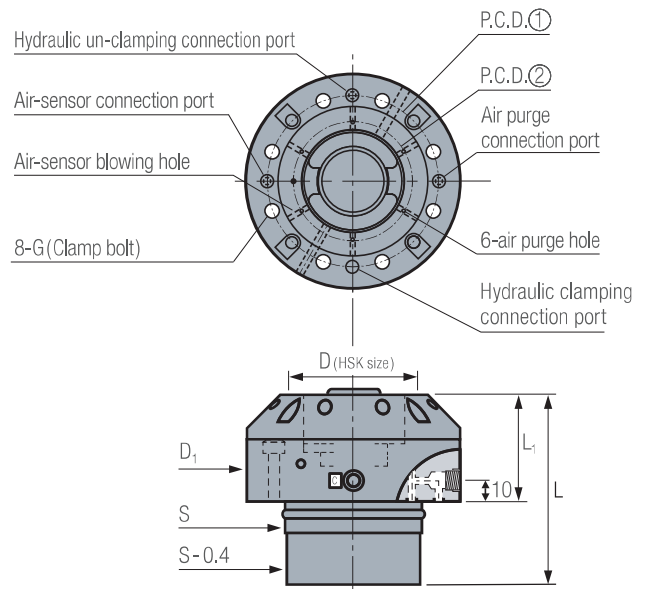

Part No.	HSK Type	L	ØD	ØD ₁	ØS _(ø6)	L ₁	G	PCD ₁	PCD ₂	Clamping Force kN	Max Loading Weight	Kg
AHK-A40-64	HSK-A40	64	40	70	45	35	M5x20	55	35	6	50	1.1
AHK-A63-89	HSK-A63	89	63	100	65	50	M6x30	80	55	24	140	3.1
AHK-A100-139	HSK-A100	139	100	140	100	80	M8x45	120	88	55	640	9.7

Note Hydraulic capacity: 3.5MPa