

Manual Clamping Head (Manual Exchange)

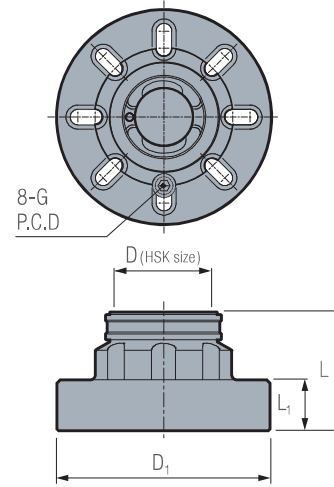

| Part No. | HSK Type | L | ØD | ØD ₁ | L ₁ | G | PCD | Clamping Force kN | Kg |
|--------------|----------|-----|-----|-----------------|----------------|--------|---------|-------------------|-----|
| MHK-A40-50 | HSK-A40 | 50 | 40 | 100 | 25 | M6x30 | 55~85 | 10 | 1.7 |
| MHK-A63-70 | HSK-A63 | 70 | 63 | 125 | 30 | M8x35 | 80~100 | 20 | 3.8 |
| MHK-A100-110 | HSK-A100 | 110 | 100 | 200 | 50 | M12x50 | 125~160 | 30 | 14 |

Option

- Mounting plate

Standard Accessories

- T-handle wrench
- Mounting bolt×4pcs.

Note

- The manual clamping hole on the work holder is required for mounting.
- When you can't install it directly on the machine table, please use the mounting plate.
- Contact us about the custom-made mounting plate for your machine table.

Mounting Plate

In the case where you can't mount the head directly to your machine table, please use this mounting plate. We can supply a blank that is customisable and also manufacture a special mounting plate just for you. For more information, please feel free to contact us.

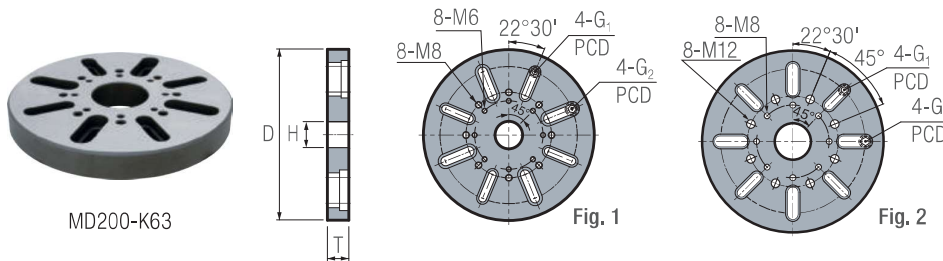

| Part No. | HSK Type | Fig. | T | ØD | ØH | G ₁ | G ₂ | PCD | Kg |
|------------|----------|------|----|-----|----|----------------|----------------|---------|-----|
| MD160-K40 | HSK-A40 | 1 | 20 | 160 | 32 | M5x20 | M6x20 | 80~125 | 2.6 |
| MD200-K40 | | 1 | 25 | 200 | 32 | M8x25 | M10x25 | 100~160 | 5 |
| MD160-K63 | HSK-A63 | 1 | 20 | 160 | 50 | M5x20 | M6x20 | 80~125 | 2.4 |
| MD200-K63 | | 1 | 25 | 200 | 50 | M8x25 | M10x25 | 100~160 | 4.7 |
| MD250-K63 | HSK-A100 | 2 | 30 | 250 | 50 | M10x30 | M12x30 | 140~200 | 9.4 |
| MD250-K100 | | 2 | 30 | 250 | 80 | M10x30 | M12x30 | 140~200 | 8.7 |