

BC01

H-SECTION

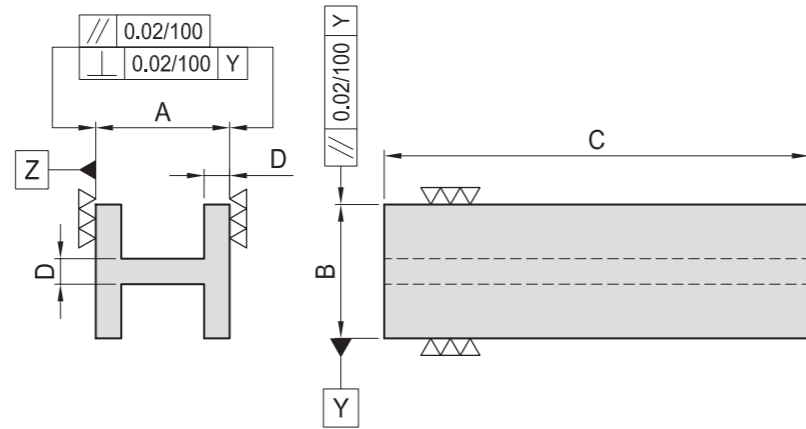
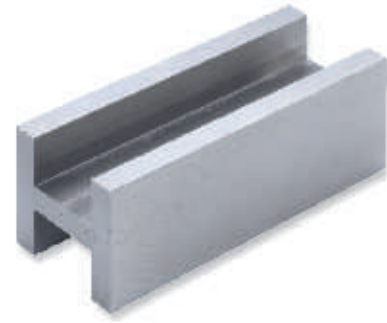

- Material : Cast Iron.
FC-300 (JIS)
GG-30 (DIN)
- Heat treated : Normalized

MODEL NO.	A	B	C	D	E	kg
BC01-063063-200	63	63	200	12	25.5	2.8
BC01-080080-200	80	80	200	16	32.0	4.8
BC01-080080-400			400			9.6
BC01-125125-200	125	125	200	20	52.5	9.6
BC01-125125-400			400			19.3

BC03

RECTANGULAR HOLLOW BLOCK

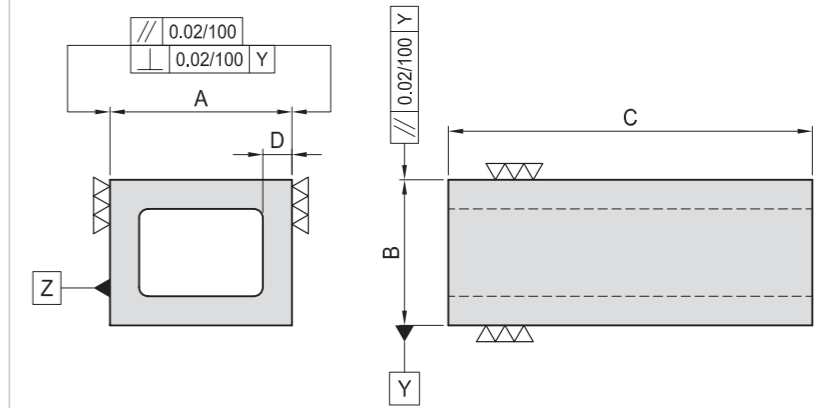

- Material : Cast Iron.
FC-300 (JIS)
GG-30 (DIN)
- Heat treated : Normalized

MODEL NO.	A	B	C	D	kg
BC03-080100-200	100	80	200	16	7.0
BC03-080100-400			400		14.0
BC03-100160-200	160	100	200	18	11.6
BC03-100160-400			400		23.2

BC02

SQUARE HOLLOW BLOCK

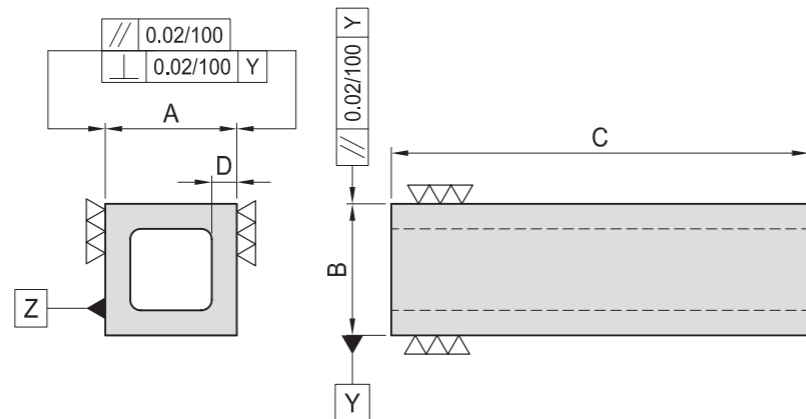

- Material : Cast Iron.
FC-300 (JIS)
GG-30 (DIN)
- Heat treated : Normalized

MODEL NO.	A	B	C	D	kg
BC02-063063-200	63	63	200	12	2.3
BC02-100100-200	100	100	200	16	8.0
BC02-100100-400			400		16.0
BC02-160160-200	160	160	200	20	16.5
BC02-160160-400			400		33.0

BC04

CHANNEL SECTION

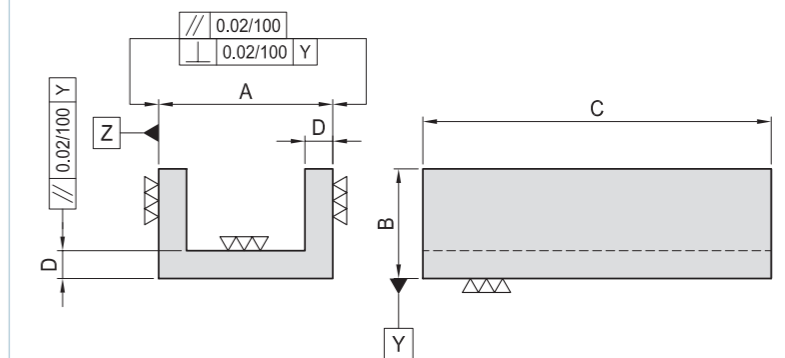

- Material : Cast Iron.
FC-300 (JIS)
GG-30 (DIN)
- Heat treated : Normalized

MODEL NO.	A	B	C	D	kg
BC04-063100-200	100	63	200	16	4.5
BC04-063100-300	100	63	300	16	6.8
BC04-090160-300	160	90	300	20	13.0

BP

BPA

BC

CP

SU

PT

SVF

ALV

OK-
VISE

JER-
GENS

OTHER

Column
for
Technical
Data

BC05

U-SECTION

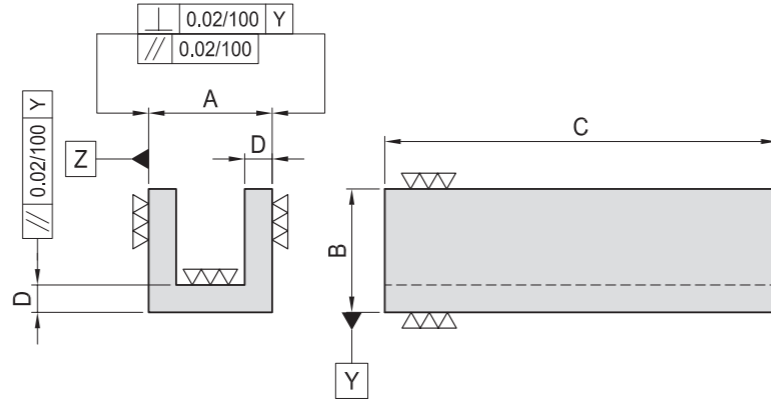
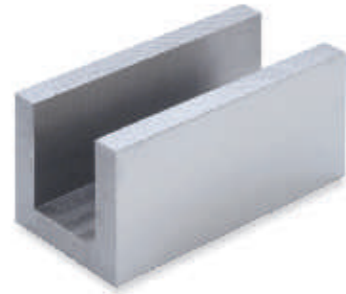

- Material : Cast Iron.
FC-300 (JIS)
GG-30 (DIN)
- Heat treated : Normalized

MODEL NO.	A	B	C	D	kg
BC05-063063-200	63	63	200	14	3.2
BC05-063063-400			400		6.5
BC05-100100-200	100	100	200	20	7.7
BC05-100100-400			400		14.8
BC05-150150-200	150	150	200	25	14.0
BC05-150150-400			400		29.0

BC07

L-SECTION

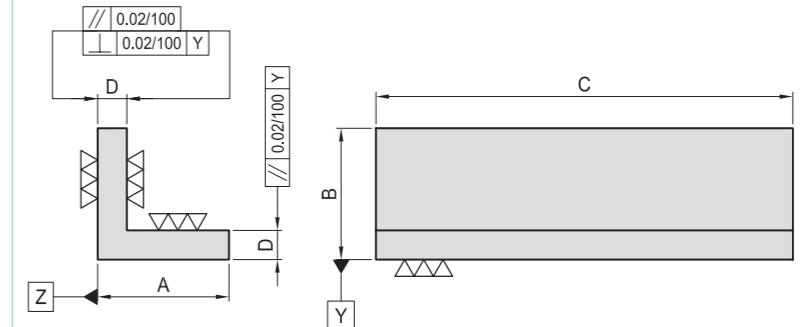

- Material : Cast Iron.
FC-300 (JIS)
GG-30 (DIN)
- Heat treated : Normalized

MODEL NO.	A	B	C	D	kg
BC07-063063-200	63	63	200	14	2.3
BC07-063063-400			400		4.5
BC07-100100-200	100	100	200	20	5.2
BC07-100100-400			400		10.4

BC06

HEAVY DUTY L-SECTION

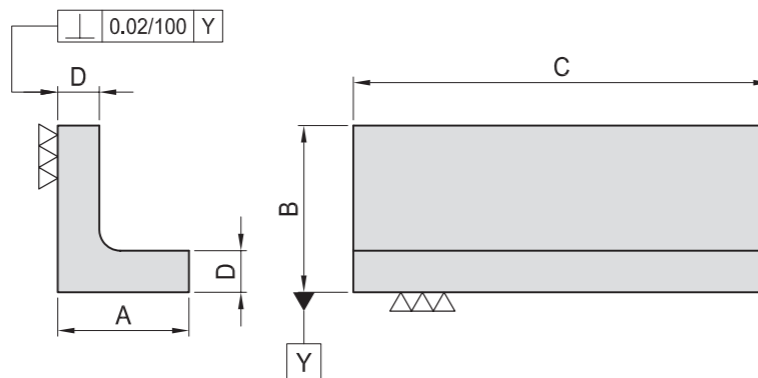
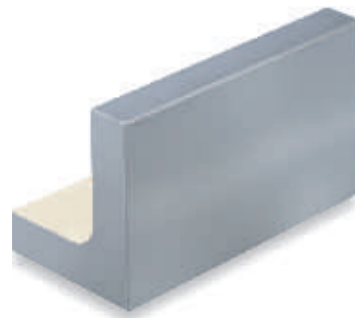

- Material : Cast Iron.
FC-300 (JIS)
GG-30 (DIN)
- Heat treated : Normalized

MODEL NO.	A	B	C	D	kg
BC06-080063-200	63	80	200	20	3.6
BC06-080063-400			400		7.2
BC06-125100-200	100	125	200	25	7.3
BC06-125100-400			400		15.0
BC06-200160-200	160	200	200	32	15.0
BC06-200160-400			400		31.0

BC08

WEBBED L-SECTION

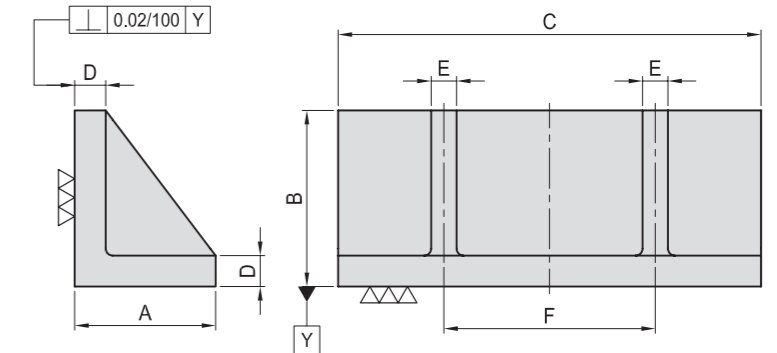

- Material : Cast Iron.
FC-300 (JIS)
GG-30 (DIN)
- Heat treated : Normalized

MODEL NO.	A	B	C	D	E	F	kg
BC08-125100-150	100	125	150	22	18	-	5.3
BC08-125100-300	100	125	300	22	18	150	11.0

BP

BPA

BC

CP

SU

PT

SVF

ALV

OK-
VISE

JER-
GENS

OTHER

Column
for
Technical
Data

BC09

WEBBED T-SECTION

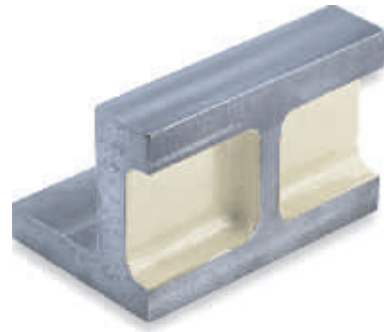

- Material : Cast Iron.
FC-300 (JIS)
GG-30 (DIN)
- Heat treated : Normalized

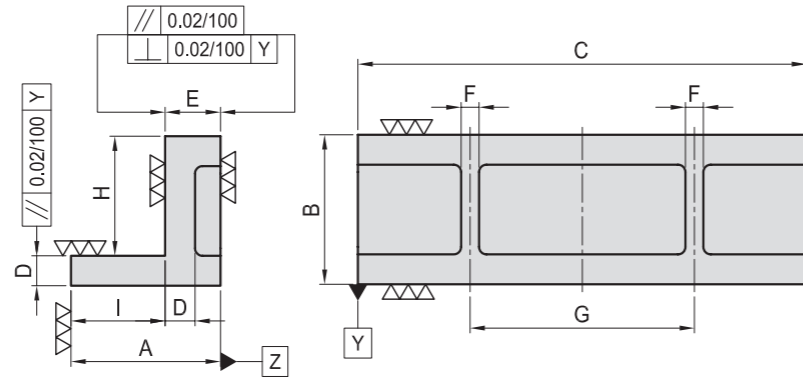

MODEL NO.	A	B	C	D	E	F	G	H	I	kg
BC09-100100-150	100	100	150	20	37	12	-	80	63	4.4
BC09-100100-300	100	100	300	20	37	12	150	80	63	8.7

BC12

UNEQUAL L-SECTION



- Material : Cast Iron.
FC-300 (JIS)
GG-30 (DIN)
- Heat treated : Normalized

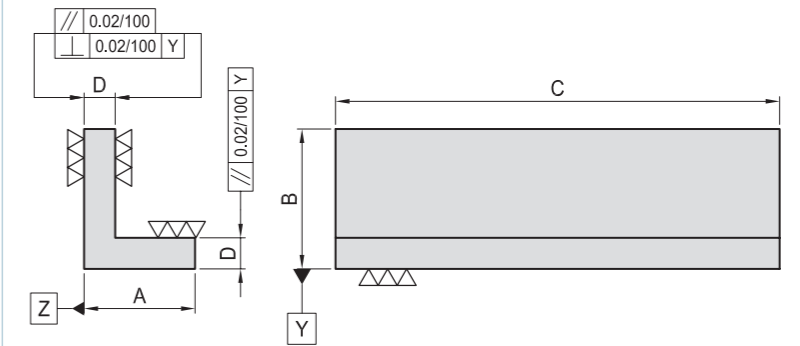

MODEL NO.	A	B	C	D	kg
BC12-063050-200	50	63	200	14	2.0
BC12-063050-300	50	63	300	14	3.0
BC12-063050-500	50	63	500	14	5.0

BC10

STEEL RECTANGULAR PLATE

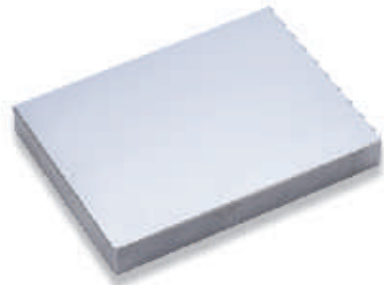

- Material : Cast Iron.
FC-300 (JIS)
GG-30 (DIN)
- Heat treated : Normalized

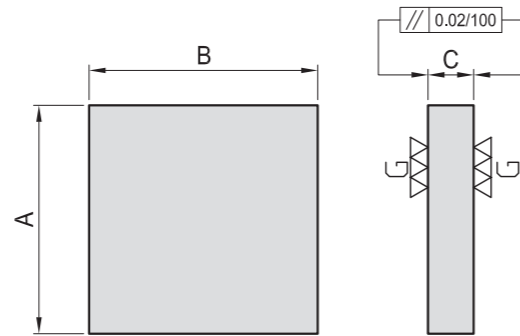

MODEL NO.	A	B	C	kg
BC10-20100-100	100	100	20	1.6
BC10-20100-150		150		2.3
BC10-25150-200	150	200	25	5.9
BC10-25150-250		250		7.3
BC10-25200-200	200	200	25	7.8
BC10-25200-250		250		9.8
BC10-25250-250	250	250	25	12.0

BC13

ANGULAR HOLLOW BLOCK 45°

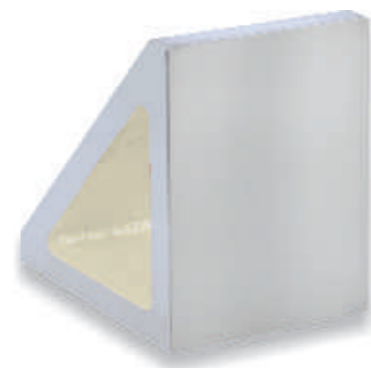

- Material : Cast Iron.
FC-300 (JIS)
GG-30 (DIN)
- Heat treated : Normalized

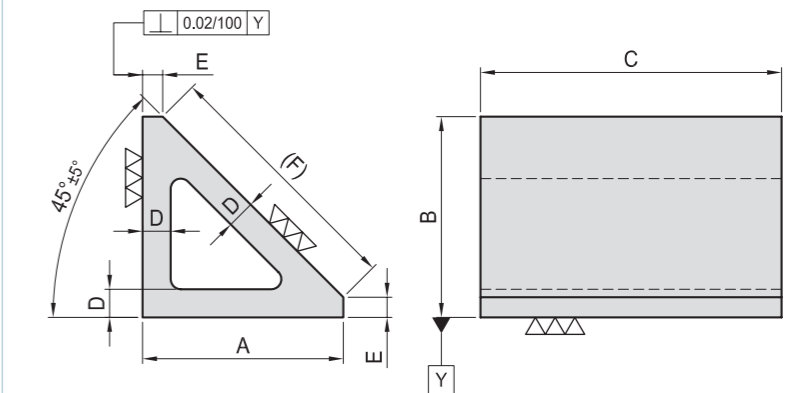

MODEL NO.	A	B	C	D	E	F	kg
BC13-100100-150	100	100	150	14	10	127	4.5
BC13-100100-300			300				8.8
BC13-200200-150	200	200	150	22	20	255	15.0
BC13-200200-300			300				29.0

BP

BPA

BC

CP

SU

PT

SVF

ALV

OK-
VISE

JER-
GENS

OTHER

Column
for
Technical
Data

BC14

ANGULAR HOLLOW BLOCK 30°

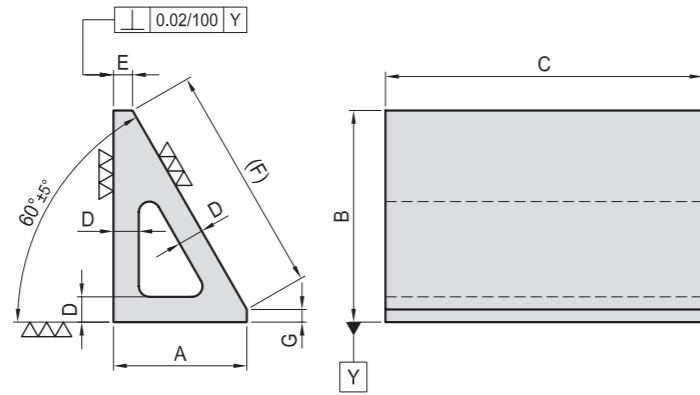

- Material : Cast Iron.
FC-300 (JIS)
GG-30 (DIN)
- Heat treated : Normalized

MODEL NO.	A	B	C	D	E	F	G	kg
BC14-100063-150	63	100	150	12	9	108	6	3.0
BC14-100063-300			300					6.0
BC14-200125-150	125	200	150	20	14	222	8	9.5
BC14-200125-300			300					19.0