

Locating Rails for Jigs and Fixtures

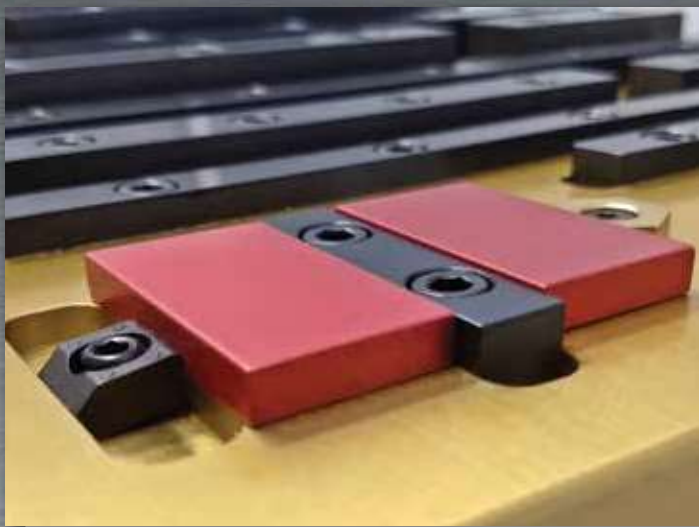

Locating rails are made of low carbon steel and are precision ground square. They are available in a number of sizes and lengths to suit most applications.



Locating rails used with Machinable Uniforce® and Pitbull® Clamps

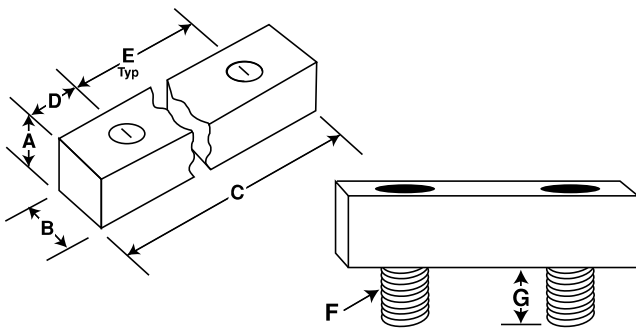

	Part Number	A	B +/- .0005	C	D	E	F	G	No. Holes
INCH	33110	.35	.480	.750	.NA	.NA	1/4-20	.38	1
	33120	.35	.480	2.00	.50	1.00	1/4-20	.38	2
	33140	.35	.480	4.00	1.00	1.00	1/4-20	.38	3
	33160	.35	.480	6.00	.75	1.50	1/4-20	.38	4
	33180	.35	.480	10.00	1.00	2.00	1/4-20	.38	5
	33200	.48	.730	3.00	.75	1.50	1/4-20	.38	2
	33220	.48	.730	6.00	.75	1.50	1/4-20	.38	4
	33240	.48	.730	10.00	1.00	2.00	1/4-20	.38	5
	33260	.73	.980	3.00	.75	1.50	3/8-16	.62	2
	33280	.73	.980	6.00	1.00	2.00	3/8-16	.62	3
	33300	.73	.980	10.00	1.00	2.00	3/8-16	.62	5
	33320	.98	1.230	6.00	1.00	2.00	1/2-13	.75	3
	33340	.98	1.230	10.00	1.25	2.50	1/2-13	.75	4
	33360	1.48	1.980	6.00	1.00	2.00	1/2-13	.75	3
33380	1.48	1.980	10.00	1.25	2.50	1/2-13	.75	4	

Mounting Screws included.

Is it taking too long to make a fixture to increase production?

Mitee-Bite Products makes fixture building easier and quicker with the addition of ready made locating rails.

Rails are made of low carbon steel, then ground square. They are easily machined when used with our machinable clamps. Tungsten Carbide coating can be added to increase holding force.

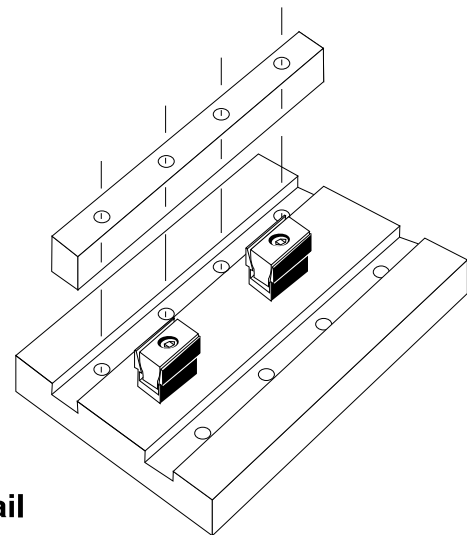

Locating Rail Installation:

1. Mill a slot to locate the rail.
Depth of the slot will determine rail height.
2. Drill and tap the required holes to mount the rail.
3. For better rigidity, the rail should be pinned to the fixture plate with dowel pins.
4. If rails are to be machined to hold round pieces, the clamps should be mounted and both rail and clamp machined at the same time.

	Part Number	A	B + .000 - .013	C	D	E	F	G	No. Holes
METRIC	83200	12	15	50	15	20	M6	11mm	2
	83210	12	15	100	20	30	M6	11mm	3
	83220	12	15	150	30	30	M6	11mm	4
	83240	12	15	250	25	50	M6	11mm	5
	83260	18	24	75	20	35	M10	18mm	2
	83280	18	24	150	30	30	M10	18mm	4
	83300	18	24	250	25	50	M10	18mm	5