

TOE CLAMP RAIL FOR USE WITH CHICK TOE CLAMPS ORDER NUMBER 005-0254

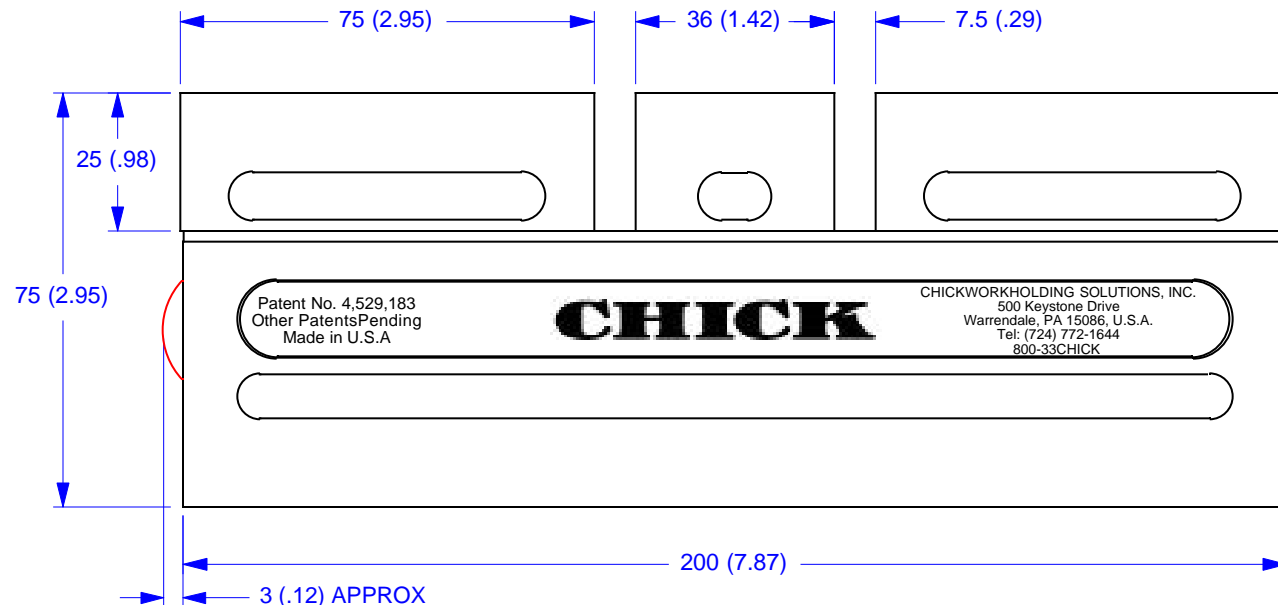

Patent No. 4,529,183
Other Patents Pending
Made in U.S.A

CHICK

CHICKWORKHOLDING SOLUTIONS, INC.
500 Keystone Drive
Warrendale, PA 15086, U.S.A.
Tel: (724) 772-1644
800-33CHICK

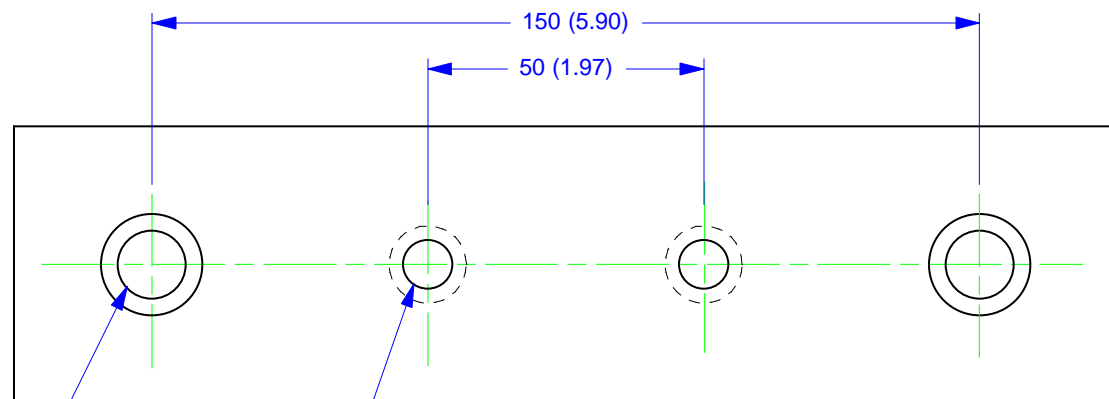

LOCATING HOLES
Ø 12.007 (.4727) X 15 (.039) DP
2 PLACES

MOUNTING HOLES FOR
M8 SOCKET-HEAD CAP
SCREWS
2 PLACES

NOTES:

- DIMENSIONS INCLUDE STANDARD DUAL STATION MACHINABLE JAWS SET(S)
- DIMENSIONS ARE IN mm(IN)
- SYSTEM WEIGHT 2kg (5lbs)

CHICK 500 Keystone Drive
Warrendale, PA USA
(800) 33-CHICK • (724) 772-1644
www.chick-workholding.com

SYSTEM 5
0520 QWIK-LOK

JKS 1 OF 1
17 NOV 97

081-1200