

TOE CLAMP RAIL FOR USE WITH
CHICK TOE CLAMPS
ORDER NUMBER 005-0254

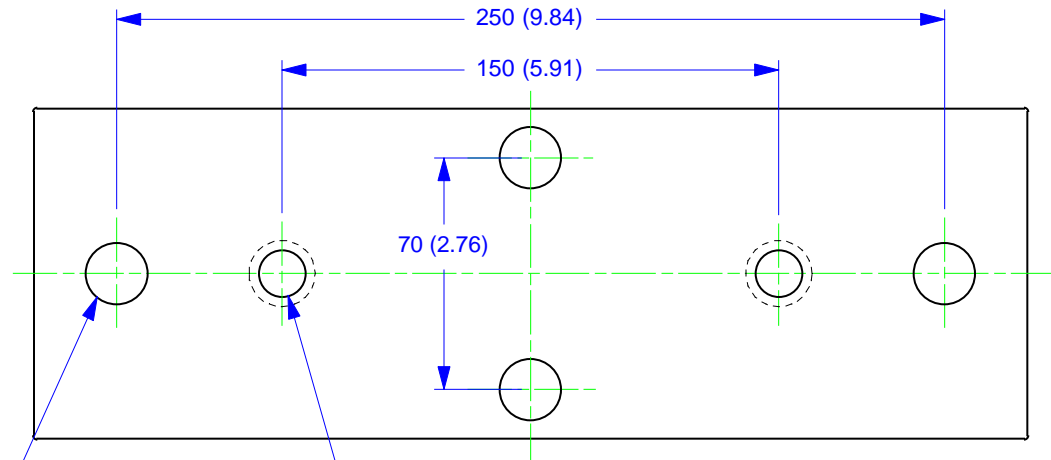
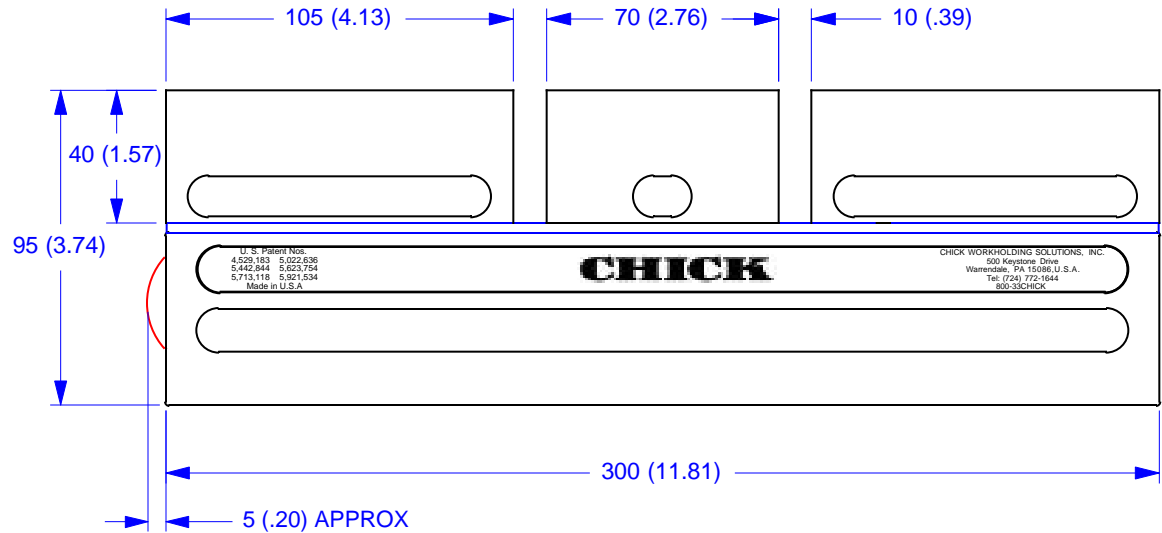

LOCATING HOLES
Ø 12.007 ±0.007 (.4727)X 15 (.039)DP
4 PLACES

MOUNTING HOLES FOR
M12 SOCKET-HEAD CAP
SCREWS
2 PLACES

NOTES:

- DIMENSIONS INCLUDE STANDARD DUAL STATION MACHINABLE JAWS SET(S)
- DIMENSIONS ARE IN mm(IN)
- SYSTEM WEIGHT 9kg (19lbs)

CHICK 500 Keystone Drive
Warrendale, PA USA
(800) 33-CHICK • (724) 772-1644
www.chick-workholding.com

SYSTEM 5
1030 QWIK-LOK

GS	1 OF 1	5QL1030
22 AUG 02		