

TOE CLAMP RAIL FOR USE WITH  
CHICK TOE CLAMPS  
ORDER NUMBER 005-0254

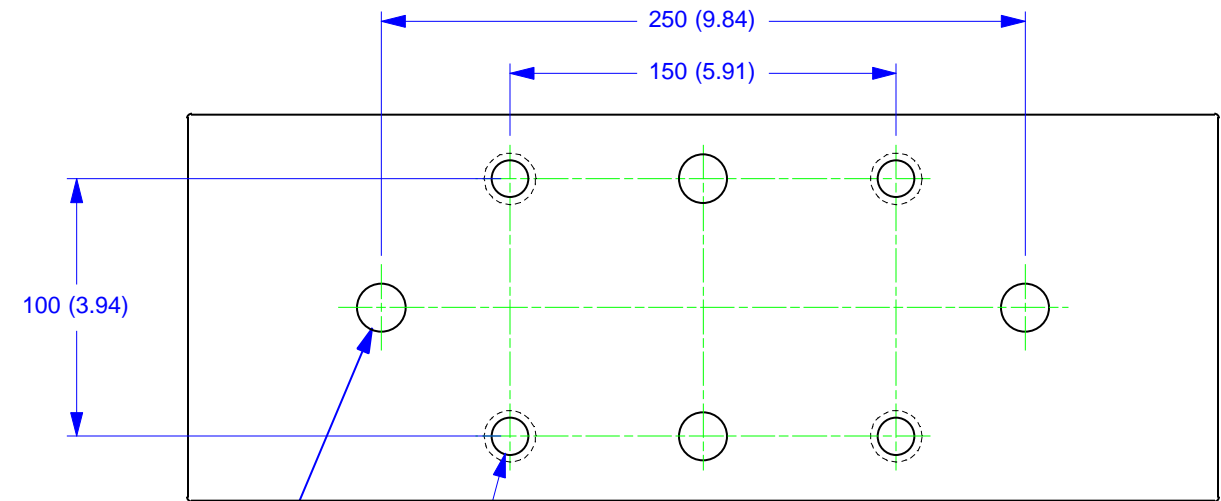
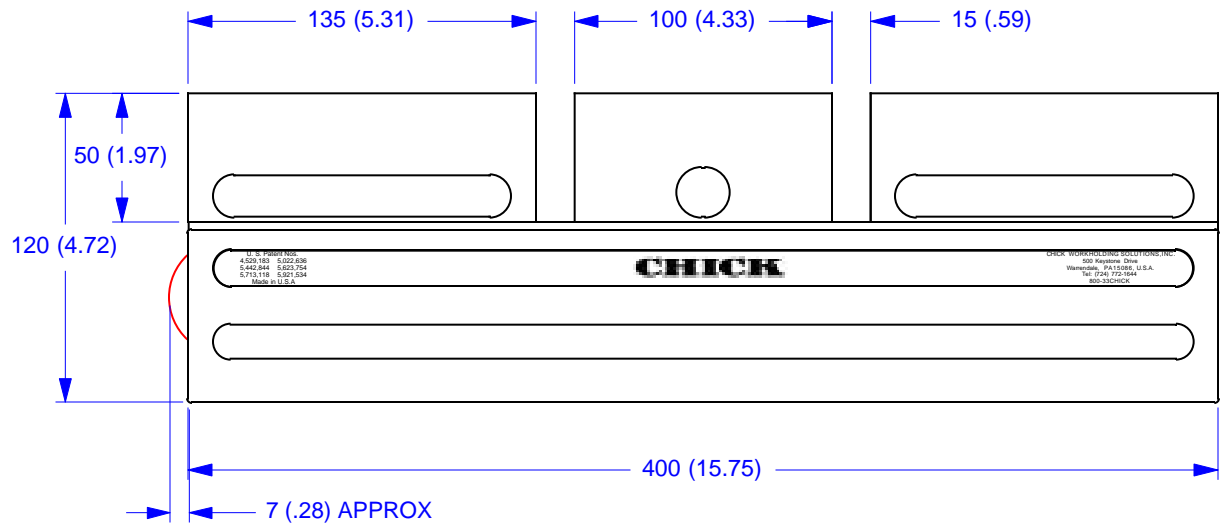

LOCATING HOLES  
Ø 12.007 (.4727)X 15 (.039)DP  
2 PLACES

MOUNTING HOLES FOR  
M12 SOCKET-HEAD CAP  
SCREWS  
4 PLACES

- NOTES:
- DIMENSIONS INCLUDE STANDARD DUAL STATION MACHINABLE JAWS SET(S)
  - DIMENSIONS ARE IN mm(IN)
  - SYSTEM WEIGHT 21kg (46lbs)

**CHICK** 500 Keystone Drive  
Warrendale, PA USA  
(800) 33-CHICK • (724) 772-1644  
www.chick-workholding.com

SYSTEM 5  
1540 QWIK-LOK

GS	1 OF 1	5QL1540
22 AUG 02		