

NOTES: Unless otherwise specified.

1. Machined surfaces  $\perp$  .001 in 12" // .002 in 12"  $\square$  .001 in 12"
2. Deburr and break all sharp edges.

THE INFORMATION CONTAINED IN THIS DRAWING IS THE SOLE PROPERTY OF ABBOTT WORKHOLDING PRODUCTS. ANY REPRODUCTION IN PART OR WHOLE WITHOUT THE WRITTEN PERMISSION OF ABBOTT WORKHOLDING PRODUCTS IS PROHIBITED.

**Includes 1/4" Top Plate And (2) Lifting Rings**

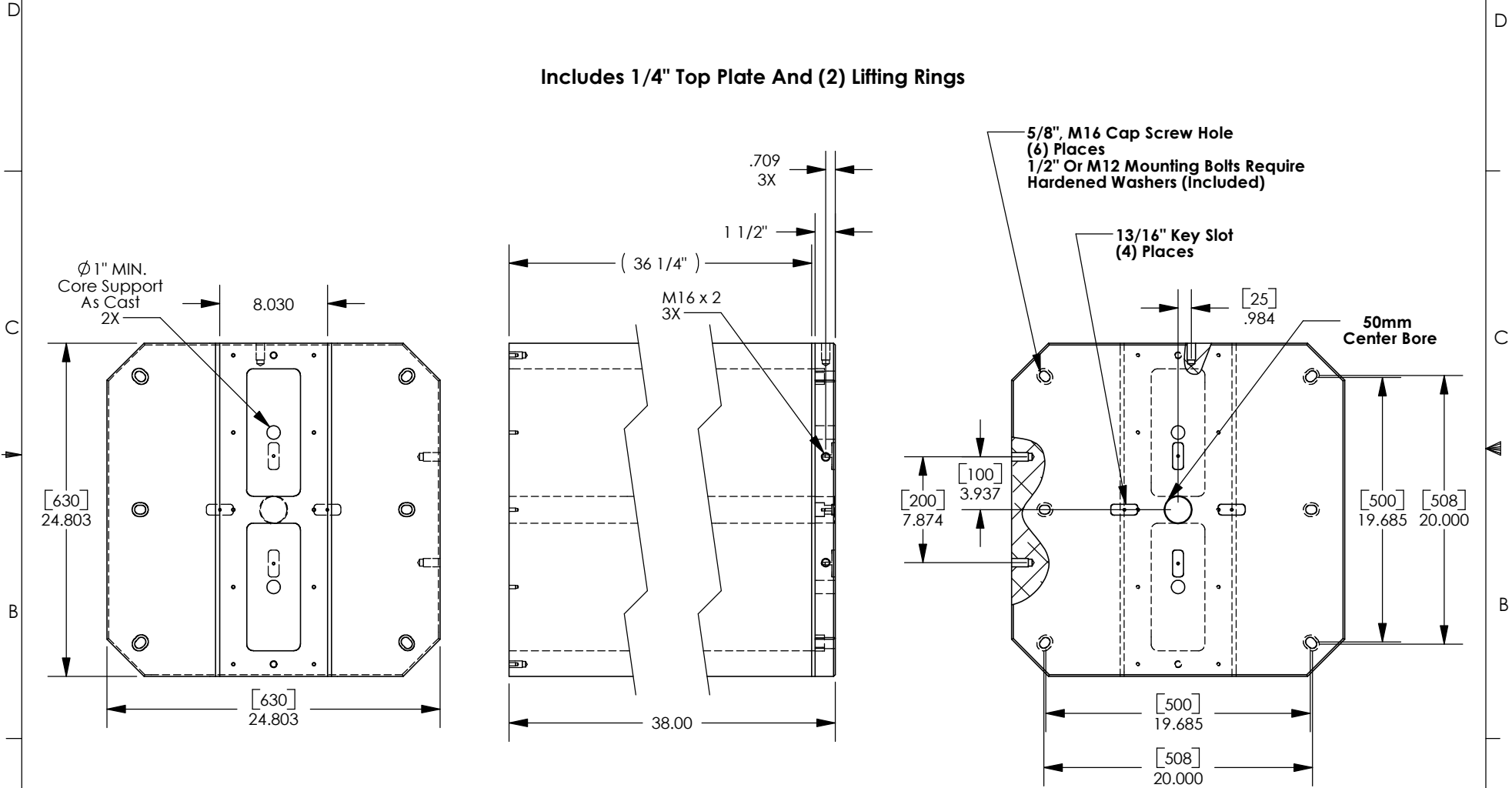

UNLESS OTHERWISE SPECIFIED DIMENSIONS ARE IN INCHES TOLERANCES ARE: FRACTIONS DECIMALS ANGLES $\pm 1/32$ .XX $\pm$ .015 $\pm 5^\circ$ .XXX $\pm$ .005 .XXXX $\pm$ .0005		<b>Abbott Workholding Products</b> 430 McCall Road Manhattan, KS 66502 785-776-8555 785-587-0004 Fax 800-528-6459 www.abbottworkholding.com engineering@abbottworkholding.com	
DRAWN TBJ	DATE 09/21/15	SIZE A	Part Name D82538-630UM
MATERIAL 713	WEIGHT (POUNDS) 550.7	CUSTOMER: Stock	REV. C
STYLE TC	DISPOSITION Released		