

仕様 SPECIFICATIONS	
割出精度 INDEXING ACCURACY	20 sec以内
再現精度 REPEATABILITY	4 sec以内
テーブル最高回転速度 MAXIMUM ROTATION SPEED	44.4 min ⁻¹ [モータ 2000 min ⁻¹]
フランジトルク CLAMPING TORQUE	2100N·m [圧力 3.5MPa]
許容最大油圧力 MAXIMUM HYD. PRESS	3.5 MPa
許容積載質量 ALLOWABLE MASS OF WORK	450 kg
許容積載ワーク径 ALLOWABLE WORK DIA.	φ350 mm
総減速比 TOTAL REDUCTION RATIO	1/45
製品質量 MASS OF ROTARY TABLE	200 kg
駆動系モーメント慣性 MACHINE INERTIA (REDUCED TO MOTOR SHAFT)	

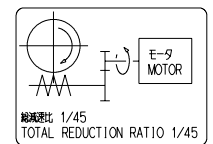
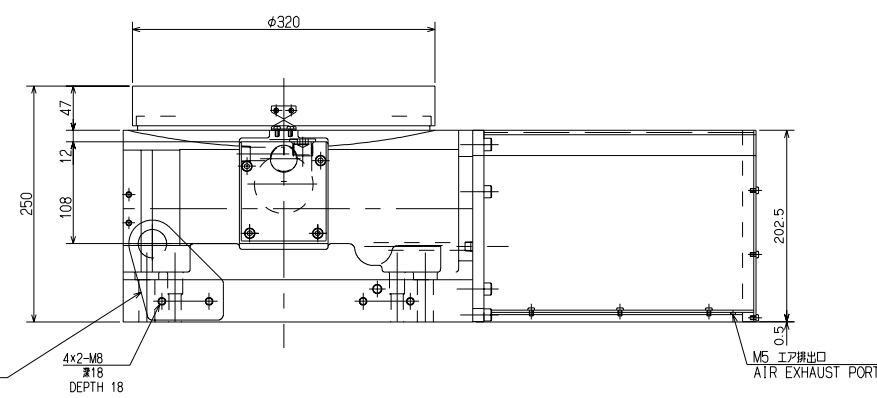
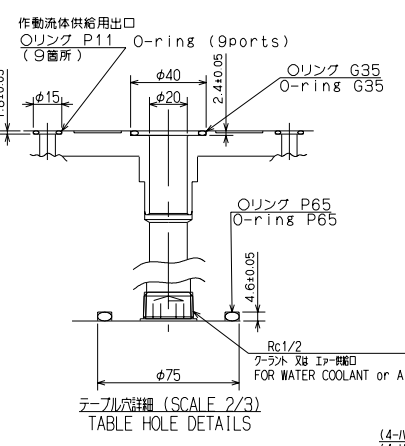
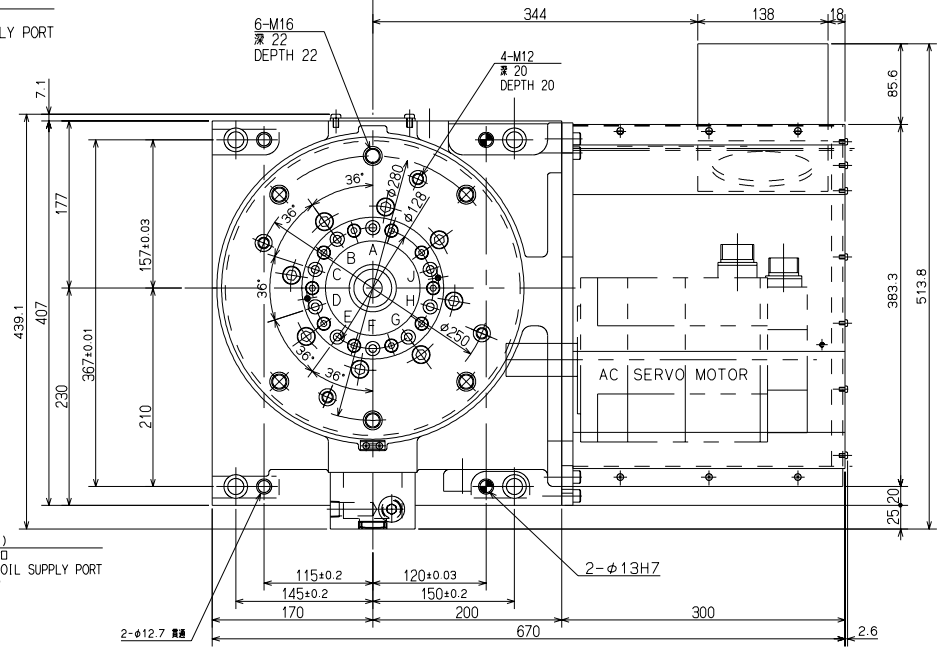
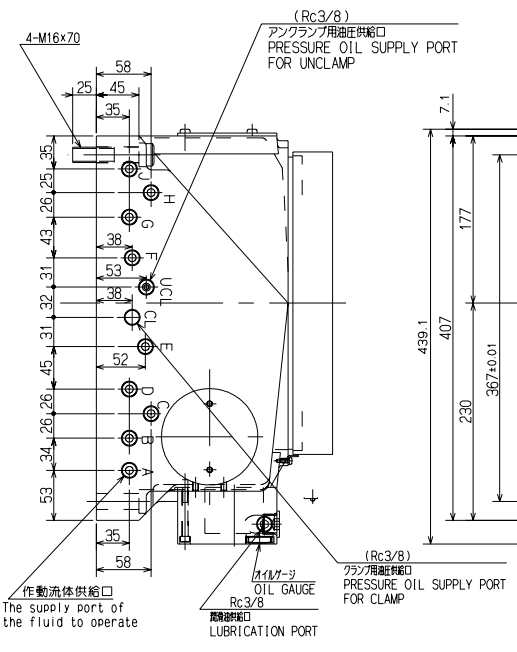

駆動系スケルトン
SKELTON DRAWING
OF DRIVE SYSTEM

CAREER	SCALE	TYPE	LR320HF01	WEIGHT	k.g
MANAGER	CHIEF	DRAWN BY	NCテーブル NC ROTARY TABLE		
			NAME	LR320HF01 ガイエイ	OUTSIDE VIEW
			3RD ANGLE		
KITAGAWA IRON WORKS CO., LTD.	DATE	DRW NO.	61E 24 2898		