

SECTION A-A

MATERIAL:	NA
HARDNESS:	NA
COATING:	NA
WEIGHT:	82685 g
COMMENTS:	

UNSPECIFIED TOLERANCES:	
X	±0.2
X.X	±0.1
X.XX	±0.05
ANGLES	±0.5°
ALL DIMENSIONS ARE MILLIMETERS.	

 (800) 332-4425
 (724) 772-1644
www.ChickWorkholding.com

UNSPECIFIED EDGES: BREAK 0.3 TO 0.8
 UNSPECIFIED FILLETS: RADIUS 0.3 MAX

ITEM: WORK PKG - 5-AXIS			
TYPE: DECKEL MAHO DMC 80U (M16 TAPPED)			
FAM: 5ML1040-41			
STYLE: 208 SQ BASE X 550 TALL			
TDD	2 OF 4	5AP-DECK-00122	REV
11/6/2009			A

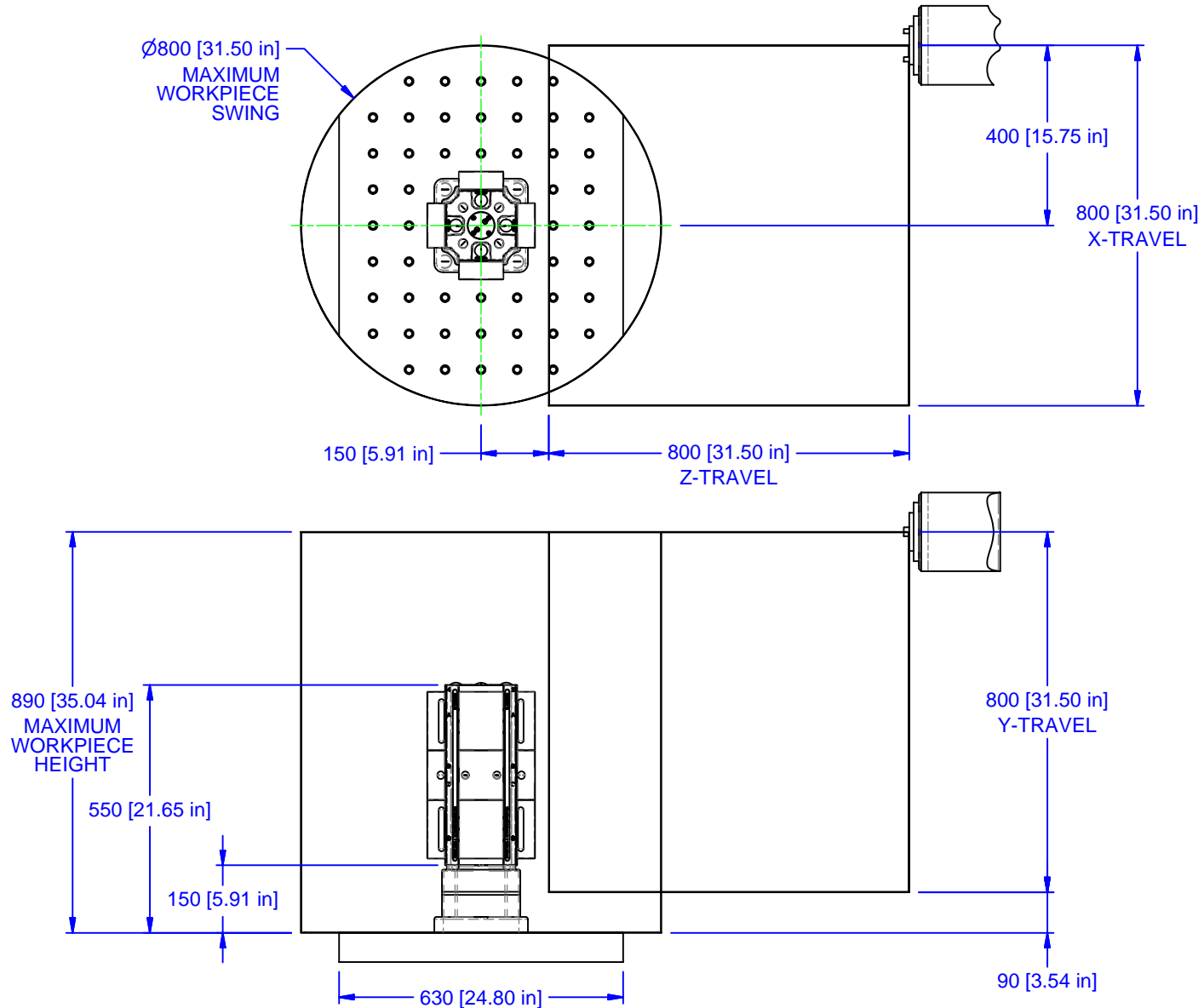

MATERIAL:	NA
HARDNESS:	NA
COATING:	NA
WEIGHT:	82685 g
COMMENTS:	

UNSPECIFIED TOLERANCES:	
X	±0.2
X.X	±0.1
X.XX	±0.05
ANGLES	±0.5°
ALL DIMENSIONS ARE MILLIMETERS.	

 (800) 332-4425
 (724) 772-1644
www.ChickWorkholding.com

UNSPECIFIED EDGES: BREAK 0.3 TO 0.8
 UNSPECIFIED FILLETS: RADIUS 0.3 MAX

ITEM: WORK PKG - 5-AXIS			
TYPE: DECKEL MAHO DMC 80U (M16 TAPPED)			
FAM: 5ML1040-41			
STYLE: 208 SQ BASE X 550 TALL			
TDD	3 OF 4	5AP-DECK-00122	REV A
11/6/2009			

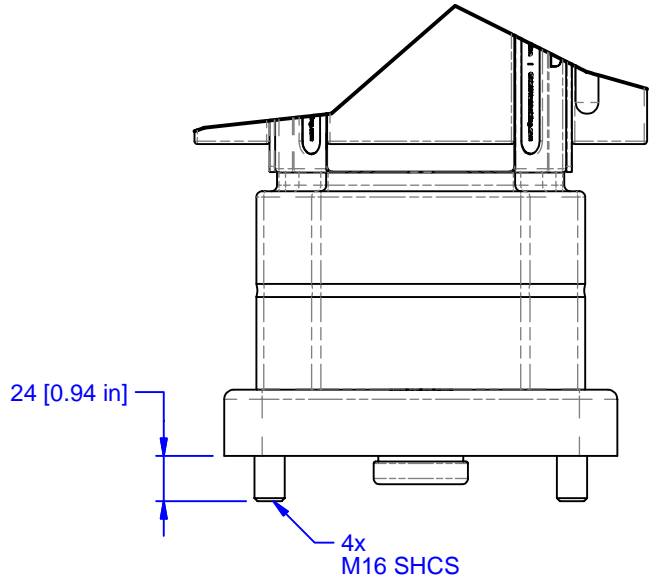
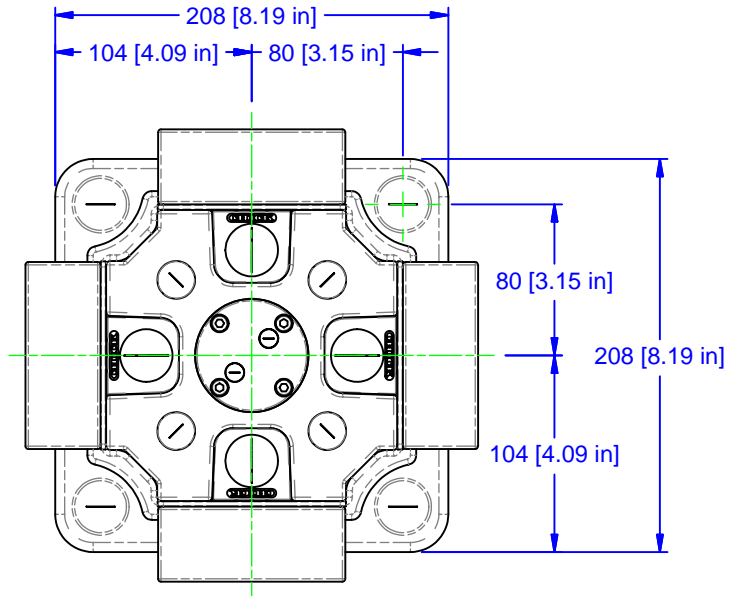
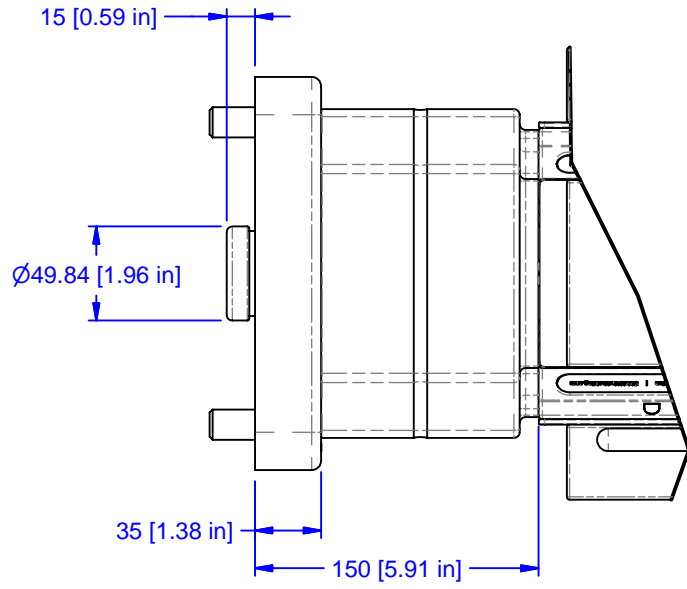

MATERIAL:	NA
HARDNESS:	NA
COATING:	NA
WEIGHT:	82685 g
COMMENTS:	

UNSPECIFIED TOLERANCES:
 X ±0.2
 X.X ±0.1
 X.XX ±0.05
 ANGLES ±0.5°
 ALL DIMENSIONS ARE MILLIMETERS.

CHICK (800) 332-4425
 (724) 772-1644
www.ChickWorkholding.com
 UNSPECIFIED EDGES: BREAK 0.3 TO 0.8
 UNSPECIFIED FILLETS: RADIUS 0.3 MAX

ITEM: WORK PKG - 5-AXIS			
TYPE: DECKEL MAHO DMC 80U (M16 TAPPED)			
FAM: 5ML1040-41			
STYLE: 208 SQ BASE X 550 TALL			
TDD	4 OF 4	5AP-DECK-00122	REV
11/6/2009			A