

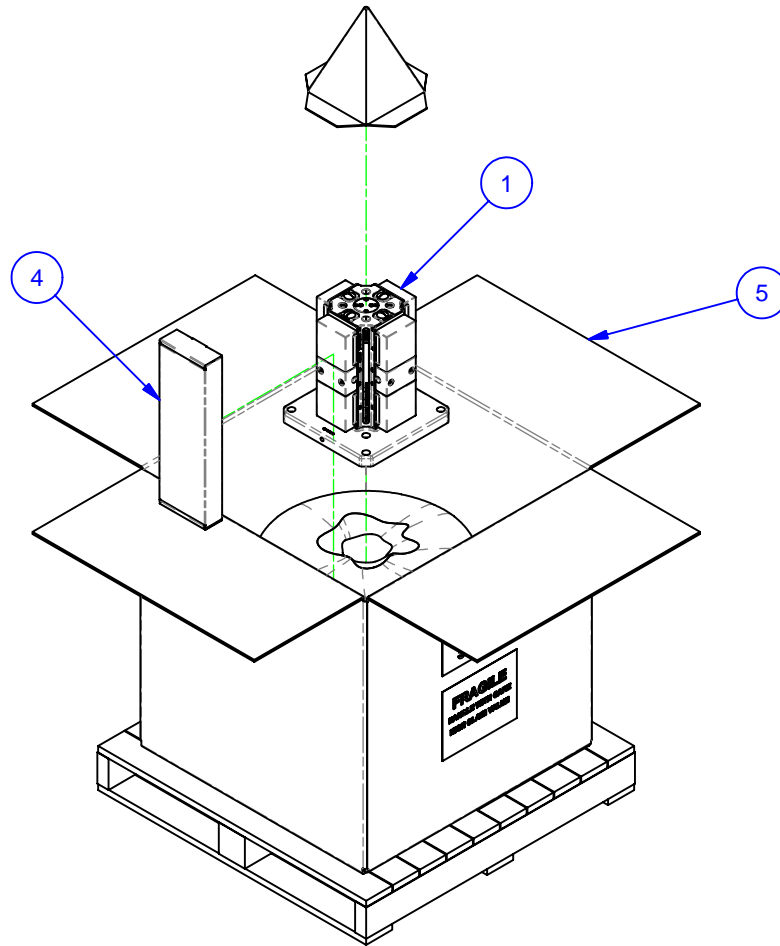

PARTS LIST						
No	QTY	PN	ITEM	TYPE	FAM	STYLE
1	1	188-1-10087	MULTI-LOK ASSEMBLY	MATSUURA MAM72-42V	5ML1030-41	300 SQ BASE X 335 TALL
2	1	058-2-10041	KIT	BASEPLATE MOUNTING	1/2-13 TAPPED HOLE	(8) 1/2-13 X 1.25" SHCS
3	1	058-2-10067	KIT	EDGE LOCATING	1/2-13 TAPPED HOLE	(3) 1/2-13 X 1.25" SHCS
4	1	185-0-10003	KIT	TOOLS	5ML10-41	STANDARD
5	1	185-0-10005	PACKAGING	SHIPPING CONTAINER	HMC WORK PKG.	36x36x30 [M12 W/8" BOLTS]



MATERIAL: NA	UNSPECIFIED TOLERANCES: X ±0.2 X.X ±0.1 X.XX ±0.05 ANGLES ±0.5° ALL DIMENSIONS ARE MILLIMETERS.	 (800) 332-4425 (724) 772-1644 www.ChickWorkholding.com	ITEM: WORK PKG - 5-AXIS	TDD 1 OF 4 REV 8/5/2008 5AP-MATS-00191 A
HARDNESS: NA			TYPE: MATSUURA MAM72-42V_I	
COATING: NA			FAM: 5ML1030-41	
WEIGHT: 67900 g			STYLE: 300 SQ BASE X 335 TALL	
COMMENTS:			UNSPECIFIED EDGES: BREAK 0.3 TO 0.8 UNSPECIFIED FILLETS: RADIUS 0.3 MAX	

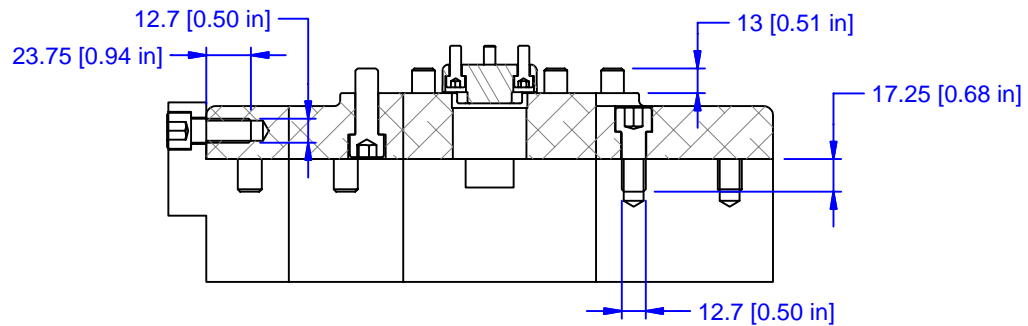
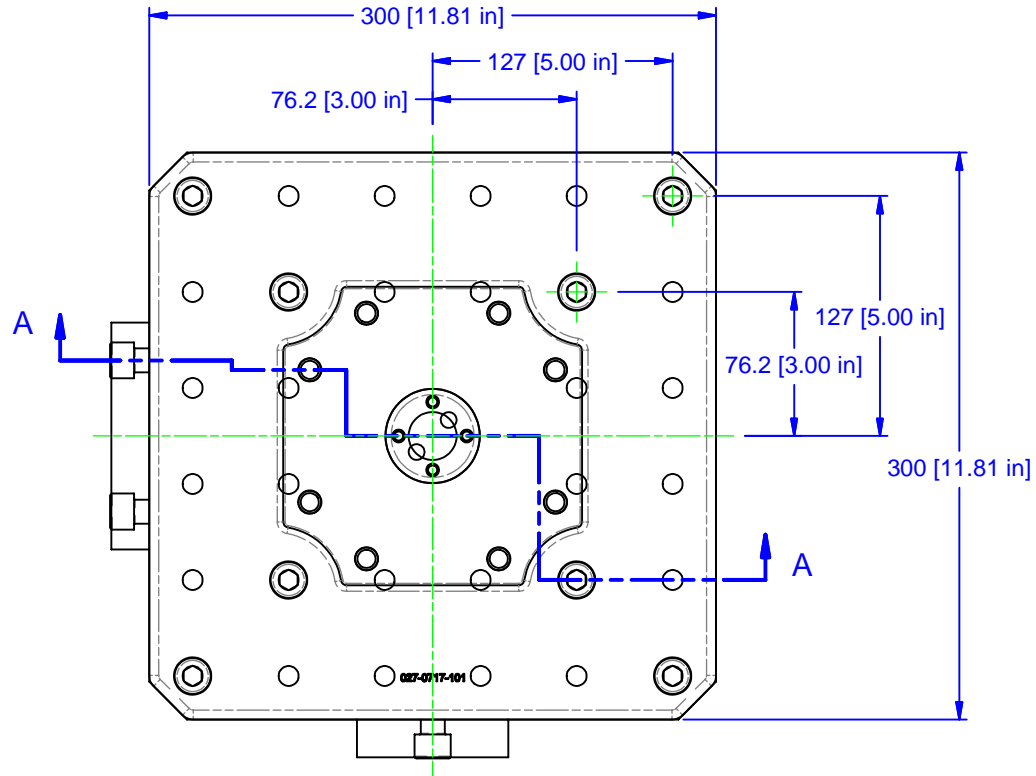

SECTION A-A

MATERIAL:	NA
HARDNESS:	NA
COATING:	NA
WEIGHT:	67900 g
COMMENTS:	

UNSPECIFIED TOLERANCES:

X	±0.2
X.X	±0.1
X.XX	±0.05
ANGLES	±0.5°

ALL DIMENSIONS ARE MILLIMETERS.

CHICK (800) 332-4425
 (724) 772-1644
www.ChickWorkholding.com

UNSPECIFIED EDGES: BREAK 0.3 TO 0.8
 UNSPECIFIED FILLETS: RADIUS 0.3 MAX

ITEM:	WORK PKG - 5-AXIS		
TYPE:	MATSUURA MAM72-42V_I		
FAM:	5ML1030-41		
STYLE:	300 SQ BASE X 335 TALL		
TDD	2 OF 4	5AP-MATS-00191	REV A
8/5/2008			

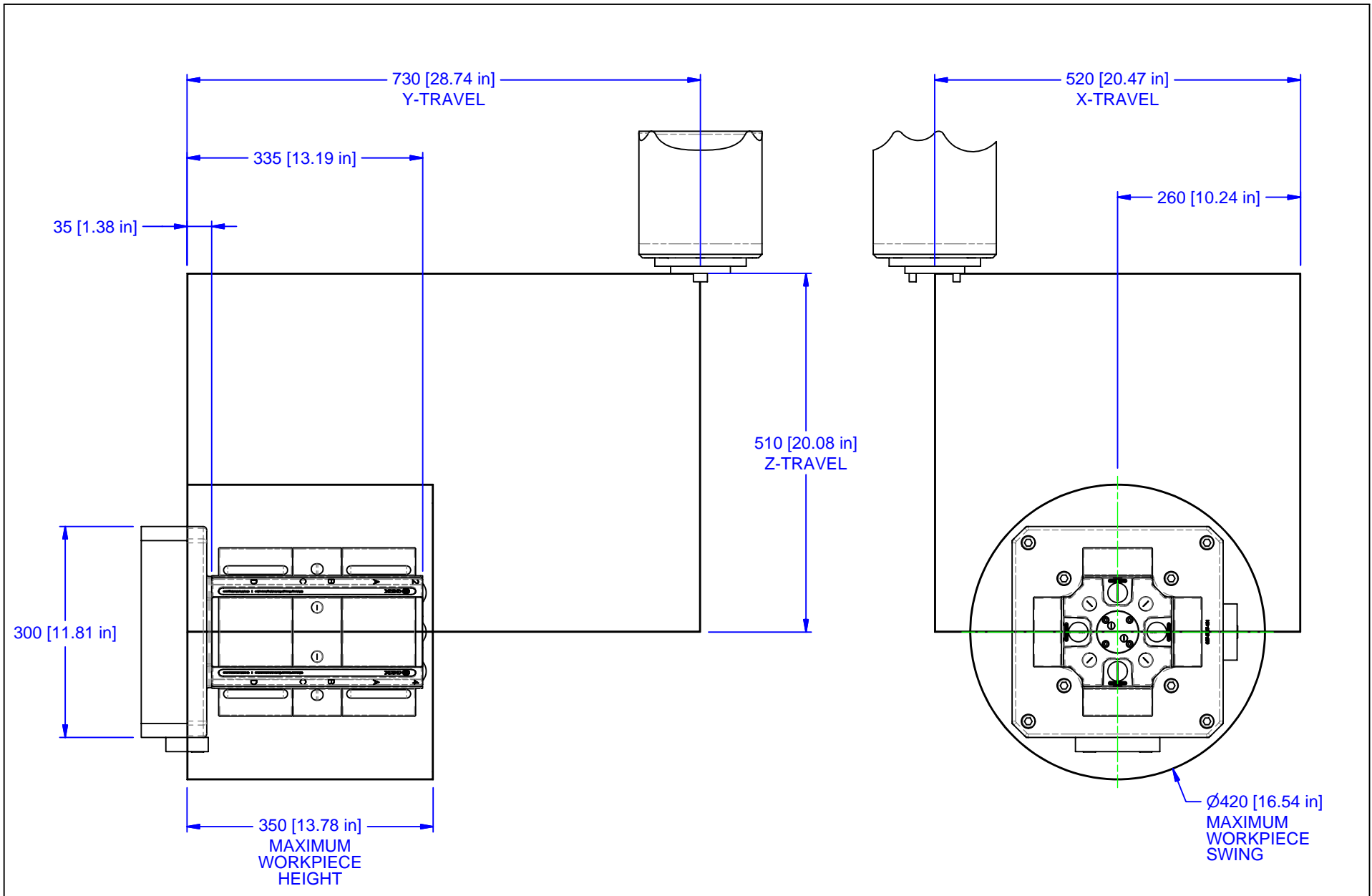

MATERIAL: NA	UNSPECIFIED TOLERANCES: X ±0.2 X.X ±0.1 X.XX ±0.05 ANGLES ±0.5° ALL DIMENSIONS ARE MILLIMETERS.	 (800) 332-4425 (724) 772-1644 www.ChickWorkholding.com	ITEM: WORK PKG - 5-AXIS	<table border="1"> <tr> <td>TDD</td> <td>3 OF 4</td> <td rowspan="2">5AP-MATS-00191</td> <td rowspan="2">REV A</td> </tr> <tr> <td colspan="2">8/5/2008</td> </tr> </table>	TDD	3 OF 4	5AP-MATS-00191	REV A	8/5/2008	
TDD			3 OF 4		5AP-MATS-00191	REV A				
8/5/2008										
HARDNESS: NA			TYPE: MATSUURA MAM72-42V_I							
COATING: NA			FAM: 5ML1030-41							
WEIGHT: 67900 g	STYLE: 300 SQ BASE X 335 TALL									
COMMENTS:	UNSPECIFIED EDGES: BREAK 0.3 TO 0.8 UNSPECIFIED FILLETS: RADIUS 0.3 MAX									

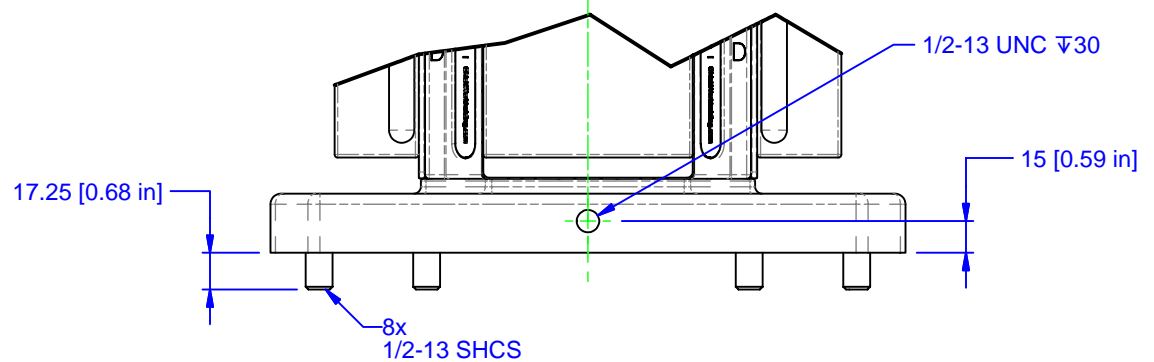
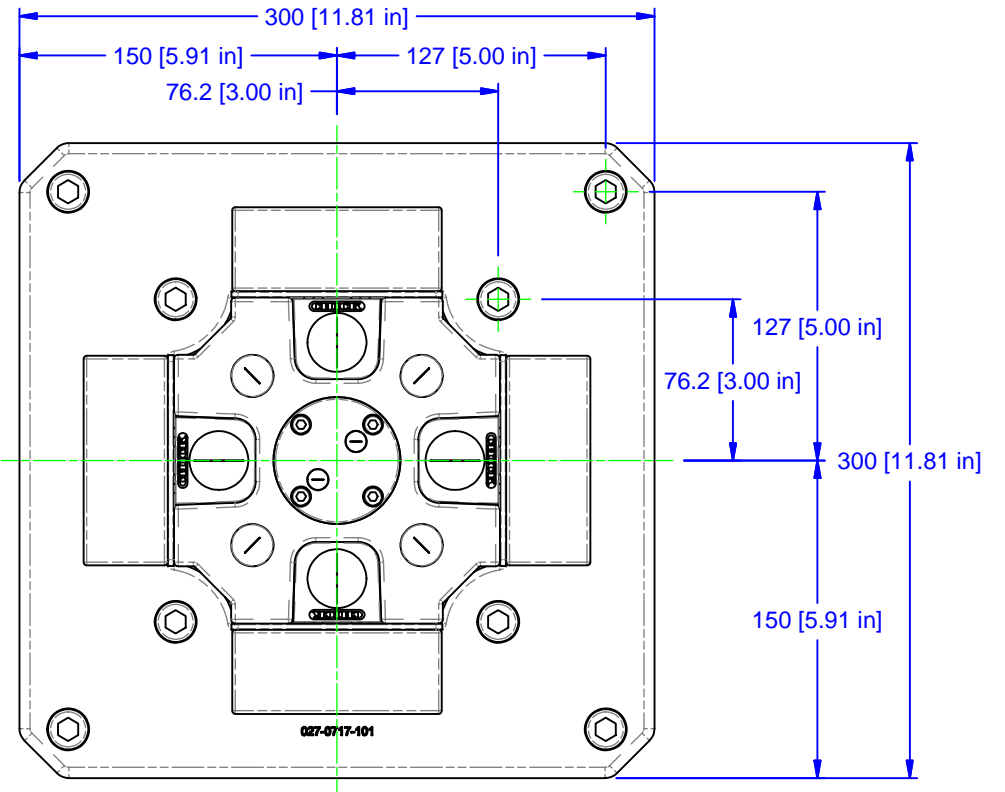
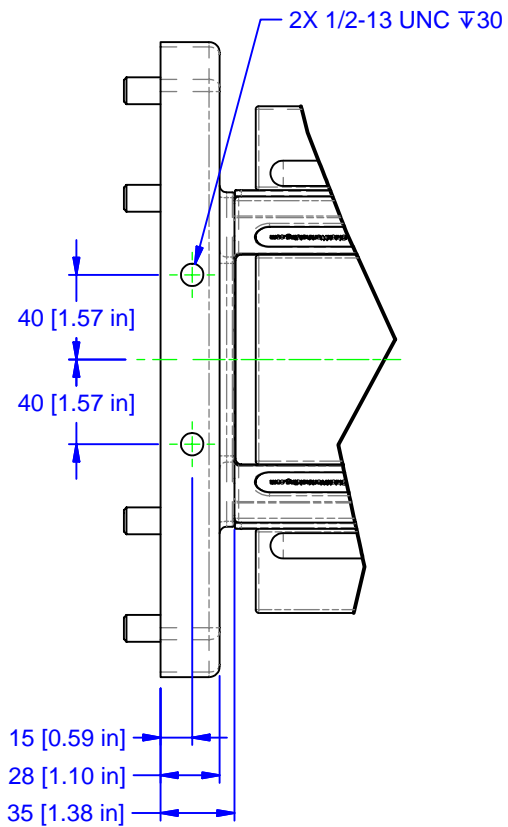

MATERIAL: NA
HARDNESS: NA
COATING: NA
WEIGHT: 67900 g
COMMENTS:

UNSPECIFIED TOLERANCES:	
X	± 0.2
X.X	± 0.1
X.XX	± 0.05
ANGLES	$\pm 0.5^\circ$
ALL DIMENSIONS ARE MILLIMETERS.	

CHICK (800) 332-4425
 (724) 772-1644
www.ChickWorkholding.com

UNSPECIFIED EDGES: BREAK 0.3 TO 0.8
 UNSPECIFIED FILLETS: RADIUS 0.3 MAX

ITEM: WORK PKG - 5-AXIS	
TYPE: MATSUURA MAM72-42V_I	
FAM: 5ML1030-41	
STYLE: 300 SQ BASE X 335 TALL	
TDD	4 OF 4
8/5/2008	5AP-MATS-00191
REV	A