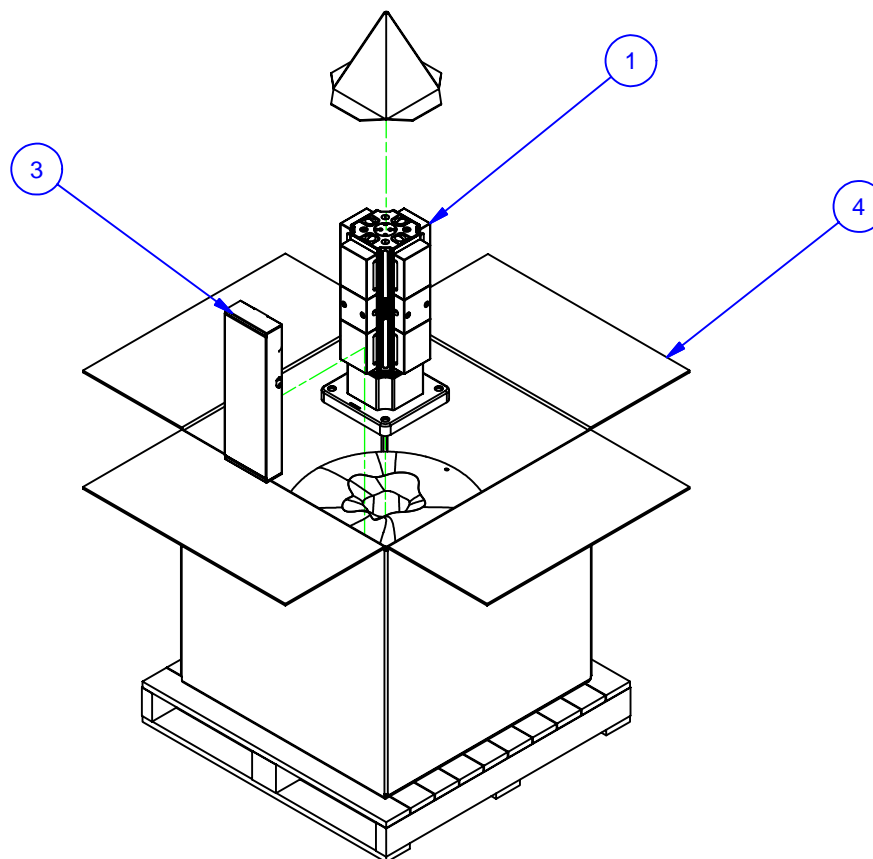

TABLE 1:

No	QTY	PN	ITEM	TYPE	FAM	STYLE	WEIGHT (g)
1	1	186-1-10812	MULTI-LOK ASSEMBLY	DECKEL MAHO DMU 70H duoBLOCK	5ML1040-41	115mm RISER	58240
2	1	185-2-10026	KIT	PP TO PALLET - MOD BP	MODULAR BASEPLATE	CUSTOM	444
3	1	185-0-10003	KIT	TOOLS	5ML10-41	STANDARD	404
4	1	185-0-10001	PACKAGING	SHIPPING CONTAINER	MULTI-LOK WORK PKG.	36" X 36" X 30" TALL	25890
5	1	185-2-10051	KIT	PILOT PLUG	MODULAR BASEPLATE	CUSTOM 50mm, 45mm LONG	676



MATERIAL:	
HARDNESS:	NA
COATING:	NA
WEIGHT:	85000 g
COMMENTS:	

UNSPECIFIED TOLERANCES:
 X ±0.2
 X.X ±0.1
 X.XX ±0.05
 ANGLES ±0.5°
 ALL DIMENSIONS ARE MILLIMETERS.

CHICK 500 Keystone Drive
 Warrendale, PA USA
 (800) 33-CHICK • (724) 772-1644
www.chick-workholding.com

UNSPECIFIED EDGES: BREAK 0.3 TO 0.8
 UNSPECIFIED FILLETS: RADIUS 0.3 MAX

ITEM:	WORK PKG - HMC		
TYPE:	DECKEL MAHO DMC 70H duoBLOCK		
FAM:	5ML1040-41		
STYLE:	250 SQ BASE X 550 TALL		
BCE	1 OF 4	5HP-DECK-00029	REV
7/13/2006			A3

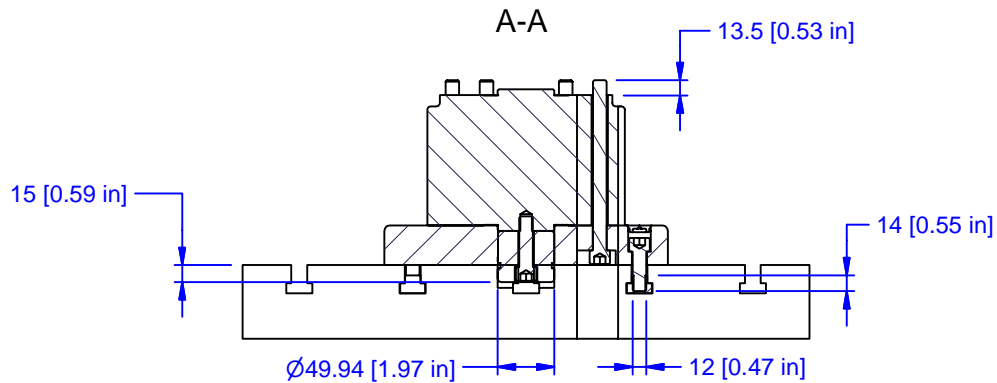
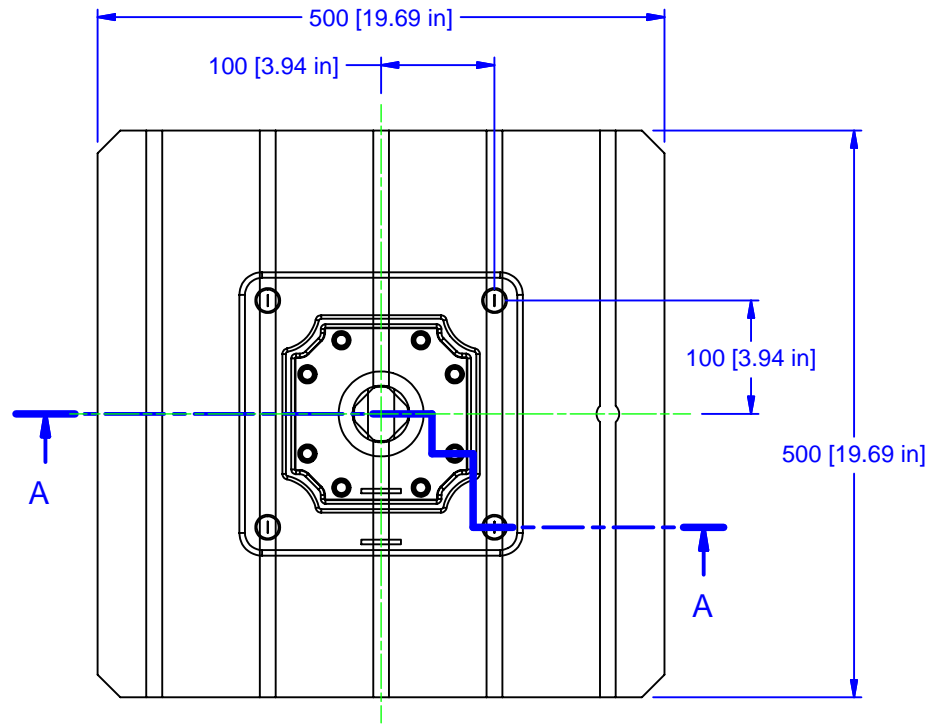

MATERIAL:	
HARDNESS:	NA
COATING:	NA
WEIGHT:	85000 g
COMMENTS:	

UNSPECIFIED TOLERANCES:	
X	± 0.2
X.X	± 0.1
X.XX	± 0.05
ANGLES	$\pm 0.5^\circ$
ALL DIMENSIONS ARE MILLIMETERS.	

CHICK 500 Keystone Drive
Warrendale, PA USA
(800) 33-CHICK • (724) 772-1644
www.chick-workholding.com

UNSPECIFIED EDGES: BREAK 0.3 TO 0.8
UNSPECIFIED FILLETS: RADIUS 0.3 MAX

ITEM:	WORK PKG - HMC		
TYPE:	DECKEL MAHO DMC 70H duoBLOCK		
FAM:	5ML1040-41		
STYLE:	250 SQ BASE X 550 TALL		
BCE	2 OF 4	5HP-DECK-00029	REV
7/13/2006			A3

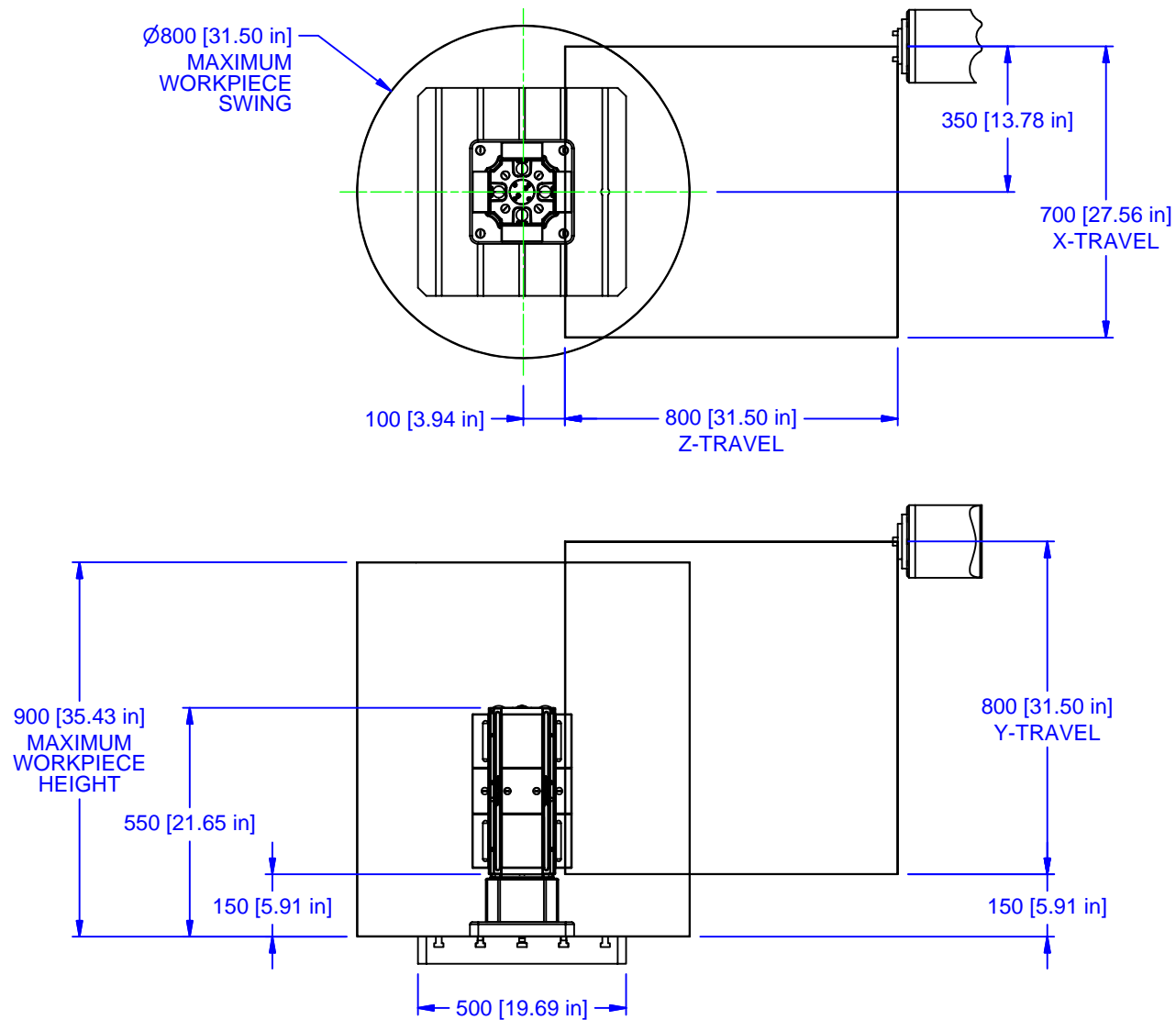

MATERIAL:	UNSPECIFIED TOLERANCES: X ± 0.2 X.X ± 0.1 X.XX ± 0.05 ANGLES $\pm 0.5^\circ$ ALL DIMENSIONS ARE MILLIMETERS.	CHICK 500 Keystone Drive Warrendale, PA USA (800) 33-CHICK • (724) 772-1644 www.chick-workholding.com	ITEM: WORK PKG - HMC	BCE 3 OF 4 7/13/2006	REV A3
HARDNESS: NA			TYPE: DECKEL MAHO DMC 70H duoBLOCK		
COATING: NA			FAM: 5ML1040-41		
WEIGHT: 85000 g			STYLE: 250 SQ BASE X 550 TALL		
COMMENTS:			UNSPECIFIED EDGES: BREAK 0.3 TO 0.8 UNSPECIFIED FILLETS: RADIUS 0.3 MAX		

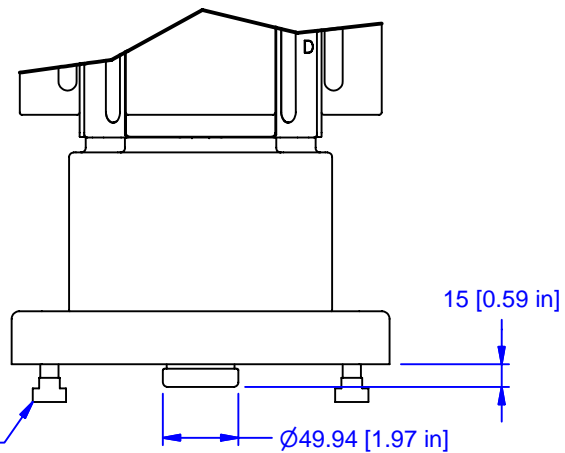
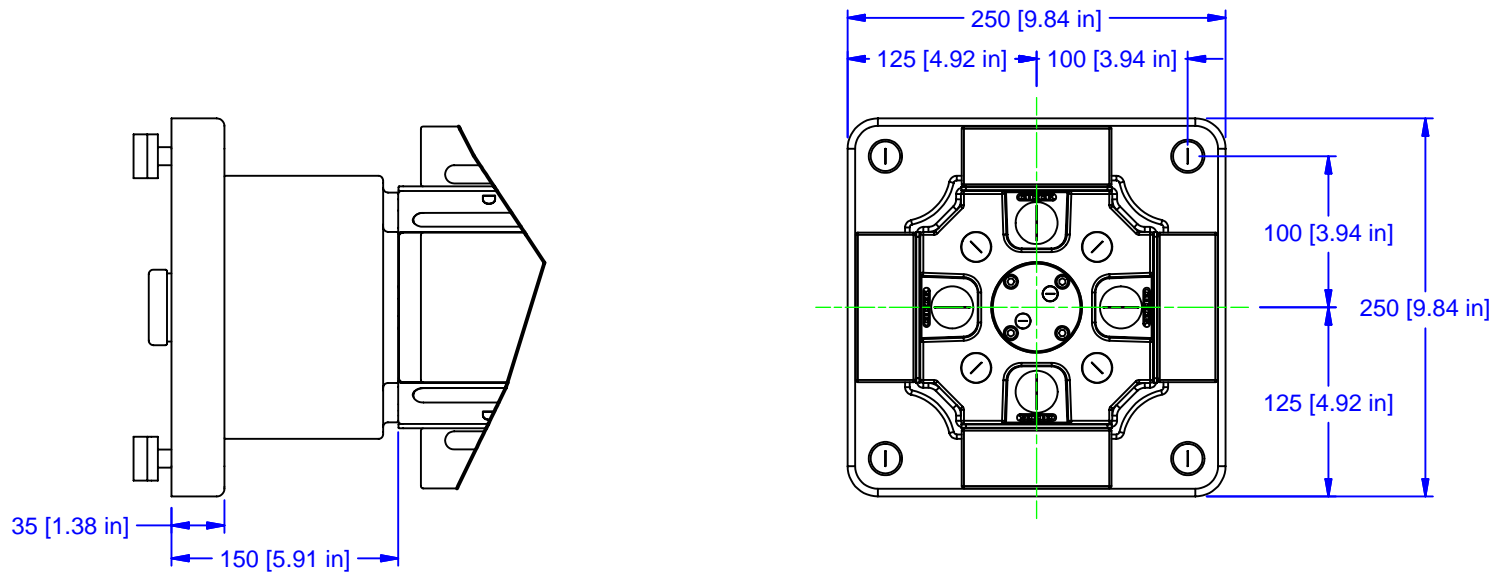

4x
M12 SHCS / 14mm T-NUT

MATERIAL:	
HARDNESS: NA	
COATING: NA	
WEIGHT: 85000 g	
COMMENTS:	

UNSPECIFIED TOLERANCES:
 X ±0.2
 X.X ±0.1
 X.XX ±0.05
 ANGLES ±0.5°
 ALL DIMENSIONS ARE MILLIMETERS.

CHICK 500 Keystone Drive
 Warrendale, PA USA
 (800) 33-CHICK • (724) 772-1644
 www.chick-workholding.com
 UNSPECIFIED EDGES: BREAK 0.3 TO 0.8
 UNSPECIFIED FILLETS: RADIUS 0.3 MAX

ITEM: WORK PKG - HMC	REV
TYPE: DECKEL MAHO DMC 70H duoBLOCK	A3
FAM: 5ML1040-41	
STYLE: 250 SQ BASE X 550 TALL	
BCE 4 OF 4	5HP-DECK-00029
7/13/2006	