

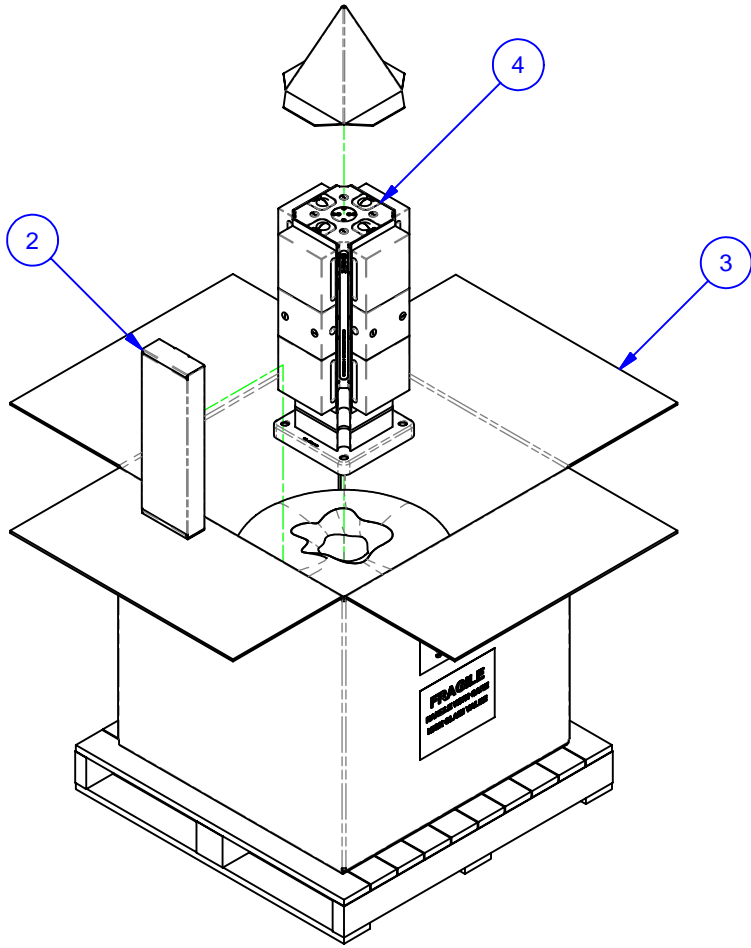

PARTS LIST						
No	QTY	PN	ITEM	TYPE	FAM	STYLE
1	1	185-2-10026	KIT	BASEPLATE MOUNTING	14mm T-SLOT	(4) M12 X 35 SHCS
2	1	185-0-10002	KIT	TOOLS	5ML15-41	STANDARD
3	1	185-0-10006	PACKAGING	SHIPPING CONTAINER	HMC WORK PKG.	36x36x30 [M16 W/8" BOLTS]
4	1	186-1-11499	MULTI-LOK ASSEMBLY	MODULAR BASEPLATE, CUSTOM BUSHING	5ML1550-41	250 SQ BASE X 650 TALL



MATERIAL: NA	UNSPECIFIED TOLERANCES: X ±0.2 X.X ±0.1 X.XX ±0.05 ANGLES ±0.5° ALL DIMENSIONS ARE MILLIMETERS.	 (800) 332-4425 (724) 772-1644 www.ChickWorkholding.com	ITEM: WORK PKG - HMC						
HARDNESS: NA			TYPE: DECKEL MAHO DMC 55 H (HYDRAULIC)						
COATING: NA			FAM: 5ML1550-41						
WEIGHT: 140200 g			STYLE: 250 SQ BASE X 650 TALL						
COMMENTS:			<table border="1"> <tr> <td>BCE</td> <td>1 OF 4</td> <td>5HP-DECK-00108</td> <td>REV A</td> </tr> <tr> <td colspan="2">7/30/2008</td> <td></td> <td></td> </tr> </table>	BCE	1 OF 4	5HP-DECK-00108	REV A	7/30/2008	
BCE	1 OF 4	5HP-DECK-00108	REV A						
7/30/2008									

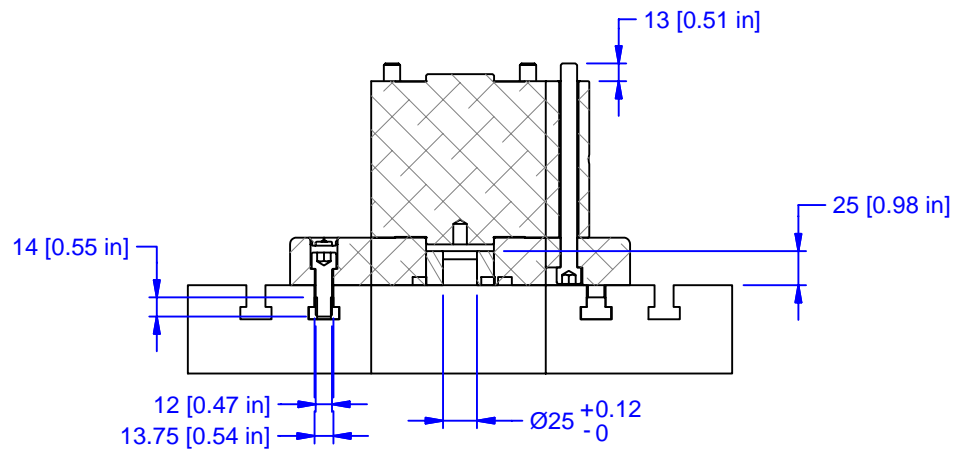
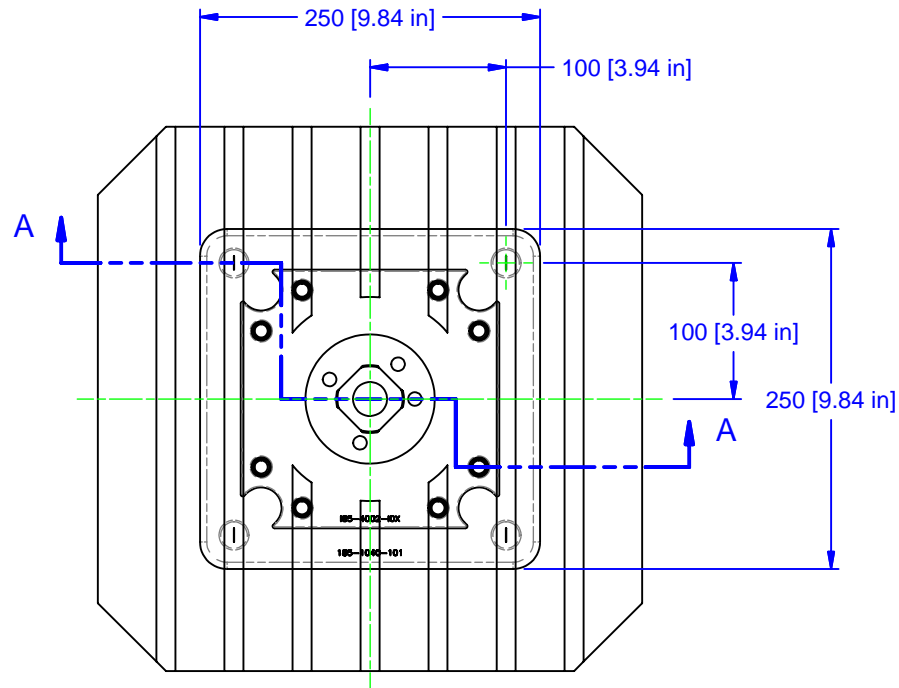

SECTION A-A

MATERIAL: NA
HARDNESS: NA
COATING: NA
WEIGHT: 140200 g
COMMENTS:

UNSPECIFIED TOLERANCES:
 X ±0.2
 X.X ±0.1
 X.XX ±0.05
 ANGLES ±0.5°
 ALL DIMENSIONS ARE MILLIMETERS.

CHICK (800) 332-4425
 (724) 772-1644
www.ChickWorkholding.com

UNSPECIFIED EDGES: BREAK 0.3 TO 0.8
 UNSPECIFIED FILLETS: RADIUS 0.3 MAX

ITEM: WORK PKG - HMC		REV A
TYPE: DECKEL MAHO DMC 55 H (HYDRAULIC)		
FAM: 5ML1550-41		5HP-DECK-00108
STYLE: 250 SQ BASE X 650 TALL		
BCE	2 OF 4	
7/30/2008		

Ø630 [24.80 in]
MAXIMUM
WORKPIECE
SWING

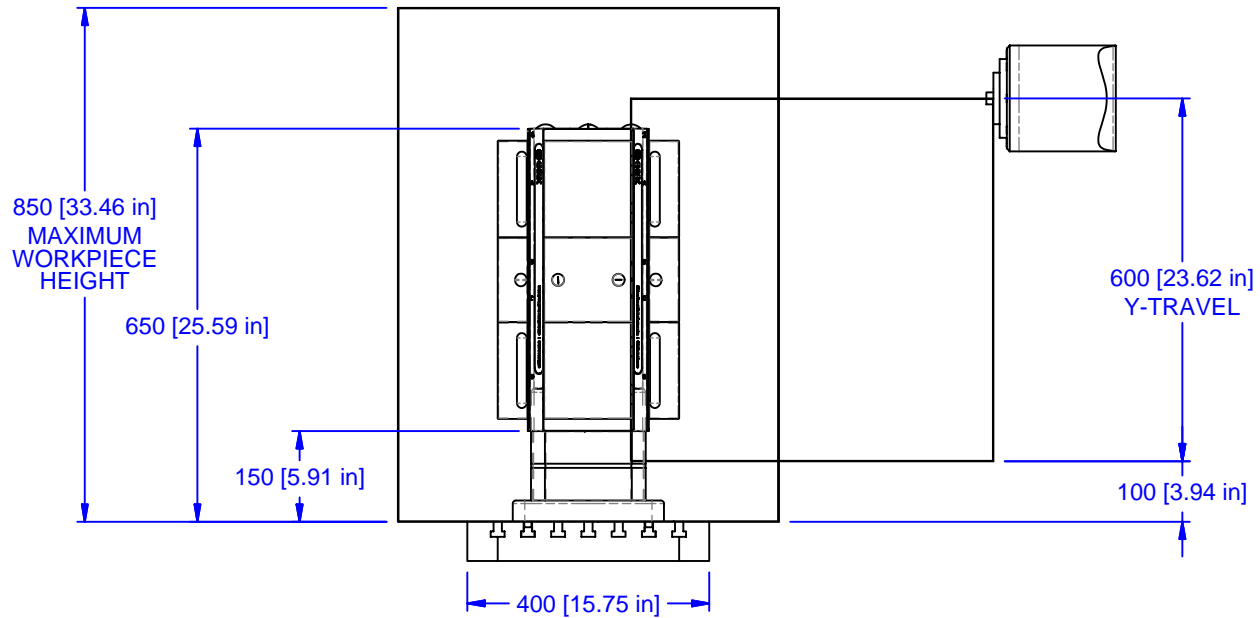
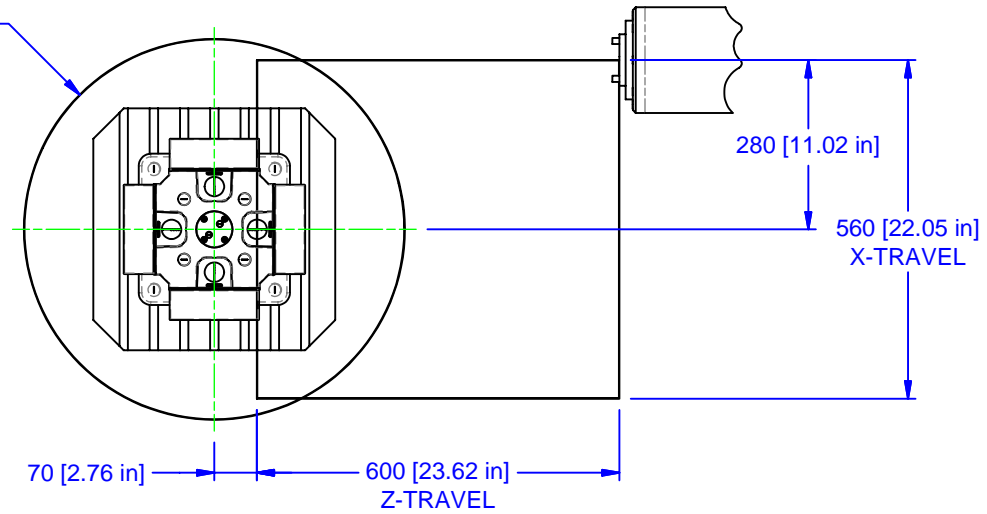

MATERIAL:	NA
HARDNESS:	NA
COATING:	NA
WEIGHT:	140200 g
COMMENTS:	

UNSPECIFIED TOLERANCES:
 X ±0.2
 X.X ±0.1
 X.XX ±0.05
 ANGLES ±0.5°
 ALL DIMENSIONS ARE MILLIMETERS.

CHICK (800) 332-4425
 (724) 772-1644
www.ChickWorkholding.com

ITEM:	WORK PKG - HMC		
TYPE:	DECKEL MAHO DMC 55 H (HYDRAULIC)		
FAM:	5ML1550-41		
STYLE:	250 SQ BASE X 650 TALL		
BCE	3 OF 4	5HP-DECK-00108	REV A
7/30/2008			

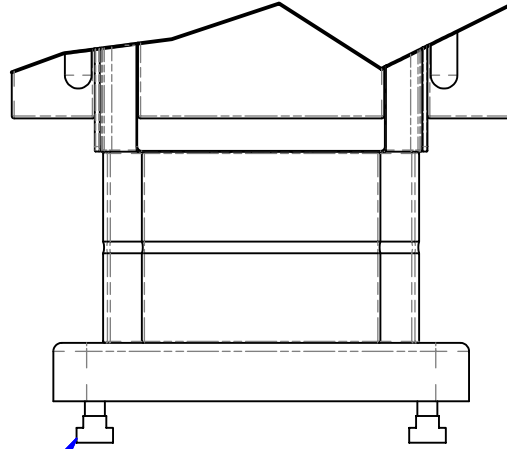
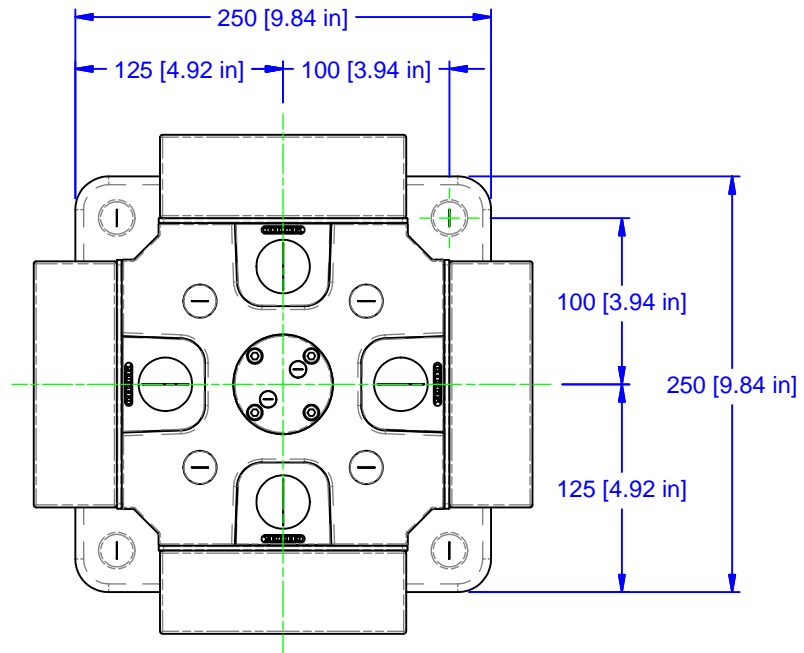
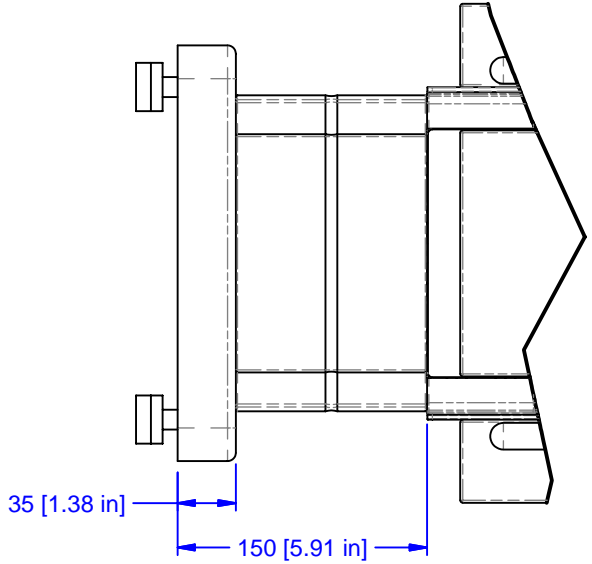

4x
M12 SHCS / 14mm T-NUT

MATERIAL: NA	UNSPECIFIED TOLERANCES: X ±0.2 X.X ±0.1 X.XX ±0.05 ANGLES ±0.5° ALL DIMENSIONS ARE MILLIMETERS.	 (800) 332-4425 (724) 772-1644 www.ChickWorkholding.com	ITEM: WORK PKG - HMC	BCE 4 OF 4 SHP-DECK-00108 REV A
HARDNESS: NA			TYPE: DECKEL MAHO DMC 55 H (HYDRAULIC)	
COATING: NA			FAM: 5ML1550-41	
WEIGHT: 140200 g			STYLE: 250 SQ BASE X 650 TALL	
COMMENTS:			7/30/2008	