

PARTS LIST						
No	QTY	PN	ITEM	TYPE	FAM	STYLE
1	1	185-0-10002	KIT	TOOLS	5ML15-41	STANDARD
2	1	185-0-10005	PACKAGING	SHIPPING CONTAINER	HMC WORK PKG.	36x36x30 [M12 W/8" BOLTS]
3	1	185-2-10051	KIT	PILOT PLUG	MODULAR BASEPLATE	CUSTOM 50mm, 45mm LONG
4	1	185-2-10095	KIT	BASEPLATE MOUNTING	14mm T-SLOT	(4) M12 X 30 SHCS
5	1	186-1-10828	MULTI-LOK ASSEMBLY	DIN M12 TAP - 50mm GRID	5ML1550-41	115mm TALL RISER

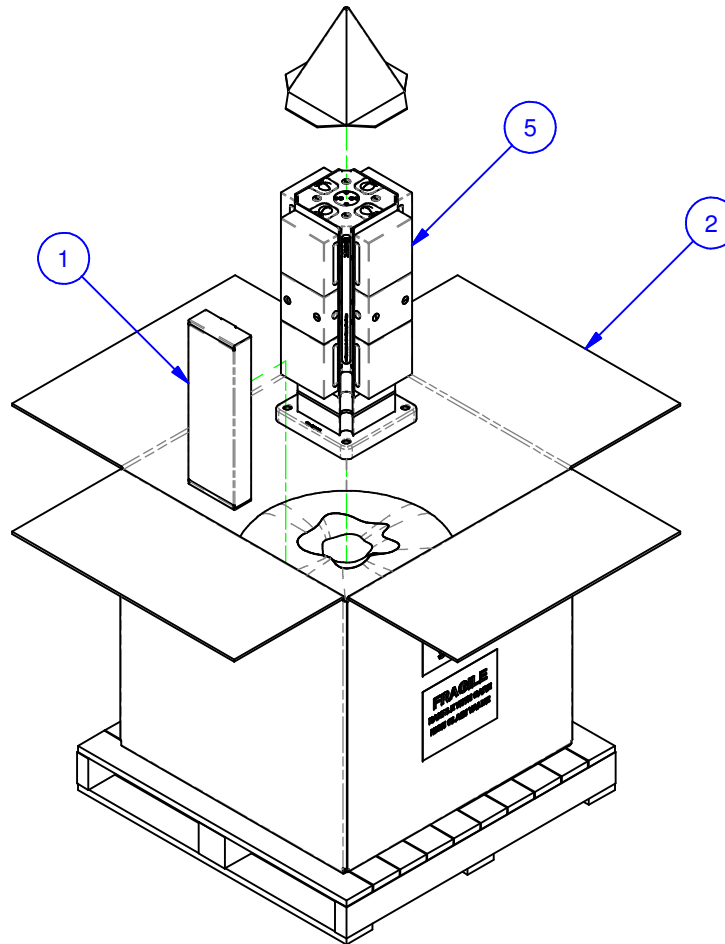

MATERIAL: NA
HARDNESS: NA
COATING: NA
WEIGHT: 140387 g
COMMENTS:

UNSPECIFIED TOLERANCES:
 X ±0.2
 X.X ±0.1
 X.XX ±0.05
 ANGLES ±0.5°
 ALL DIMENSIONS ARE MILLIMETERS.

CHICK (800) 332-4425
 (724) 772-1644
www.ChickWorkholding.com
 UNSPECIFIED EDGES: BREAK 0.3 TO 0.8
 UNSPECIFIED FILLETS: RADIUS 0.3 MAX

ITEM: WORK PKG - HMC		REV A
TYPE: DECKEL MAHO DMC 65 H_T-C		
FAM: 5ML1550-41		5HP-DECK-00128
STYLE: 250 SQ BASE X 650 TALL		
TDD	1 OF 4	
7/26/2011		

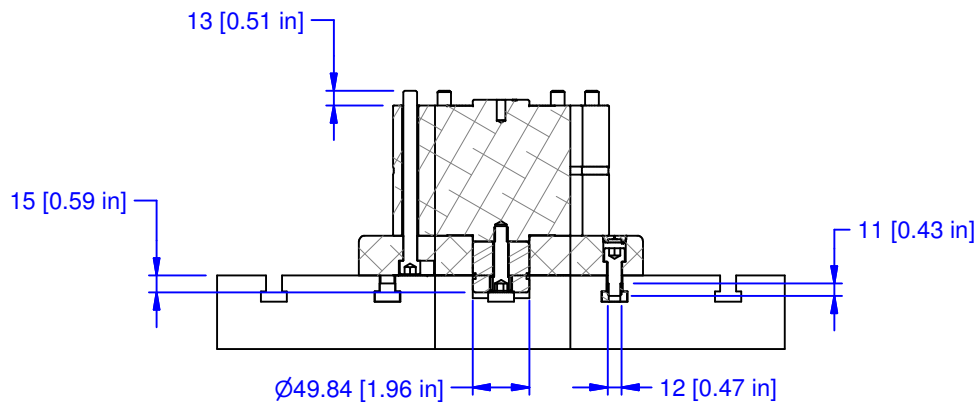
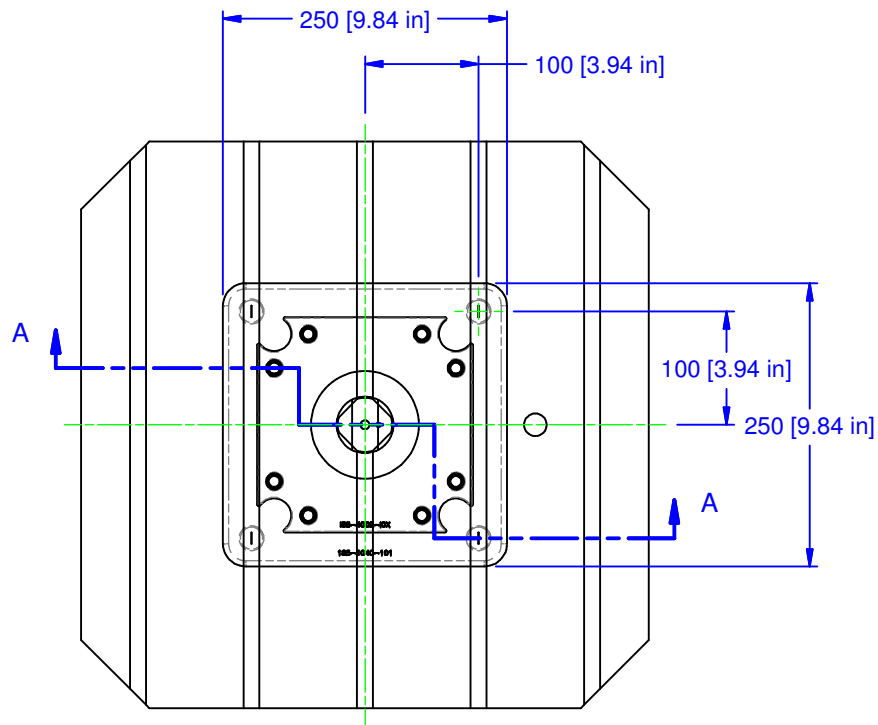

SECTION A-A

MATERIAL:	NA
HARDNESS:	NA
COATING:	NA
WEIGHT:	140387 g
COMMENTS:	

UNSPECIFIED TOLERANCES:
 X ±0.2
 X.X ±0.1
 X.XX ±0.05
 ANGLES ±0.5°
 ALL DIMENSIONS ARE MILLIMETERS.

CHICK (800) 332-4425
 (724) 772-1644
www.ChickWorkholding.com

UNSPECIFIED EDGES: BREAK 0.3 TO 0.8
 UNSPECIFIED FILLETS: RADIUS 0.3 MAX

ITEM:	WORK PKG - HMC		
TYPE:	DECKEL MAHO DMC 65 H_T-C		
FAM:	5ML1550-41		
STYLE:	250 SQ BASE X 650 TALL		
TDD	2 OF 4	SHP-DECK-00128	REV A
7/26/2011			

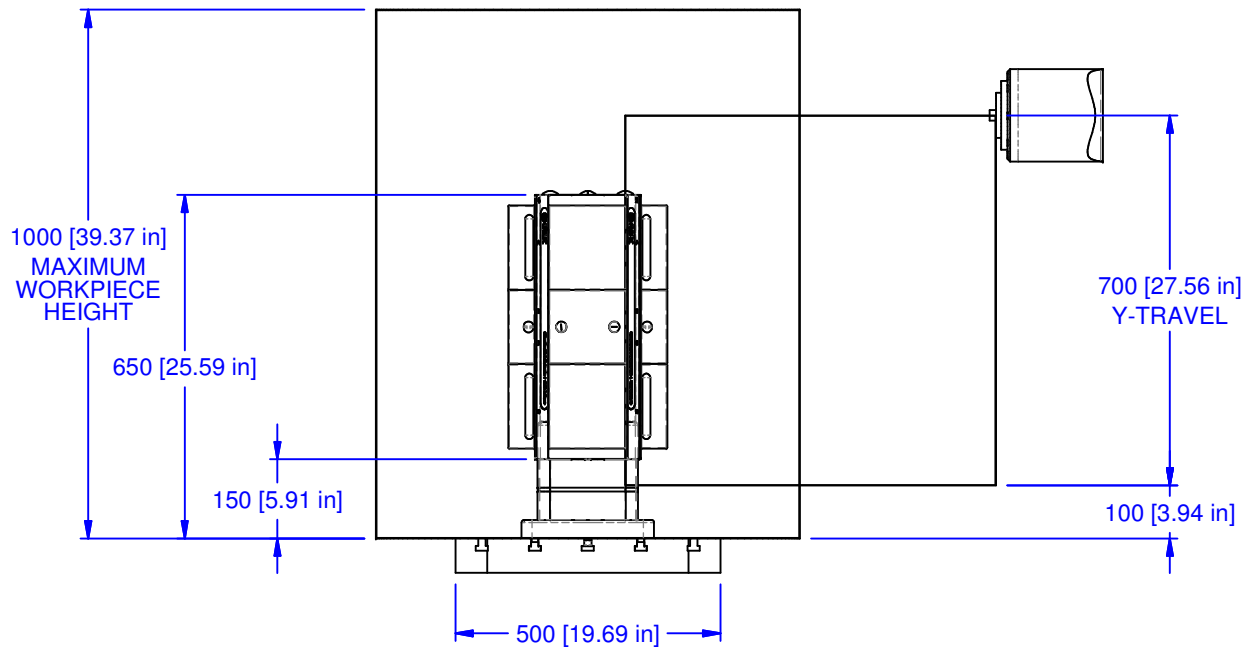
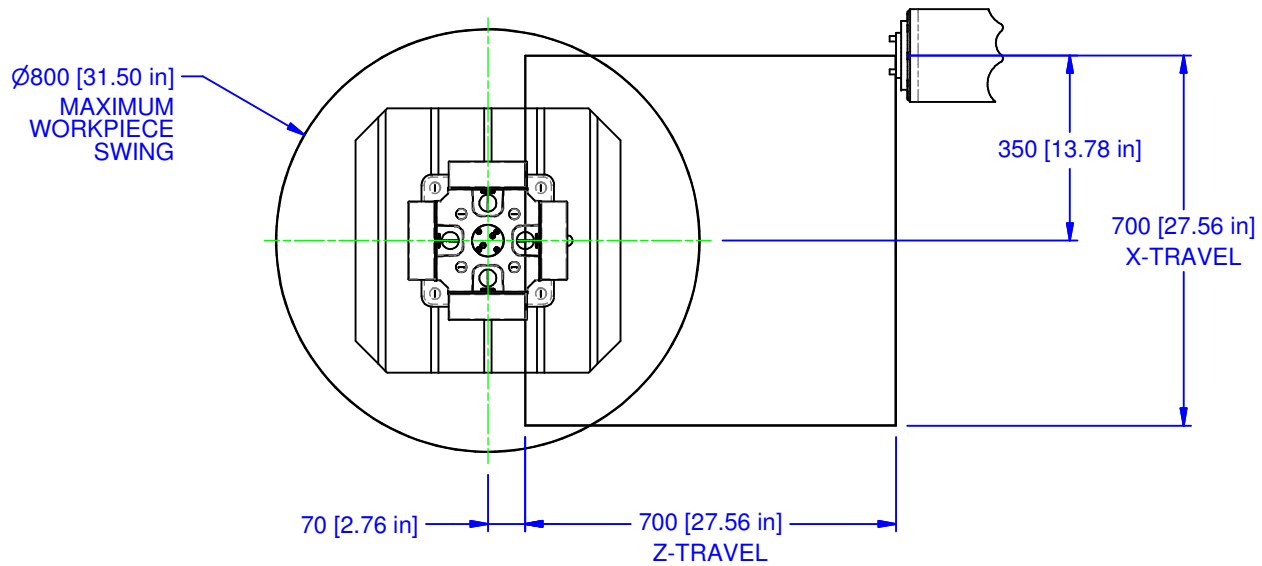

MATERIAL:	NA
HARDNESS:	NA
COATING:	NA
WEIGHT:	140387 g
COMMENTS:	

UNSPECIFIED TOLERANCES:	
X	±0.2
X.X	±0.1
X.XX	±0.05
ANGLES	±0.5°
ALL DIMENSIONS ARE MILLIMETERS.	

 (800) 332-4425
 (724) 772-1644
www.ChickWorkholding.com

UNSPECIFIED EDGES: BREAK 0.3 TO 0.8
 UNSPECIFIED FILLETS: RADIUS 0.3 MAX

ITEM:	WORK PKG - HMC		
TYPE:	DECKEL MAHO DMC 65 H_T-C		
FAM:	5ML1550-41		
STYLE:	250 SQ BASE X 650 TALL		
TDD	3 OF 4	5HP-DECK-00128	REV A
7/26/2011			

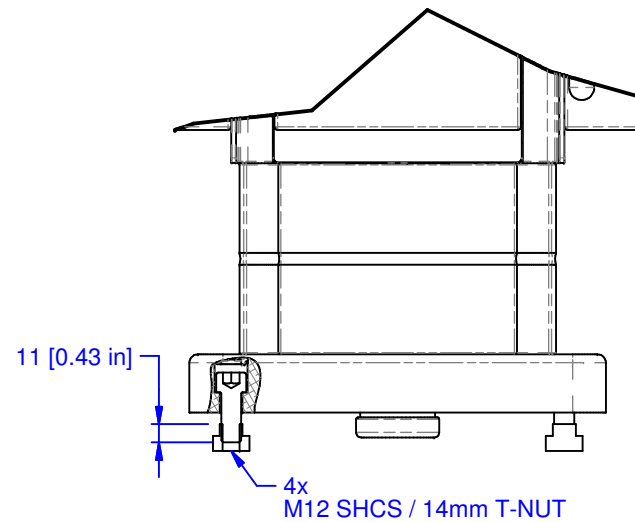
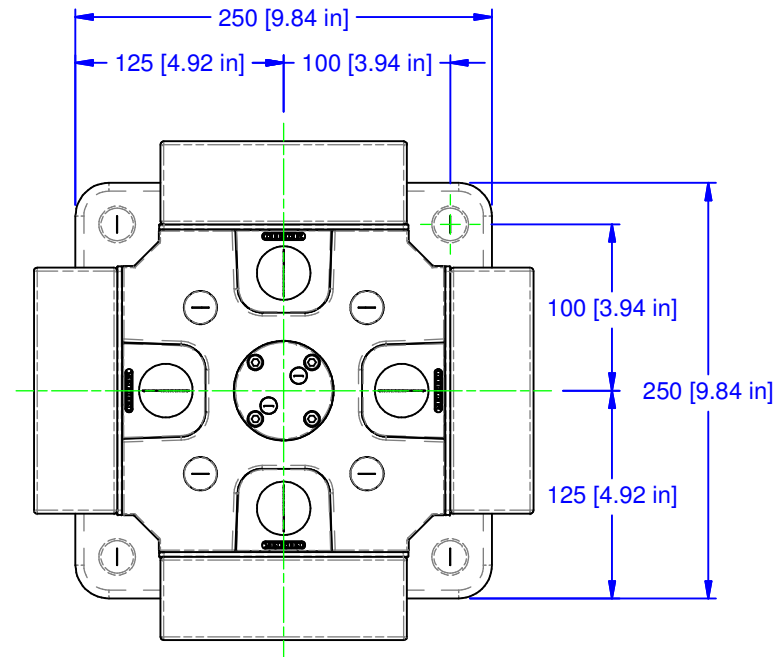
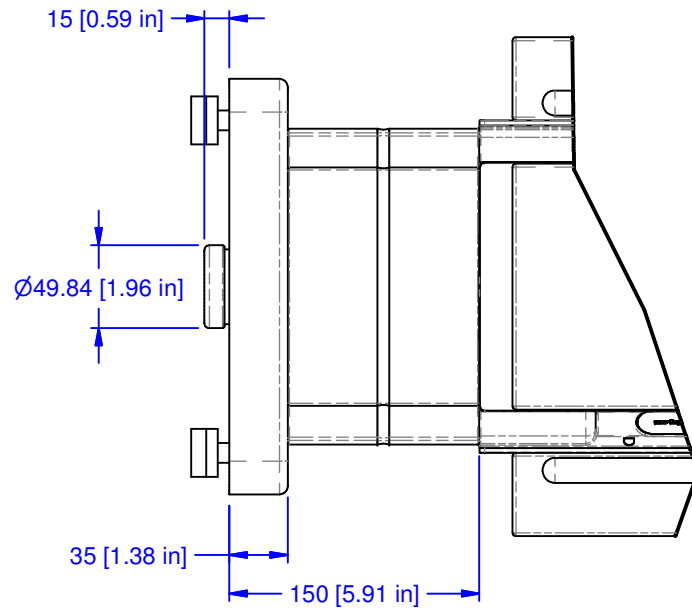

MATERIAL: NA
HARDNESS: NA
COATING: NA
WEIGHT: 140387 g
COMMENTS:

UNSPECIFIED TOLERANCES:
 X ±0.2
 X.X ±0.1
 X.XX ±0.05
 ANGLES ±0.5°
 ALL DIMENSIONS ARE MILLIMETERS.

CHICK (800) 332-4425
 (724) 772-1644
www.ChickWorkholding.com

ITEM: WORK PKG - HMC
TYPE: DECKEL MAHO DMC 65 H_T-C
FAM: 5ML1550-41
STYLE: 250 SQ BASE X 650 TALL

TDD	4 OF 4	5HP-DECK-00128	REV A
7/26/2011			