

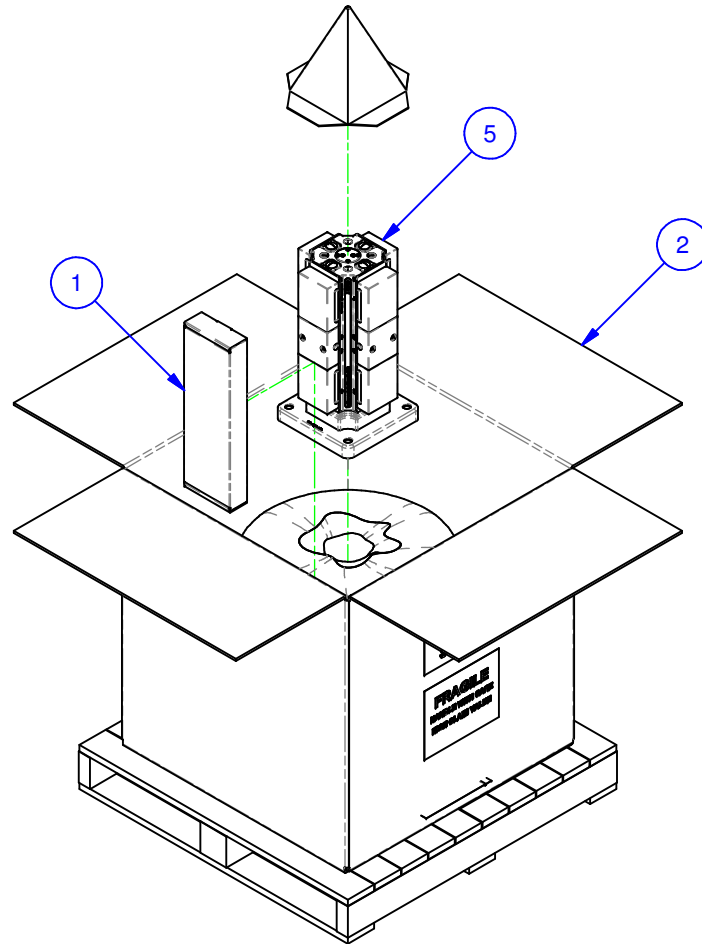

PARTS LIST						
No	QTY	PN	ITEM	TYPE	FAM	STYLE
1	1	185-0-10003	KIT	TOOLS	5ML10-41	STANDARD
2	1	185-0-10005	PACKAGING	SHIPPING CONTAINER	HMC WORK PKG.	36x36x30 [M12 W/8" BOLTS]
3	1	185-2-10051	KIT	PILOT PLUG	MODULAR BASEPLATE	CUSTOM 50mm, 45mm LONG
4	1	185-2-10095	KIT	BASEPLATE MOUNTING	14mm T-SLOT	(4) M12 X 30 SHCS
5	1	186-1-10810	MULTI-LOK ASSEMBLY	HAAS_EC-400_M_PARTIAL PALLET	5ML1040-41	45mm TALL RISER



MATERIAL: <a href="#">NA</a>	UNSPECIFIED TOLERANCES: X ±0.2 X.X ±0.1 X.XX ±0.05 ANGLES ±0.5° ALL DIMENSIONS ARE MILLIMETERS.	 (800) 332-4425 (724) 772-1644 <a href="http://www.ChickWorkholding.com">www.ChickWorkholding.com</a>	ITEM: <a href="#">WORK PKG - HMC</a>		
HARDNESS: <a href="#">NA</a>			TYPE: <a href="#">DECKEL MAHO DMC 60 H_T-C</a>		
COATING: <a href="#">NA</a>			FAM: <a href="#">5ML1040-41</a>		
WEIGHT: <a href="#">79030 g</a>			STYLE: <a href="#">250 SQ BASE X 480 TALL</a>		
COMMENTS:			TDD	1 OF 4	8/23/2011