

5HP-HAAS-00070

This workholding package is designed for your HAAS EC-300 machining center.



Workholding package



Workholding package
in machine envelope

Notes

CHICK WORKHOLDING SOLUTIONS, INC.
500 Keystone Drive • Warrendale, PA 15086 USA
Phone: (724) 772-1644 • Fax: (724) 772-1633
www.ChickWorkholding.com

5HP-HAAS-00070

This workholding package is designed for your HAAS EC-300 machining center.

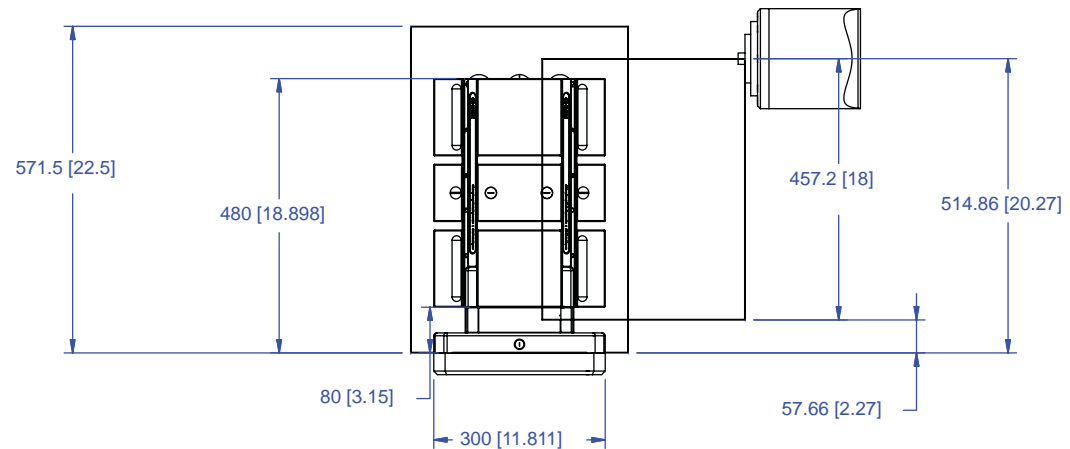
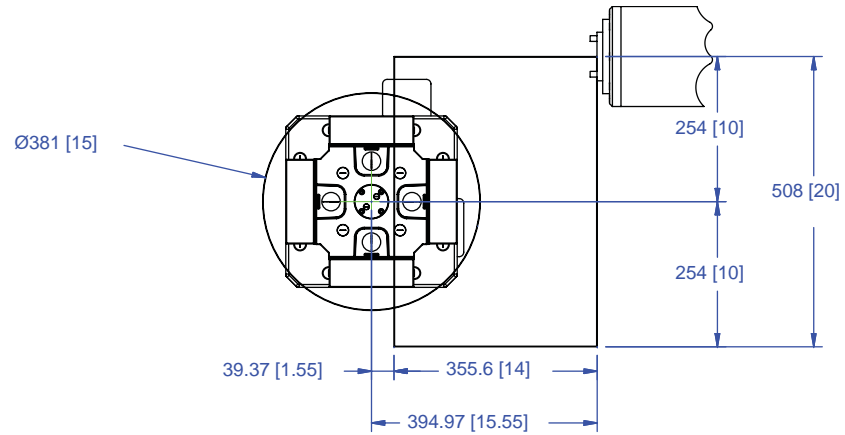

Notes

Machine travel may be limited by mechanical interference and/or machine safety zones. Please consult your machine's operating instructions for more information.

All dimensions are MM [IN]

CHICK WORKHOLDING SOLUTIONS, INC.
 500 Keystone Drive • Warrendale, PA 15086 USA
 Phone: (724) 772-1644 • Fax: (724) 772-1633
www.ChickWorkholding.com

5HP-HAAS-00070

This workholding package is designed for your HAAS EC-300 machining center.

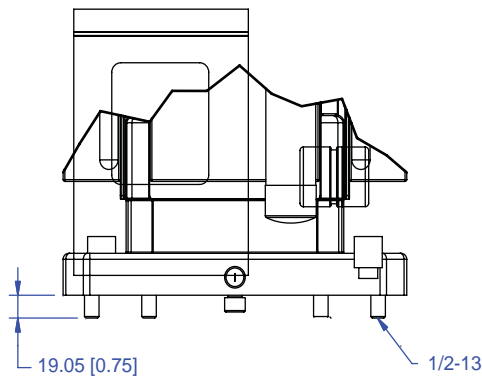
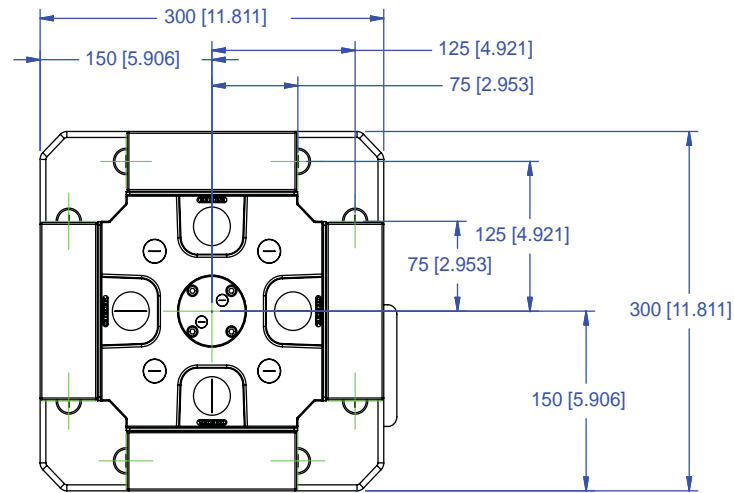
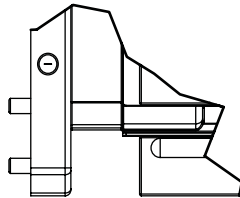

Notes
All dimensions are MM [IN]

CHICK WORKHOLDING SOLUTIONS, INC.
500 Keystone Drive • Warrendale, PA 15086 USA
Phone: (724) 772-1644 • Fax: (724) 772-1633
www.ChickWorkholding.com

Batch Production

Machinable accessories are the optimal solution for batch production. They offer QwikChange™ and accurate repeat set ups to optimize the productivity of the machine center.

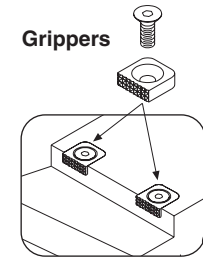
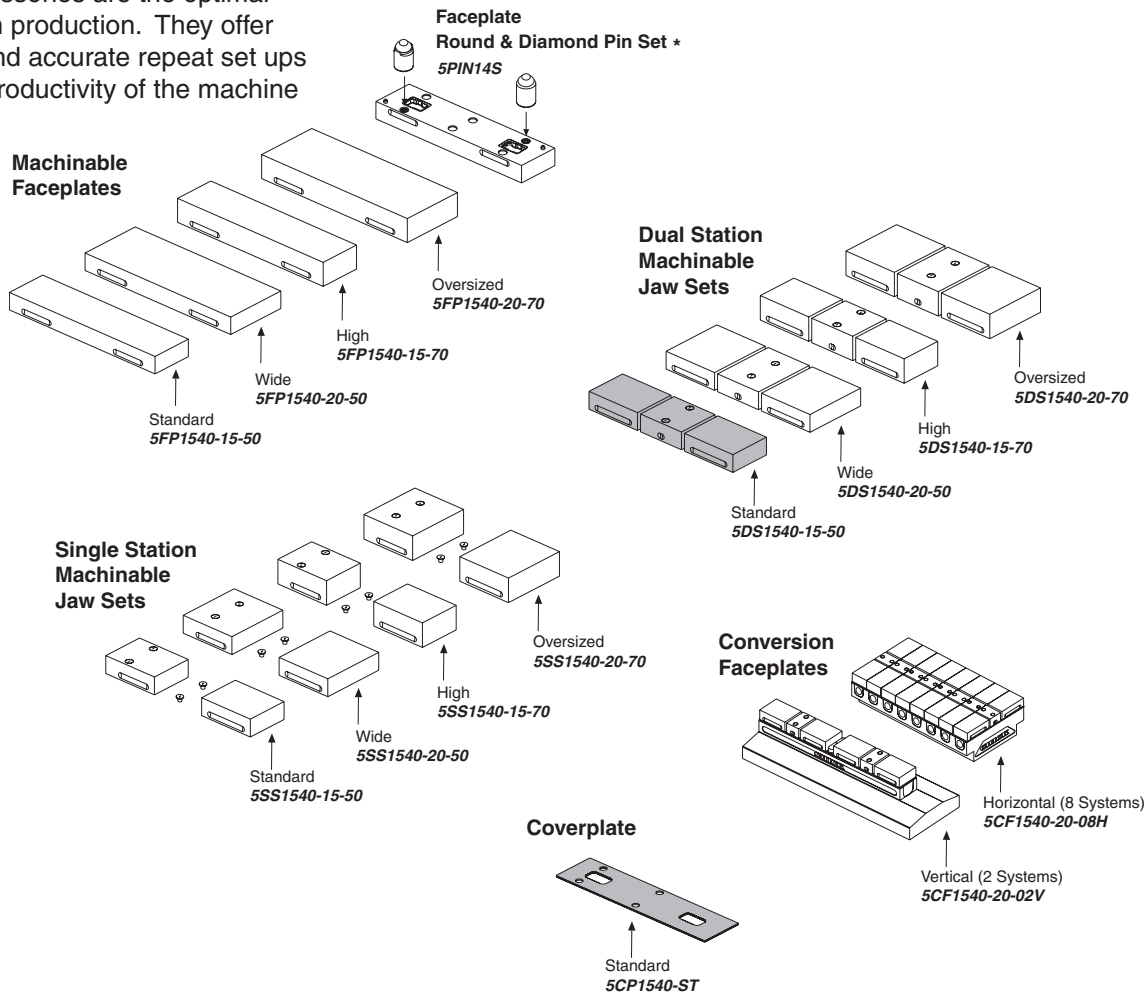

Grippers

Gripper #3
 Plain 005-2531
 Serrated 005-2532
 (L-9mm x W-9mm x T-8mm)

Gripper #4
 Plain 005-2541
 Serrated 005-2542
 (L-12mm x W-12mm x T-4.6mm)

Gripper #5
 Plain 005-2551
 Serrated 005-2552
 (L-15mm x W-15mm x T-5mm)

Gripper #6
 Plain 005-2561
 Serrated 005-2562
 (L-19mm x W-19mm x T-6mm)

Notes
 Grey item is included with a standard system

CHICK WORKHOLDING SOLUTIONS, INC.
 500 Keystone Drive • Warrendale, PA 15086 USA
 Phone: (724) 772-1644 • Fax: (724) 772-1633
 www.ChickWorkholding.com

Dedicated Fixturing

Machinable Faceplates provide QwikChange™ dedicated fixturing and are optimal for awkward or hard to hold parts. A mini pallet changer can be created by utilizing two Faceplates in tandem.

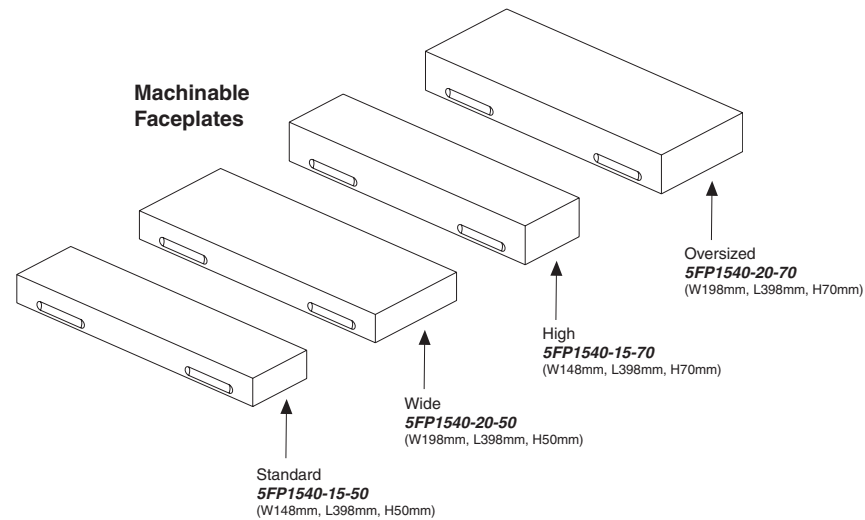

Notes

CHICK WORKHOLDING SOLUTIONS, INC.
500 Keystone Drive • Warrendale, PA 15086 USA
Phone: (724) 772-1644 • Fax: (724) 772-1633
www.ChickWorkholding.com

QwikChange Machinable Dual Station Jaws

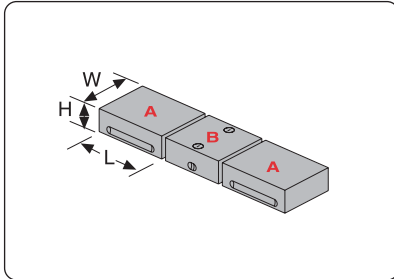

Individual Dual Station Jaws

Standard

- A** Moveable Jaw **5MJ1540-15-50**
(W148mm, H50mm, L135mm)
- B** Fixed Jaw **5FJ1540-15-50**
(W148mm, H50mm, L100mm)

Wide

- A** Moveable Jaw **5MJ1540-20-50**
(W198mm, H50mm, L135mm)
- B** Fixed Jaw **5FJ1540-20-50**
(W198mm, H50mm, L100mm)

High

- A** Moveable Jaw **5MJ1540-15-70**
(W148mm, H70mm, L135mm)
- B** Fixed Jaw **5FJ1540-15-70**
(W148mm, H70mm, L100mm)

Oversized

- A** Moveable Jaw **5MJ1540-20-70**
(W198mm, H70mm, L135mm)
- B** Fixed Jaw **5FJ1540-20-70**
(W198mm, H70mm, L100mm)

QwikChange Machinable Single Station Jaws

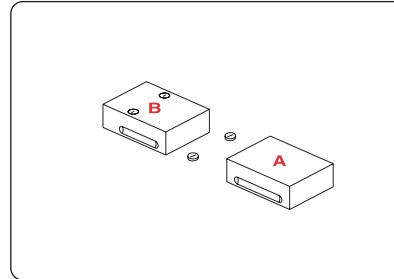

Individual Single Station Jaws

Standard

- A** Moveable Jaw **5MJ1540-15-50**
(W148mm, H50mm, L135mm)
- B** Fixed Jaw **5SJ1540-15-50**
(W148mm, H50mm, L135mm)

Wide

- A** Moveable Jaw **5MJ1540-20-50**
(W198mm, H50mm, L135mm)
- B** Fixed Jaw **5SJ1540-20-50**
(W198mm, H50mm, L135mm)

High

- A** Moveable Jaw **5MJ1540-15-70**
(W148mm, H70mm, L135mm)
- B** Fixed Jaw **5SJ1540-15-70**
(W148mm, H70mm, L135mm)

Oversized

- A** Moveable Jaw **5MJ1540-20-70**
(W198mm, H70mm, L135mm)
- B** Fixed Jaw **5SJ1540-20-70**
(W198mm, H70mm, L135mm)

Screws and Plugs

Dual Station

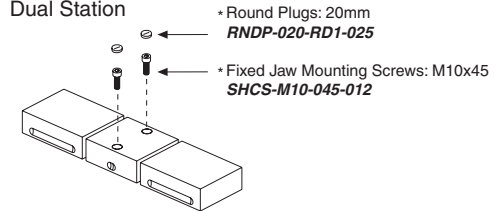

Single Station

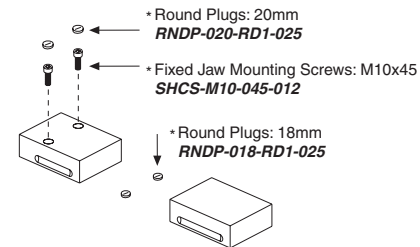

Faceplate Round & Diamond Pin Set

(Included w/ Faceplate purchase)

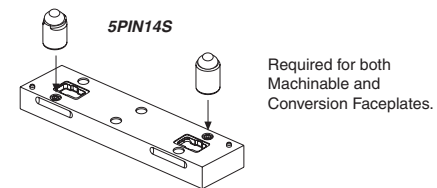

Notes

Grey or * item is included with a standard system

CHICK WORKHOLDING SOLUTIONS, INC.
500 Keystone Drive • Warrendale, PA 15086 USA
Phone: (724) 772-1644 • Fax: (724) 772-1633
www.ChickWorkholding.com

Dual Station

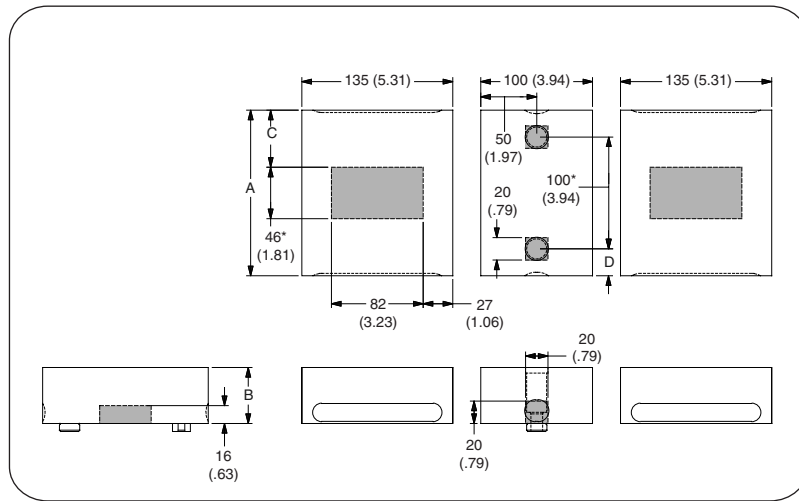

Item Number	Description	A	B	C	D
5DS1540-15-50	Standard	148 (5.83)	50 (1.97)	51 (2.01)	24 (.94)
5DS1540-15-70	High	148 (5.83)	70 (2.76)	51 (2.01)	24 (.94)
5DS1540-20-50	Wide	198 (7.80)	50 (1.97)	76 (2.99)	49 (1.93)
5DS1540-20-70	Oversized	198 (7.80)	70 (2.76)	76 (2.99)	49 (1.93)

Single Station

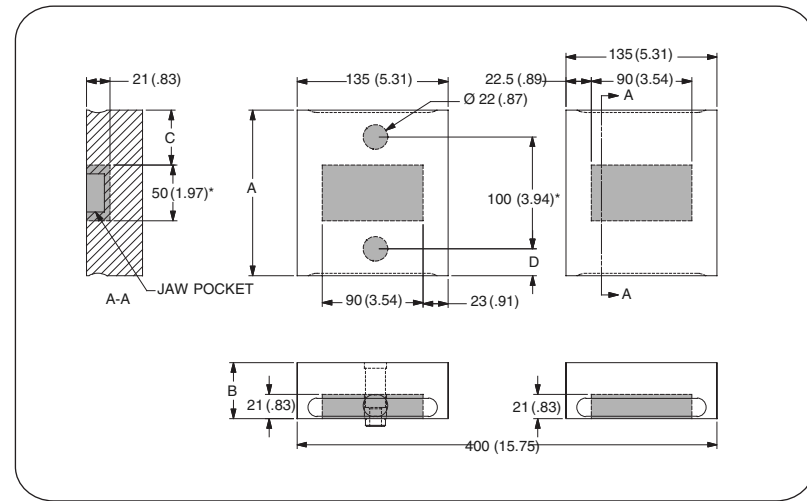

Item Number	Description	A	B	C	D
5SS1540-15-50	Standard	148 (5.83)	50 (1.97)	49 (1.93)	24 (.94)
5SS1540-15-70	High	148 (5.83)	70 (2.76)	49 (1.93)	24 (.94)
5SS1540-20-50	Wide	198 (7.80)	50 (1.97)	74 (2.91)	49 (1.93)
5SS1540-20-70	Oversized	198 (7.80)	70 (2.76)	74 (2.91)	49 (1.93)

Notes

Grey area indicates no cut zone
 All dimensions are MM [IN]
 Dimensions centered on the "A" dimension.

CHICK WORKHOLDING SOLUTIONS, INC.
 500 Keystone Drive • Warrendale, PA 15086 USA
 Phone: (724) 772-1644 • Fax: (724) 772-1633
www.ChickWorkholding.com

Dual Station

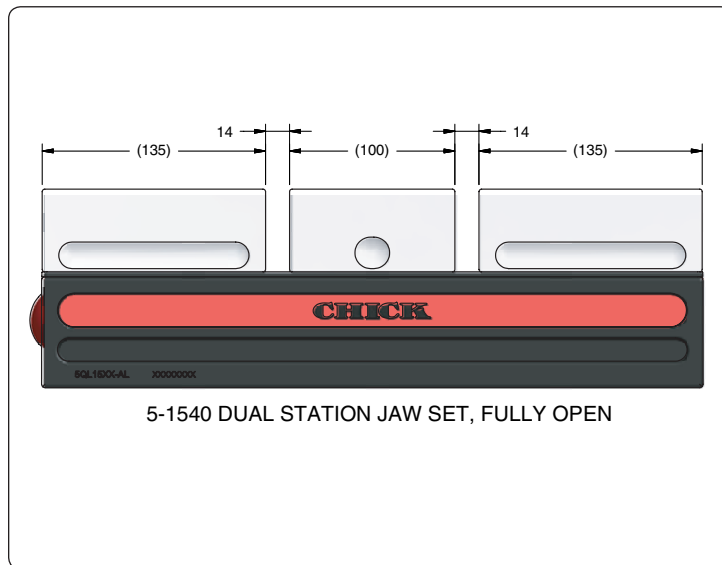

Single Station

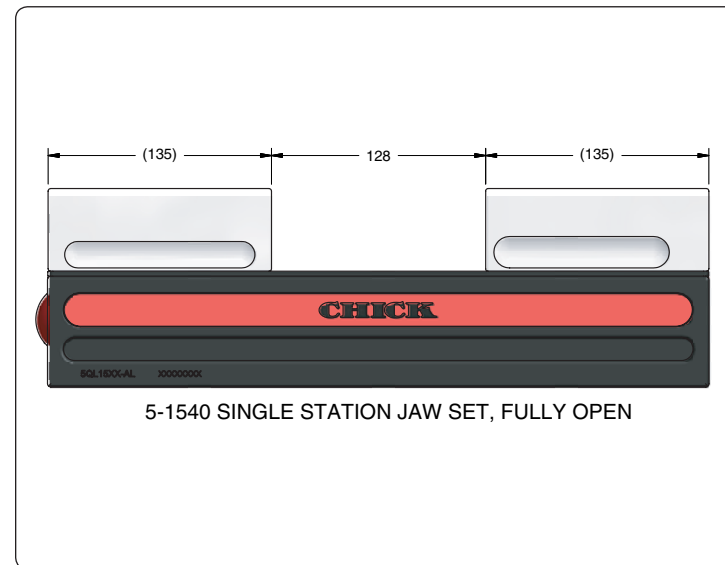

Notes

All dimensions are MM [IN]
 Additional closure is available with an Extended Travel Coverplate.
 Contact CHICK for details.

CHICK WORKHOLDING SOLUTIONS, INC.
 500 Keystone Drive • Warrendale, PA 15086 USA
 Phone: (724) 772-1644 • Fax: (724) 772-1633
www.ChickWorkholding.com

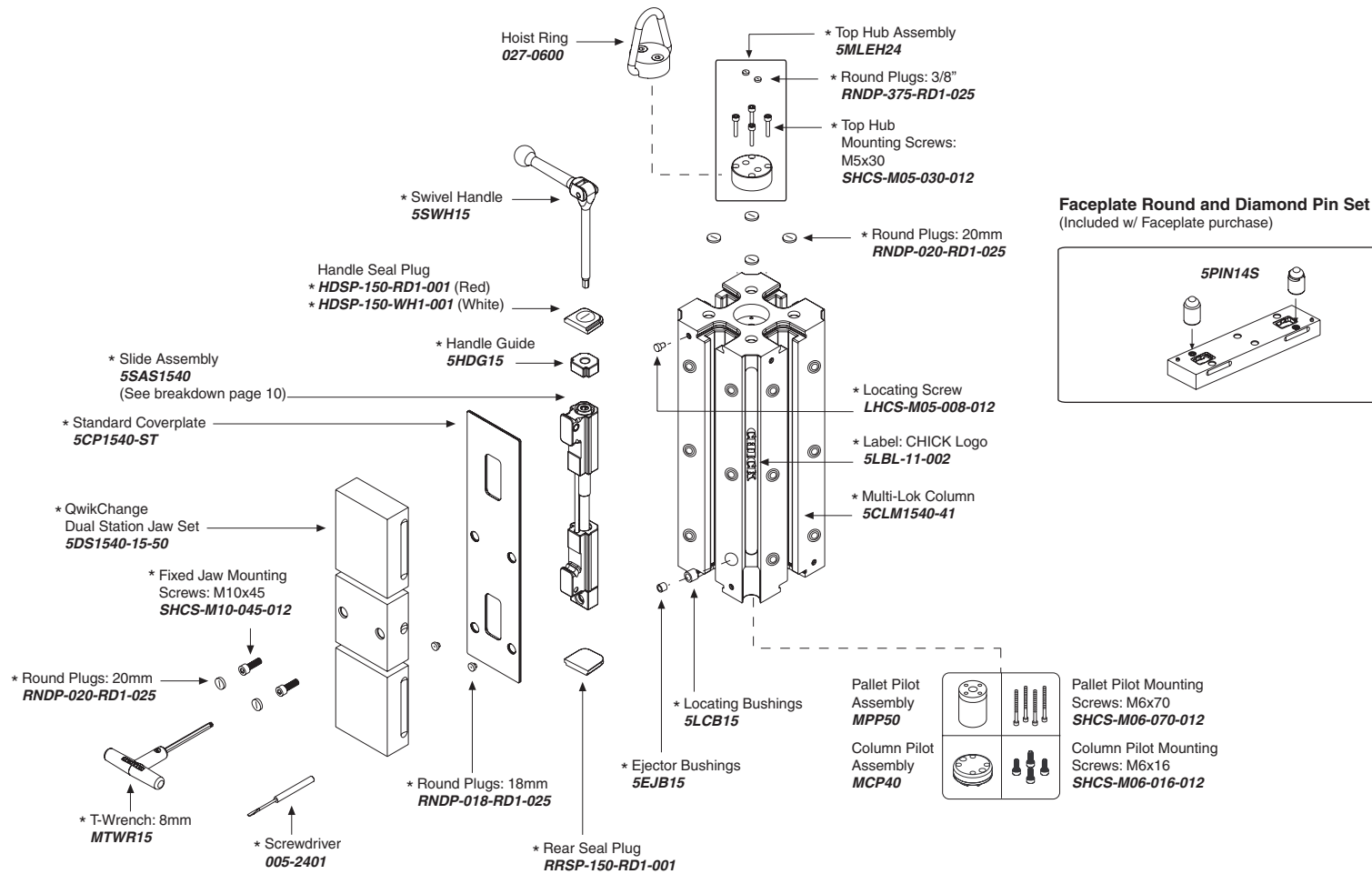

Notes

For QwikChange™ Jaw accessories, see pages 4-7

CHICK WORKHOLDING SOLUTIONS, INC.
 500 Keystone Drive • Warrendale, PA 15086 USA
 Phone: (724) 772-1644 • Fax: (724) 772-1633
www.ChickWorkholding.com

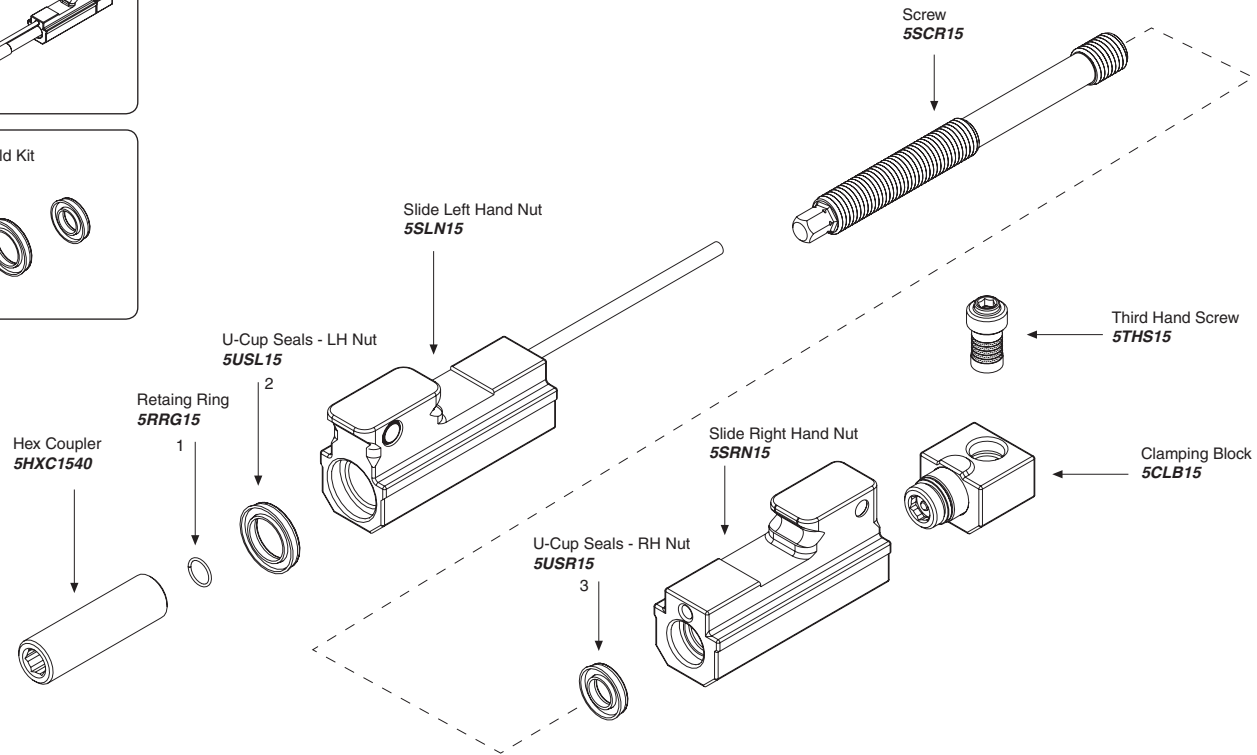
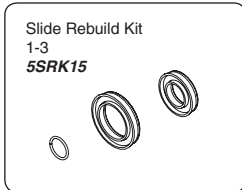
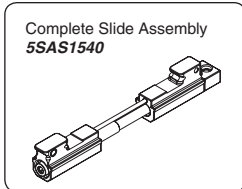

Notes

CHICK WORKHOLDING SOLUTIONS, INC.
 500 Keystone Drive • Warrendale, PA 15086 USA
 Phone: (724) 772-1644 • Fax: (724) 772-1633
www.ChickWorkholding.com

Pounds (lbs)

Force	=	Torque	X	Slope
lbs	=	in-lb	x	6.4
lbs	=	ft-lbs	x	76.3

Torque (ft-lb)	Force (lbs)
0	0
10	763
20	1525
30	2288
40	3051
50	3814
60	4576
70	5339
80	6102
90	6864
95	7246
100	7627
105	8008
110	8390
115	8771
118	9000

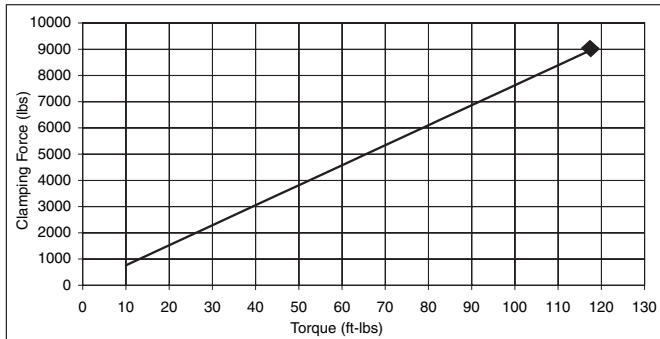

Note: **◆** Maximum Recommended Torque. Actual results may vary.

Kilo Newtons (kN)

Force	=	Torque	X	Slope
N	=	N-m	x	250
kN	=	N-m	x	0.25

Torque (N-m)	Force (kN)
0	0.0
10	2.5
20	5.0
30	7.5
40	10.0
50	12.5
60	15.0
70	17.5
80	20.0
90	22.5
100	25.0
110	27.5
120	30.0
130	32.5
140	35.0
150	37.5
160	40.0

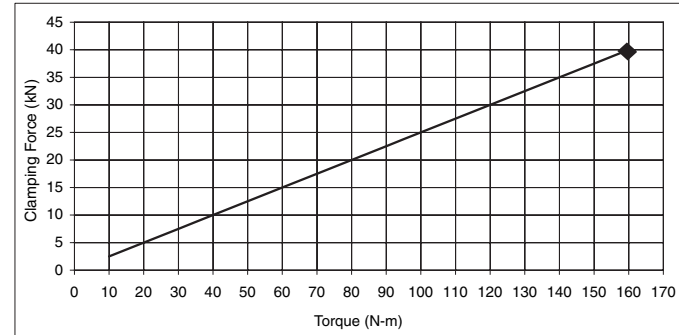

Note: **◆** Maximum Recommended Torque. Actual results may vary.

Notes

CHICK WORKHOLDING SOLUTIONS, INC.
 500 Keystone Drive • Warrendale, PA 15086 USA
 Phone: (724) 772-1644 • Fax: (724) 772-1633
www.ChickWorkholding.com