

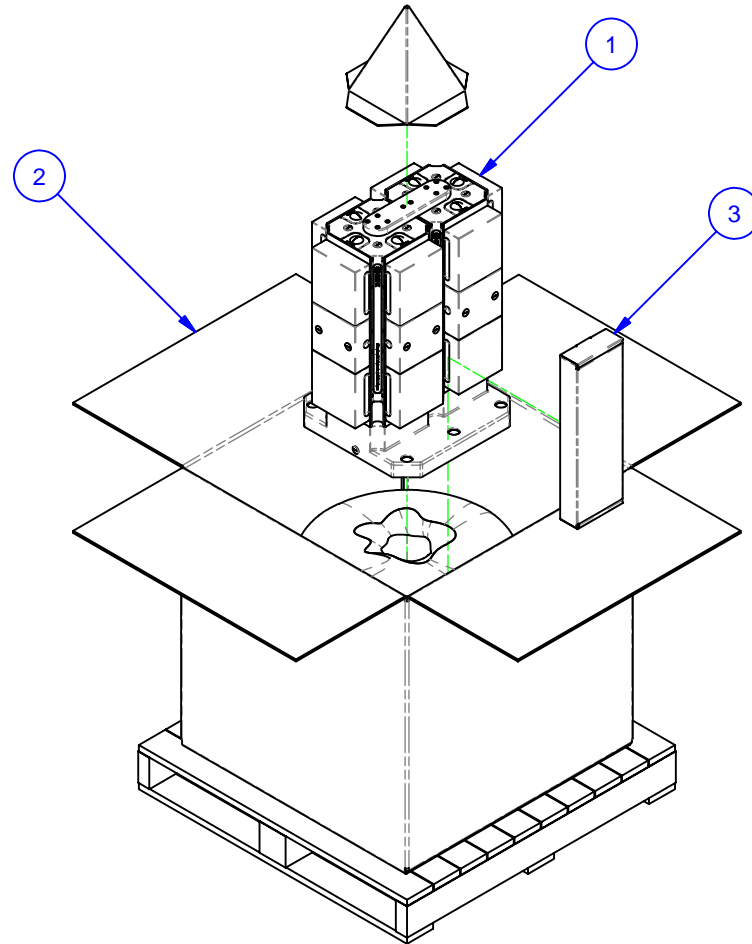

PARTS LIST						
No	QTY	PN	ITEM	TYPE	FAM	STYLE
1	1	188-1-10018	MULTI-LOK ASSEMBLY	JIS400mm PALLET	5ML1550-41-12	400 SQ BASE X 610 TALL
2	1	185-0-10005	PACKAGING	SHIPPING CONTAINER	HMC WORK PKG.	36x36x30 [M12 W/8" BOLTS]
3	1	185-0-10002	KIT	TOOLS	5ML15-41	STANDARD
4	1	058-2-10076	KIT	BASEPLATE MOUNTING	M16 TAPPED HOLE	(6) M16 X 40 SHCS
5	1	058-2-10021	KIT	BP EDGE LOCATING	5 & M	(3) M16 X 30 SHCS
6	1	058-2-10019	KIT	BASEPLATE PILOT	5 & M	STANDARD 50mm



MATERIAL: NA	UNSPECIFIED TOLERANCES: X ±0.2 X.X ±0.1 X.XX ±0.05 ANGLES ±0.5° ALL DIMENSIONS ARE MILLIMETERS.	 (800) 332-4425 (724) 772-1644 www.ChickWorkholding.com	ITEM: WORK PKG - HMC						
HARDNESS: NA			TYPE: KITAMURA HX-400_M-E						
COATING: NA			FAM: 5ML1550-41-12						
WEIGHT: 224900 g			STYLE: 400 SQ BASE X 610 TALL						
COMMENTS:			<table border="1"> <tr> <td>BCE</td> <td>1 OF 4</td> <td>5HP-KITA-00128</td> <td>REV A</td> </tr> <tr> <td colspan="2">6/4/2008</td> <td colspan="2"></td> </tr> </table>	BCE	1 OF 4	5HP-KITA-00128	REV A	6/4/2008	
BCE	1 OF 4	5HP-KITA-00128	REV A						
6/4/2008									

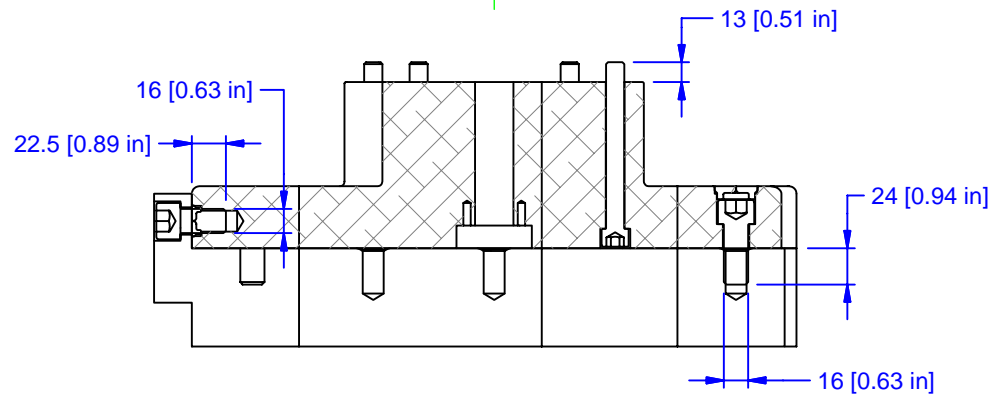
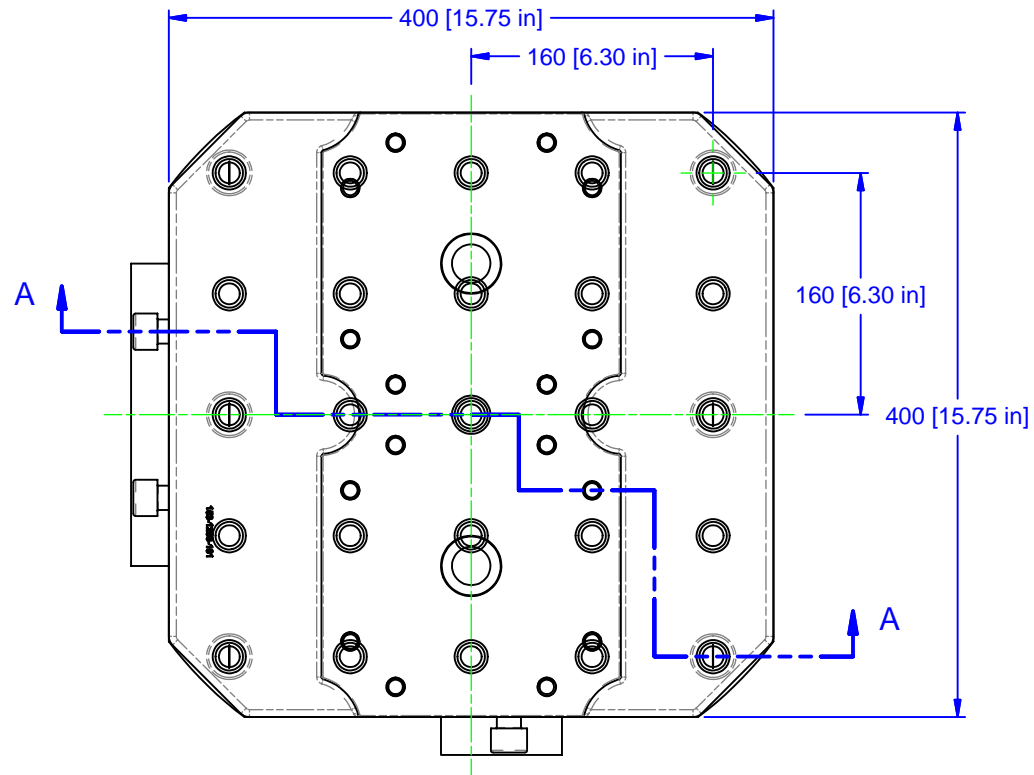

SECTION A-A

MATERIAL:	NA
HARDNESS:	NA
COATING:	NA
WEIGHT:	224900 g
COMMENTS:	

UNSPECIFIED TOLERANCES:	
X	±0.2
X.X	±0.1
X.XX	±0.05
ANGLES	±0.5°
ALL DIMENSIONS ARE MILLIMETERS.	

 (800) 332-4425
 (724) 772-1644
www.ChickWorkholding.com

UNSPECIFIED EDGES: BREAK 0.3 TO 0.8
 UNSPECIFIED FILLETS: RADIUS 0.3 MAX

ITEM:	WORK PKG - HMC		
TYPE:	KITAMURA HX-400_M-E		
FAM:	5ML1550-41-12		
STYLE:	400 SQ BASE X 610 TALL		
BCE	2 OF 4	5HP-KITA-00128	REV A
6/4/2008			

Ø610 [24.02 in]
MAXIMUM
WORKPIECE
SWING

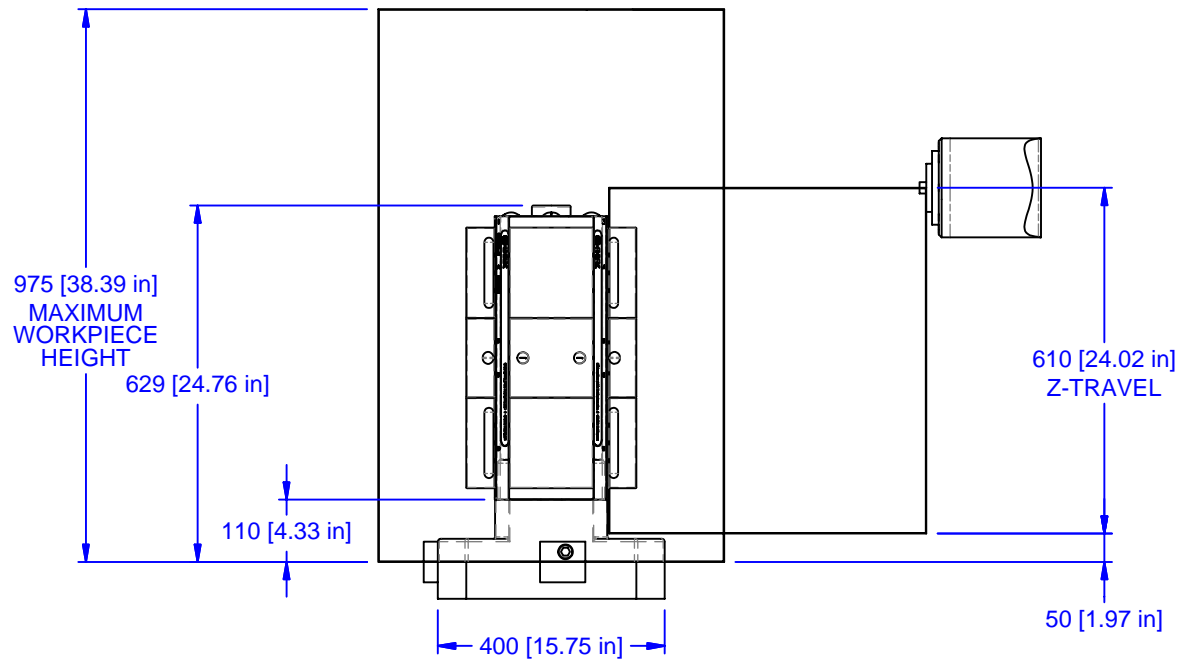
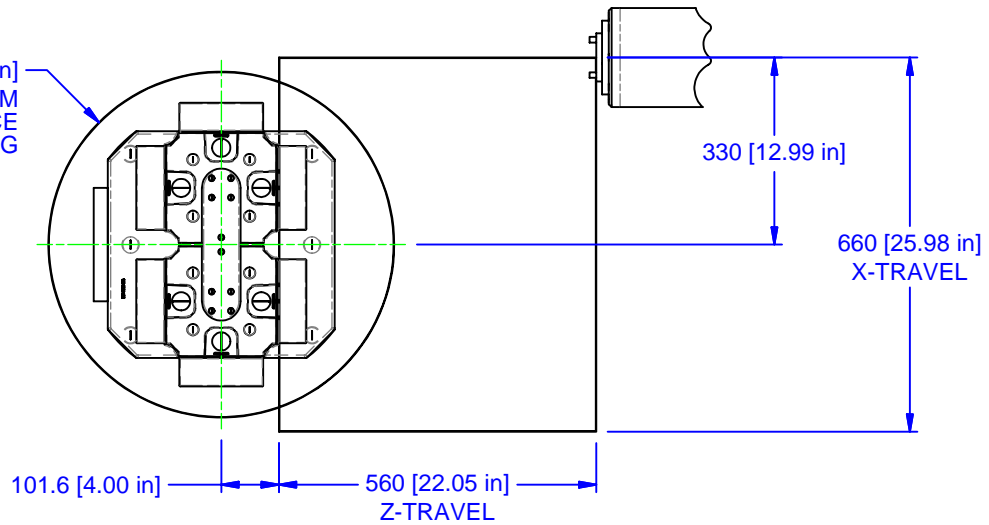

MATERIAL:	NA
HARDNESS:	NA
COATING:	NA
WEIGHT:	224900 g
COMMENTS:	

UNSPECIFIED TOLERANCES:
 X ±0.2
 X.X ±0.1
 X.XX ±0.05
 ANGLES ±0.5°
 ALL DIMENSIONS ARE MILLIMETERS.

CHICK (800) 332-4425
 (724) 772-1644
www.ChickWorkholding.com
 UNSPECIFIED EDGES: BREAK 0.3 TO 0.8
 UNSPECIFIED FILLETS: RADIUS 0.3 MAX

ITEM:	WORK PKG - HMC		
TYPE:	KITAMURA HX-400_M-E		
FAM:	5ML1550-41-12		
STYLE:	400 SQ BASE X 610 TALL		
BCE	3 OF 4	5HP-KITA-00128	REV
6/4/2008			A

2x M16x2 ∇ 30
 \perp \varnothing 20 ∇ 6.5

55 [2.17 in]

55 [2.17 in]

18 [0.71 in]

41 [1.61 in]

110 [4.33 in]

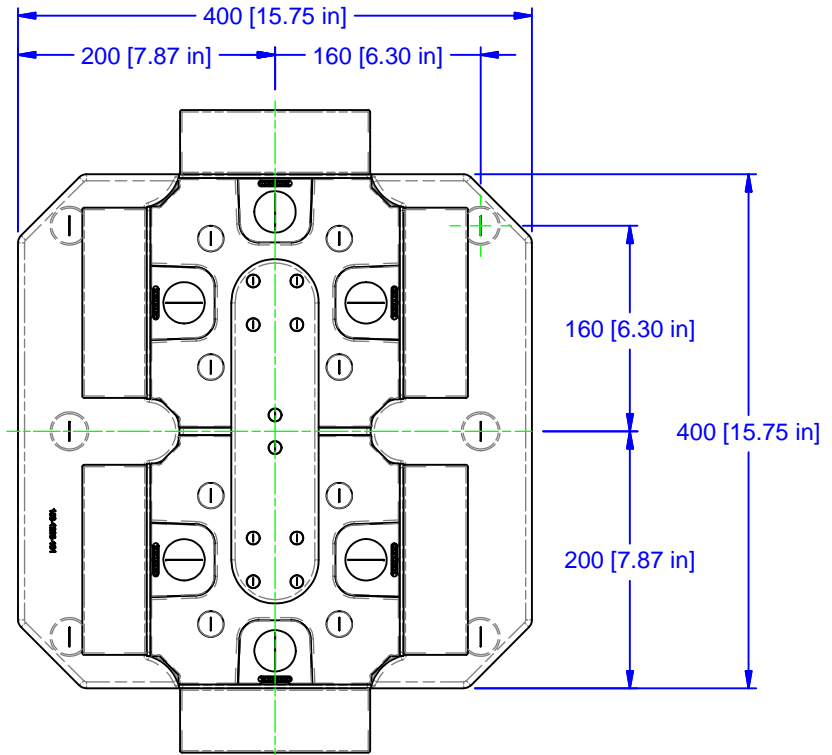

25 [0.98 in]

M16x2 ∇ 30
 \perp \varnothing 20 ∇ 6.5

18 [0.71 in]

6x
M16 SHCS

MATERIAL:	NA
HARDNESS:	NA
COATING:	NA
WEIGHT:	224900 g
COMMENTS:	

UNSPECIFIED TOLERANCES:
X \pm 0.2
X.X \pm 0.1
X.XX \pm 0.05
ANGLES \pm 0.5°
ALL DIMENSIONS ARE MILLIMETERS.

CHICK (800) 332-4425
(724) 772-1644
www.ChickWorkholding.com

UNSPECIFIED EDGES: BREAK 0.3 TO 0.8
UNSPECIFIED FILLETS: RADIUS 0.3 MAX

ITEM:	WORK PKG - HMC		
TYPE:	KITAMURA HX-400_M-E		
FAM:	5ML1550-41-12		
STYLE:	400 SQ BASE X 610 TALL		
BCE	4 OF 4	5HP-KITA-00128	REV
6/4/2008			A