

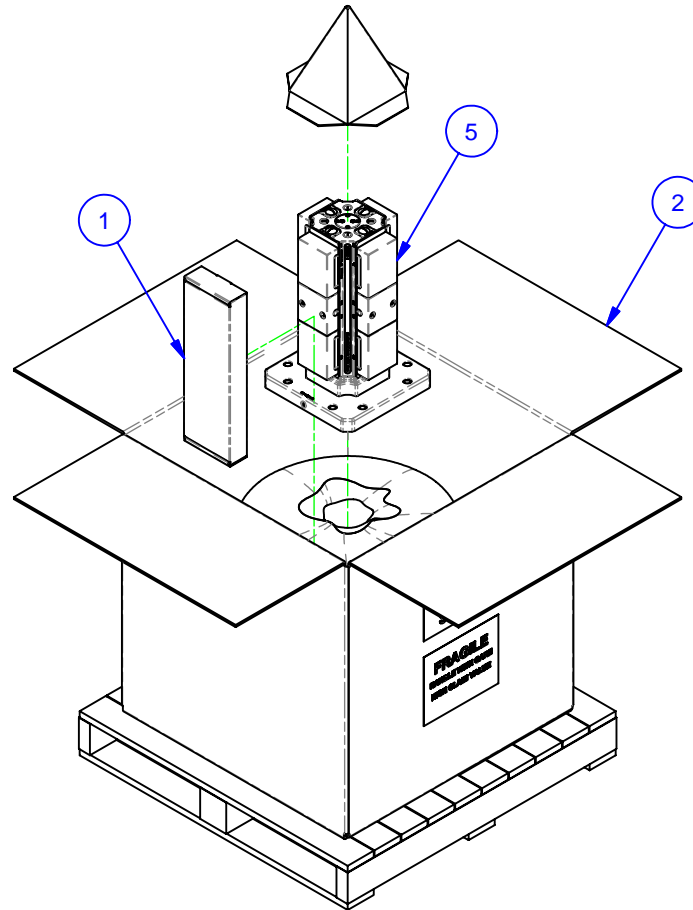

PARTS LIST						
No	QTY	PN	ITEM	TYPE	FAM	STYLE
1	1	185-0-10003	KIT	TOOLS	5ML10-41	STANDARD
2	1	185-0-10005	PACKAGING	SHIPPING CONTAINER	HMC WORK PKG.	36x36x30 [M12 W/8" BOLTS]
3	1	185-2-10005	KIT	PP TO PALLET - MOD BP	S5-41	300mm INCH
4	1	185-2-10018	KIT	PILOT	MODULAR BASEPLATE	STANDARD 1"
5	1	186-1-10241	MULTI-LOK ASSEMBLY	300mm INCH PALLET	5ML1040-41	45mm TALL RISER



MATERIAL: NA	UNSPECIFIED TOLERANCES: X ±0.2 X.X ±0.1 X.XX ±0.05 ANGLES ±0.5° ALL DIMENSIONS ARE MILLIMETERS.	 (800) 332-4425 (724) 772-1644 www.ChickWorkholding.com	ITEM: WORK PKG - HMC
HARDNESS: NA			TYPE: MATSUURA MAM-500HF_I-(C)(E)
COATING: NA			FAM: 5ML1040-41
WEIGHT: 81490 g			STYLE: 300 SQ BASE X 480 TALL
COMMENTS:			TDD 1 OF 4 5HP-MATS-00037 REV A
			2/3/2010

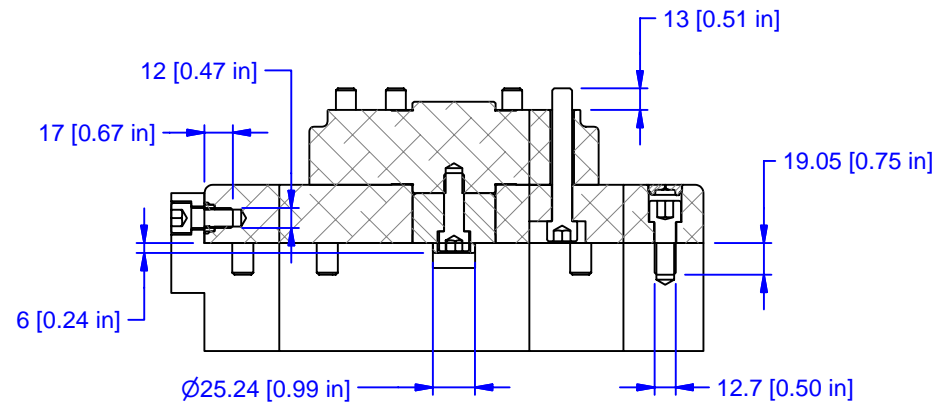
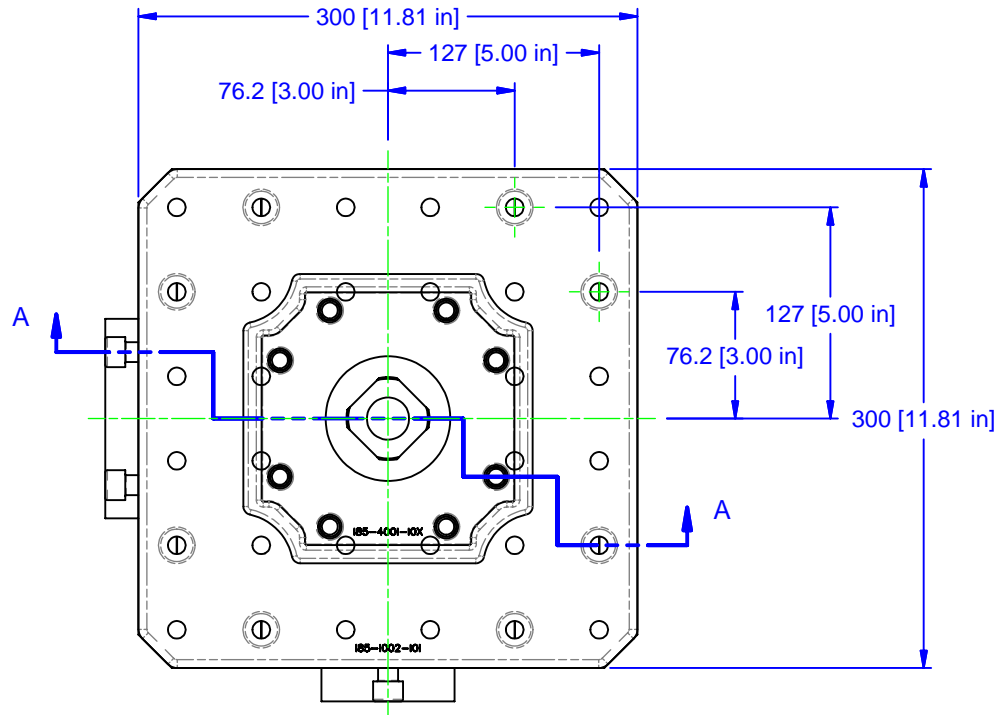

SECTION A-A

MATERIAL: NA
HARDNESS: NA
COATING: NA
WEIGHT: 81490 g
COMMENTS:

UNSPECIFIED TOLERANCES:
 X ±0.2
 X.X ±0.1
 X.XX ±0.05
 ANGLES ±0.5°
 ALL DIMENSIONS ARE MILLIMETERS.

CHICK (800) 332-4425
 (724) 772-1644
www.ChickWorkholding.com
 UNSPECIFIED EDGES: BREAK 0.3 TO 0.8
 UNSPECIFIED FILLETS: RADIUS 0.3 MAX

ITEM: WORK PKG - HMC		REV A
TYPE: MATSUURA MAM-500HF_I-(C)(E)		
FAM: 5ML1040-41		5HP-MATS-00037
STYLE: 300 SQ BASE X 480 TALL		
TDD	2 OF 4	
2/3/2010		

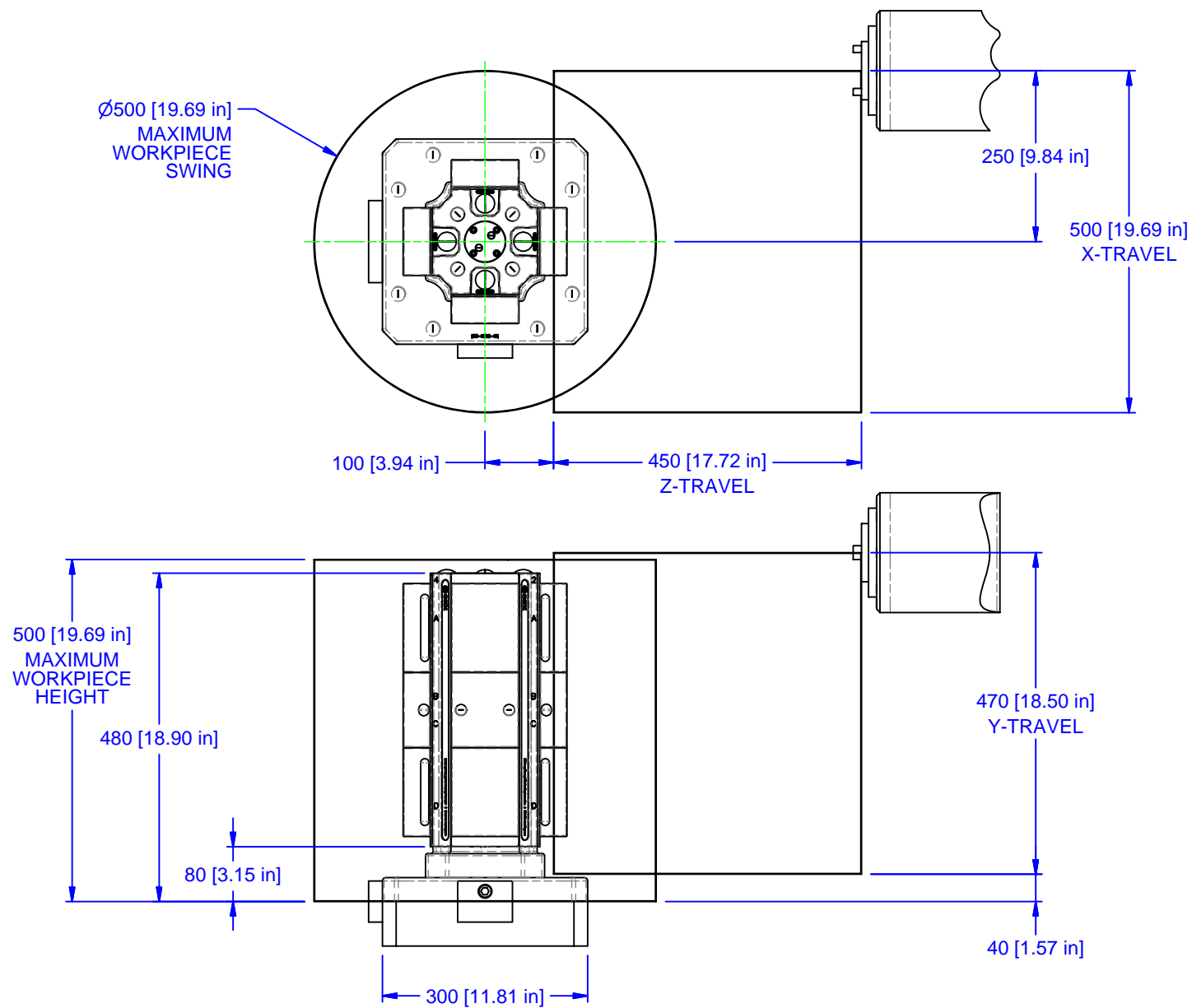

MATERIAL: NA	UNSPECIFIED TOLERANCES: X ± 0.2 X.X ± 0.1 X.XX ± 0.05 ANGLES $\pm 0.5^\circ$ ALL DIMENSIONS ARE MILLIMETERS.	 (800) 332-4425 (724) 772-1644 www.ChickWorkholding.com	ITEM: WORK PKG - HMC	<table border="1"> <tr> <td>TDD</td> <td>3 OF 4</td> <td rowspan="3">SHP-MATS-00037</td> <td rowspan="3">REV A</td> </tr> <tr> <td colspan="2">2/3/2010</td> </tr> <tr> <td>TDD</td> <td>2/3/2010</td> </tr> </table>	TDD	3 OF 4	SHP-MATS-00037	REV A	2/3/2010		TDD	2/3/2010
TDD			3 OF 4		SHP-MATS-00037	REV A						
2/3/2010												
TDD			2/3/2010									
HARDNESS: NA			TYPE: MATSUURA MAM-500HF_I-(C)(E)									
COATING: NA	FAM: 5ML1040-41											
WEIGHT: N/A	STYLE: 300 SQ BASE X 480 TALL											
COMMENTS:	UNSPECIFIED EDGES: BREAK 0.3 TO 0.8 UNSPECIFIED FILLETS: RADIUS 0.3 MAX											

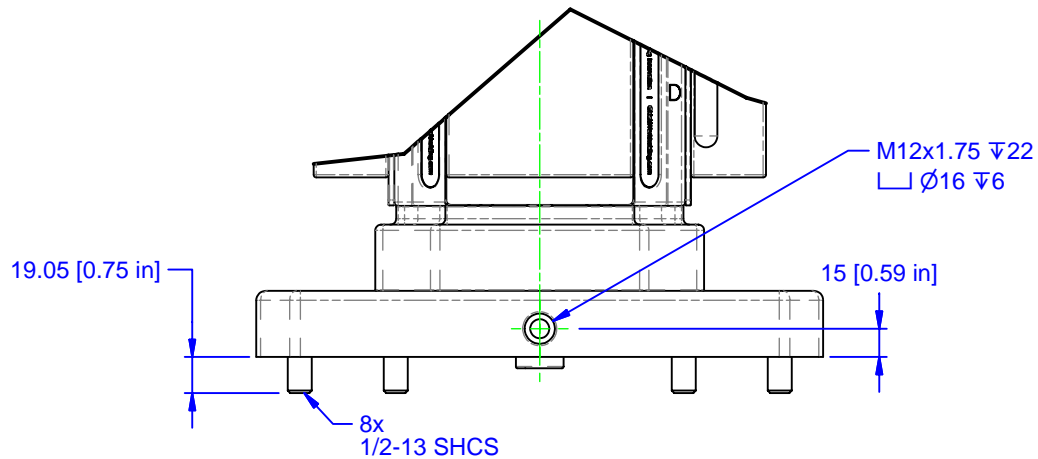
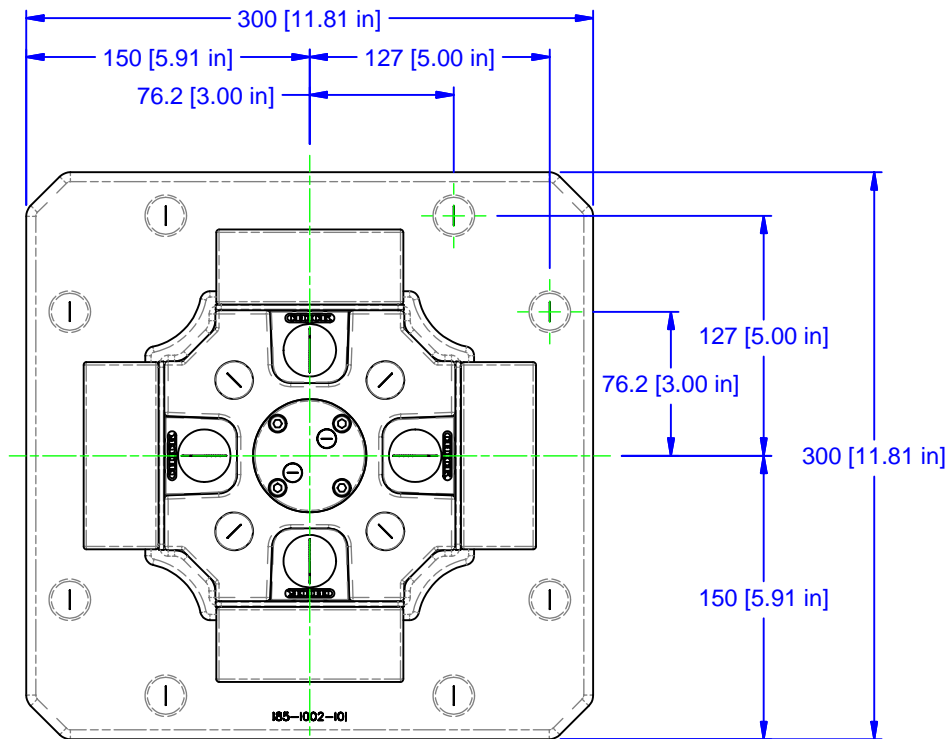
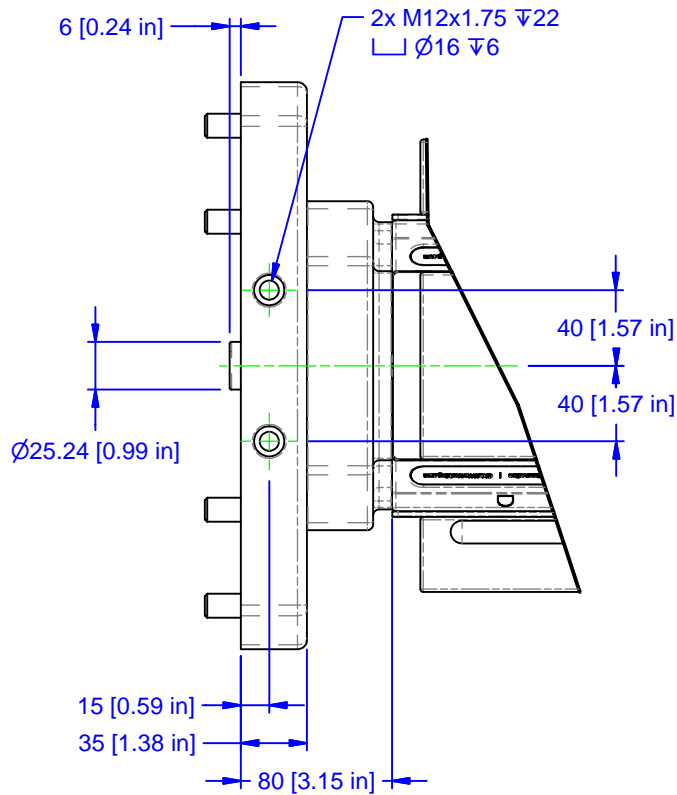

MATERIAL:	NA
HARDNESS:	NA
COATING:	NA
WEIGHT:	N/A
COMMENTS:	

UNSPECIFIED TOLERANCES:
 X \pm 0.2
 X.X \pm 0.1
 X.XX \pm 0.05
 ANGLES \pm 0.5°
 ALL DIMENSIONS ARE MILLIMETERS.

CHICK (800) 332-4425
 (724) 772-1644
www.ChickWorkholding.com
 UNSPECIFIED EDGES: BREAK 0.3 TO 0.8
 UNSPECIFIED FILLETS: RADIUS 0.3 MAX

ITEM: WORK PKG - HMC			
TYPE: MATSUURA MAM-500HF_I-(C)(E)			
FAM: 5ML1040-41			
STYLE: 300 SQ BASE X 480 TALL			
TDD	4 OF 4	5HP-MATS-00037	REV A
2/3/2010			