

5HP-MATS-00064

This workholding package is designed for your MATSUURA H+300 (Metric) machining center.



Notes

CHICK WORKHOLDING SOLUTIONS, INC
500 Keystone Drive • Warrendale, PA 15086 USA
Phone: (724) 772-1644 • Fax: (724) 772-1633
Toll Free: (800) 33-CHICK • (800) 332-4425
www.ChickWorkholding.com

5HP-MATS-00064

This workholding package is designed for your MATSUURA H+300 (Metric) machining center.

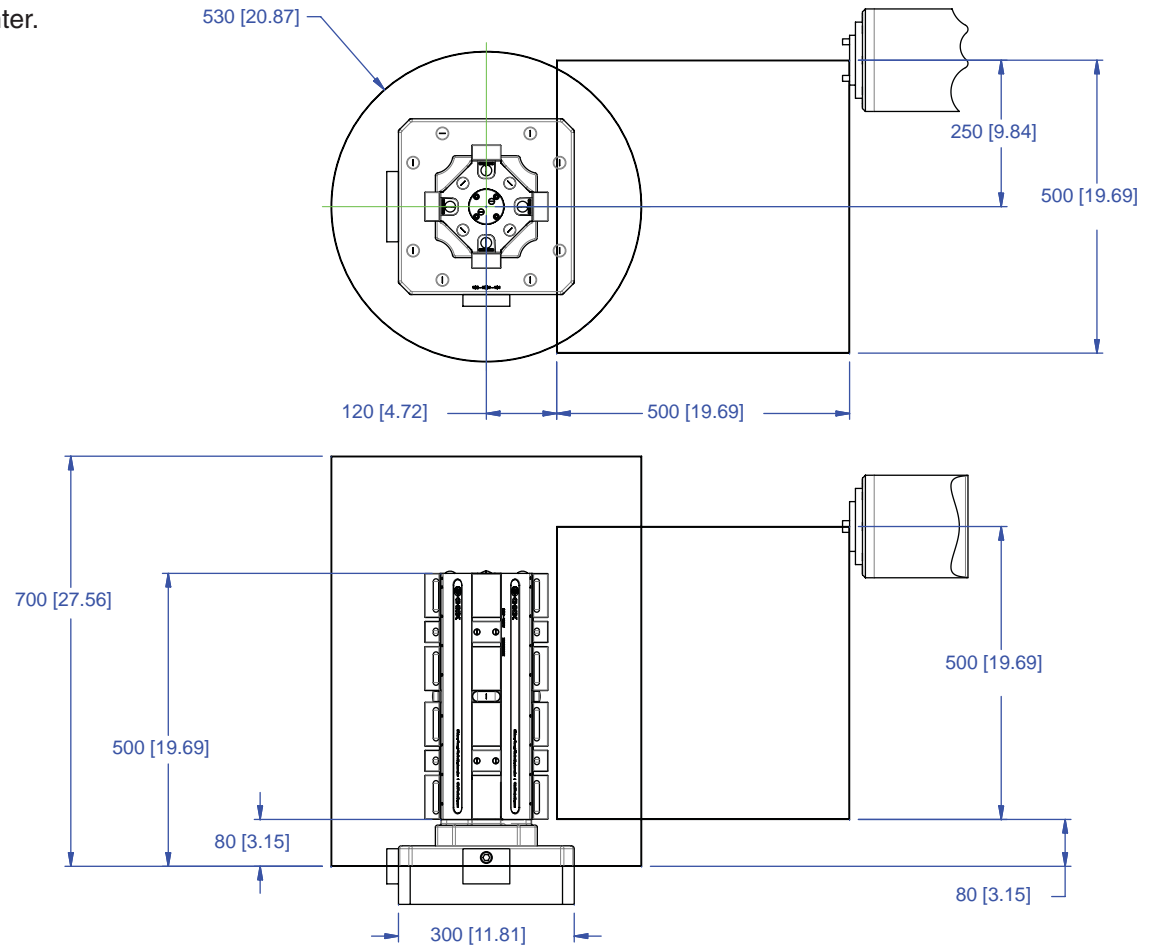

Notes

Machine travel may be limited by mechanical interference and/or machine safety zones. Please consult your machine's operating instructions for more information.

All dimensions are MM [IN]

CHICK WORKHOLDING SOLUTIONS, INC
 500 Keystone Drive • Warrendale, PA 15086 USA
 Phone: (724) 772-1644 • Fax: (724) 772-1633
 Toll Free: (800) 33-CHICK • (800) 332-4425
www.ChickWorkholding.com

5HP-MATS-00064

This workholding package is designed for your MATSUURA H+300 (Metric) machining center.

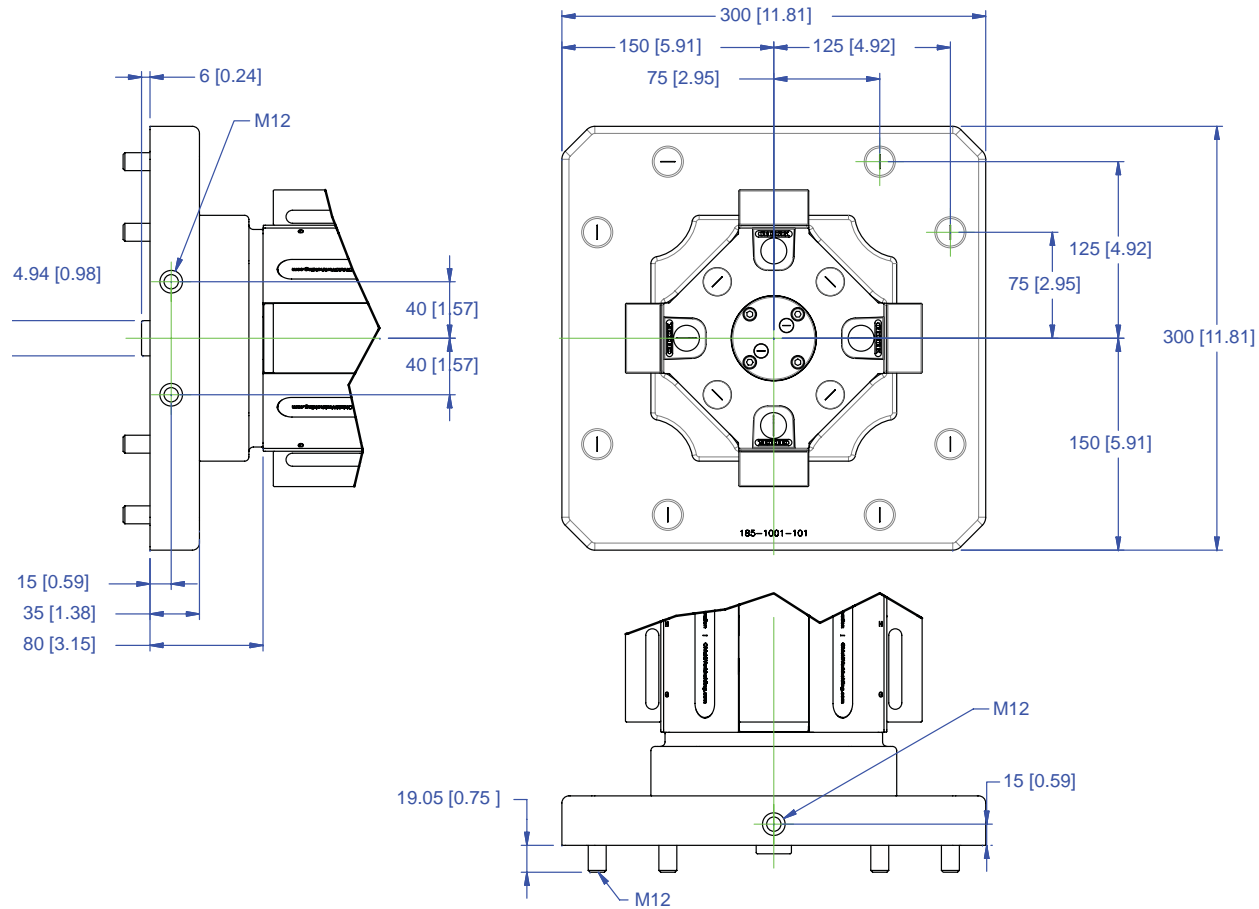

Notes

All dimensions are MM [IN]

CHICK WORKHOLDING SOLUTIONS, INC
 500 Keystone Drive • Warrendale, PA 15086 USA
 Phone: (724) 772-1644 • Fax: (724) 772-1633
 Toll Free: (800) 33-CHICK • (800) 332-4425
www.ChickWorkholding.com

Batch Production

Machinable accessories are the optimal solution for batch production. They offer QwikChange™ and accurate repeat set ups to optimize the productivity of the machine center.

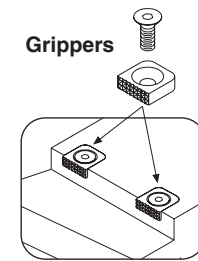
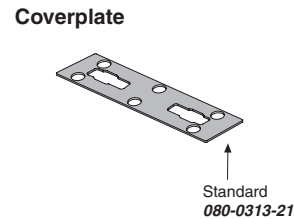
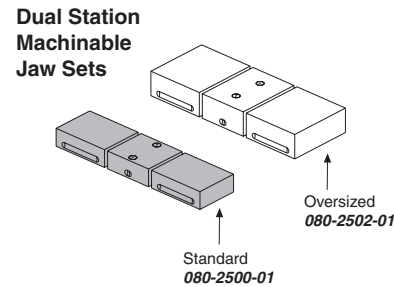
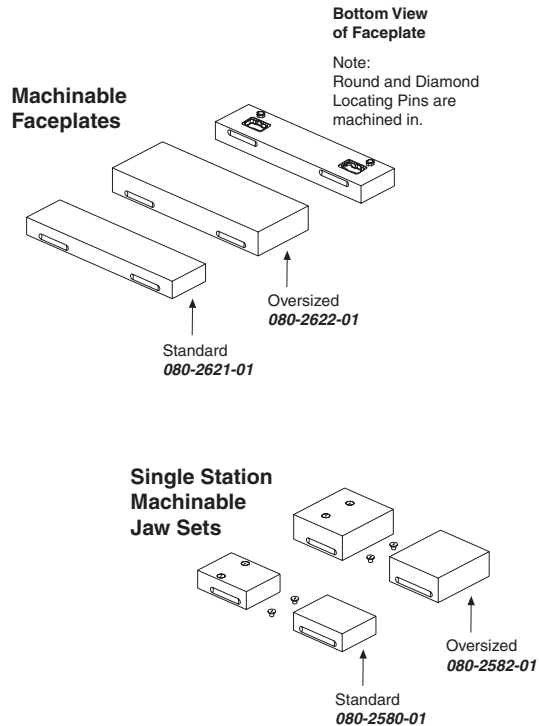

Gripper #3
Plain **005-2531**
Serrated **005-2532**
(L-9mm x W-9mm x T-8mm)

Gripper #4
Plain **005-2541**
Serrated **005-2542**
(L-12mm x W-12mm x T-4.6mm)

Gripper #5
Plain **005-2551**
Serrated **005-2552**
(L-15mm x W-15mm x T-5mm)

Gripper #6
Plain **005-2561**
Serrated **005-2562**
(L-19mm x W-19mm x T-6mm)

Notes

Grey item is included with a standard system

CHICK WORKHOLDING SOLUTIONS, INC
500 Keystone Drive • Warrendale, PA 15086 USA
Phone: (724) 772-1644 • Fax: (724) 772-1633
Toll Free: (800) 33-CHICK • (800) 332-4425
www.ChickWorkholding.com

Dedicated Fixturing

Machinable Faceplates provide QwikChange™ dedicated fixturing and are optimal for awkward or hard to hold parts. A mini pallet changer can be created by utilizing two Faceplates in tandem.

Machinable Faceplates

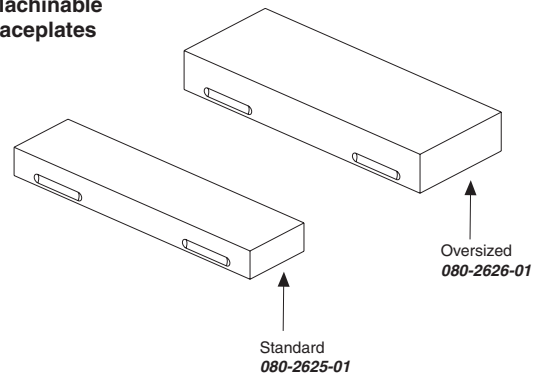

Notes

CHICK WORKHOLDING SOLUTIONS, INC
500 Keystone Drive • Warrendale, PA 15086 USA
Phone: (724) 772-1644 • Fax: (724) 772-1633
Toll Free: (800) 33-CHICK • (800) 332-4425
www.ChickWorkholding.com

**QwikChange Machinable
Dual Station Jaws**

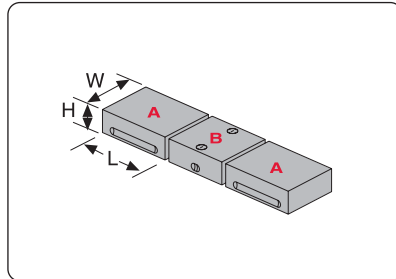

Individual Dual Station Jaws

Standard

A Moveable Jaw **080-2511-01**
(W49mm, H25mm, L75mm)

B Fixed Jaw **080-2551-01**
(W49mm, H25mm, L36mm)

Oversized

A Moveable Jaw **080-2512-01**
(W80mm, H35mm, L75mm)

B Fixed Jaw **080-2522-01**
(W80mm, H35mm, L36mm)

**QwikChange Machinable
Single Station Jaws**

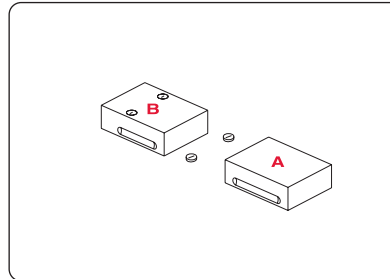

Individual Single Station Jaws

Standard

A Moveable Jaw **080-2511-01**
(W49mm, H25mm, L75mm)

B Fixed Jaw **080-2571-01**
(W49mm, H25mm, L75mm)

Oversized

A Moveable Jaw **080-2512-01**
(W80mm, H35mm, L75mm)

B Fixed Jaw **080-2575-01**
(W80mm, H35mm, L75mm)

Screws and Plugs

Dual Station

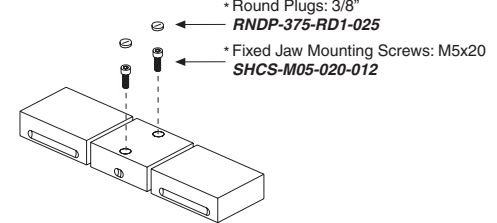

* Round Plugs: 3/8"
RNDP-375-RD1-025

* Fixed Jaw Mounting Screws: M5x20
SHCS-M05-020-012

Single Station

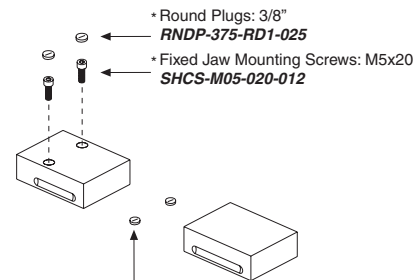

* Round Plugs: 3/8"
RNDP-375-RD1-025

* Fixed Jaw Mounting Screws: M5x20
SHCS-M05-020-012

* Round Plugs: 3/8"
RNDP-375-RD1-025

Notes

Grey or * item is included with a standard system

CHICK WORKHOLDING SOLUTIONS, INC
500 Keystone Drive • Warrendale, PA 15086 USA
Phone: (724) 772-1644 • Fax: (724) 772-1633
Toll Free: (800) 33-CHICK • (800) 332-4425
www.ChickWorkholding.com

Dual Station

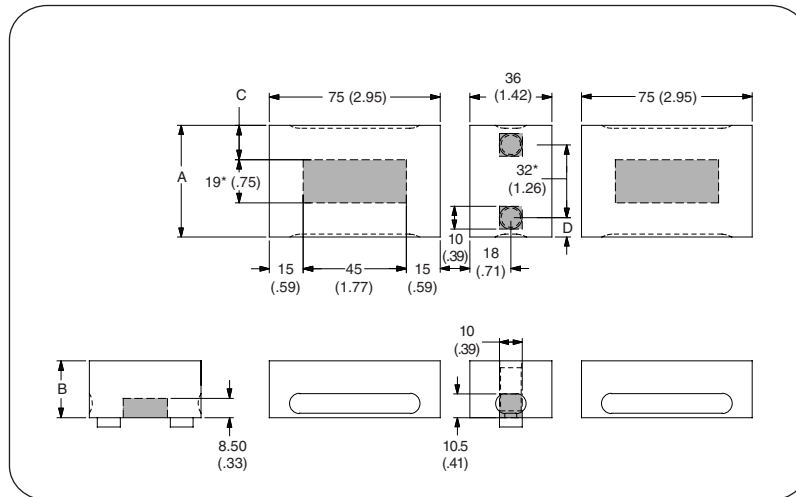

Item Number	Description	A	B	C	D
080-2500	Standard	49 (1.93)	25 (.98)	15 (.59)	8.5 (.33)
080-2502	Oversized	80 (3.15)	35 (1.38)	30.5 (1.20)	24 (.94)

Single Station

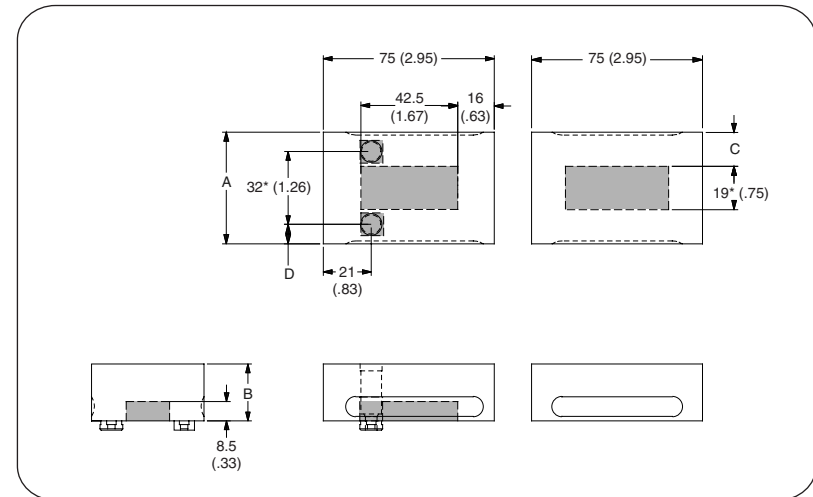

Item Number	Description	A	B	C	D
080-2580	Standard	49 (1.93)	25 (.98)	15 (.59)	8.5 (.33)
080-2582	Oversized	80 (3.15)	35 (1.38)	30.5 (1.20)	24 (.94)

Notes

Grey area indicates no cut zone
 All dimensions are MM [IN]
 Dimensions centered on the "A" dimension.

CHICK WORKHOLDING SOLUTIONS, INC
 500 Keystone Drive • Warrendale, PA 15086 USA
 Phone: (724) 772-1644 • Fax: (724) 772-1633
 Toll Free: (800) 33-CHICK • (800) 332-4425
www.ChickWorkholding.com

Dual Station

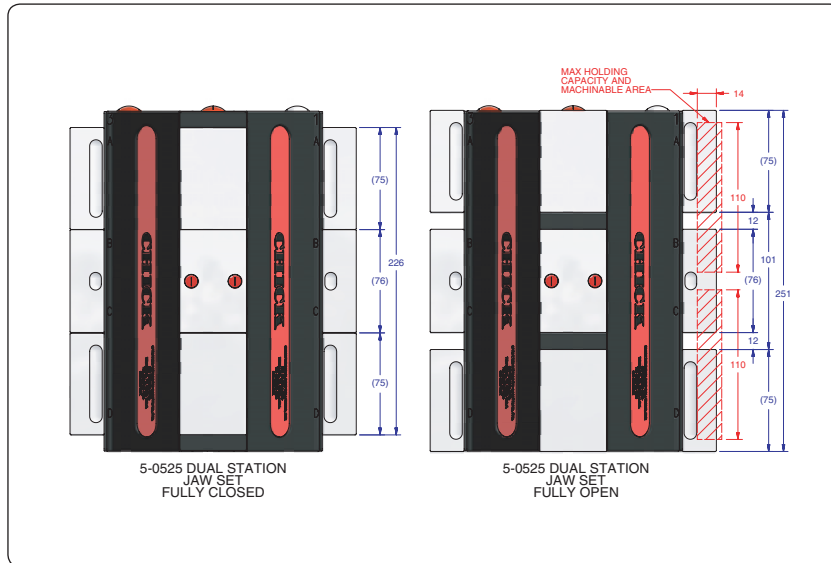

Single Station

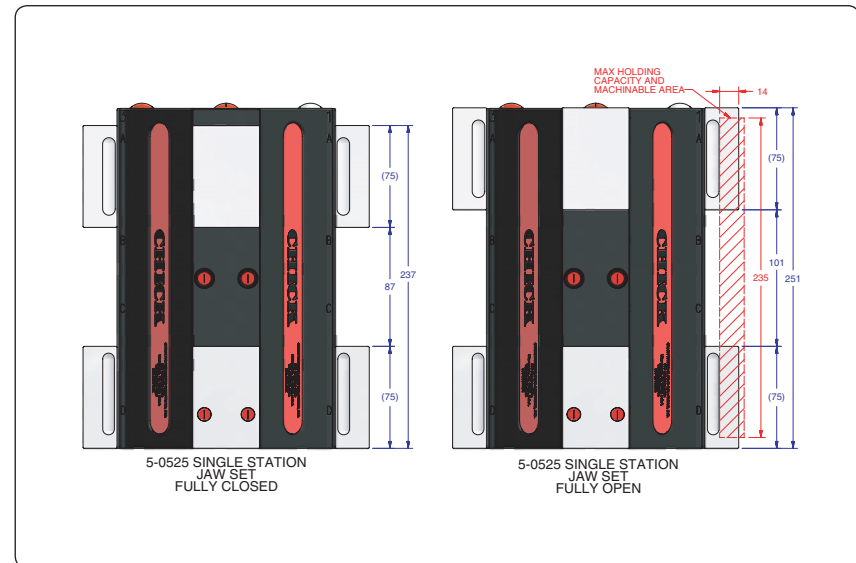

Item Number	Description	A	Jaw Width
080-2500	Standard	14 [0.57]	49 [1.93]
080-2506	Oversized	24 [0.96]	80 [3.15]

Item Number	Description	A	Jaw Width
080-2580	Standard	14 [0.57]	49 [1.93]
080-2582	Oversized	24 [0.96]	80 [3.15]

Notes

All dimensions are MM [IN]
 Additional closure is available with an Extended Travel Coverplate.
 Contact CHICK for details.

CHICK WORKHOLDING SOLUTIONS, INC
 500 Keystone Drive • Warrendale, PA 15086 USA
 Phone: (724) 772-1644 • Fax: (724) 772-1633
 Toll Free: (800) 33-CHICK • (800) 332-4425
www.ChickWorkholding.com

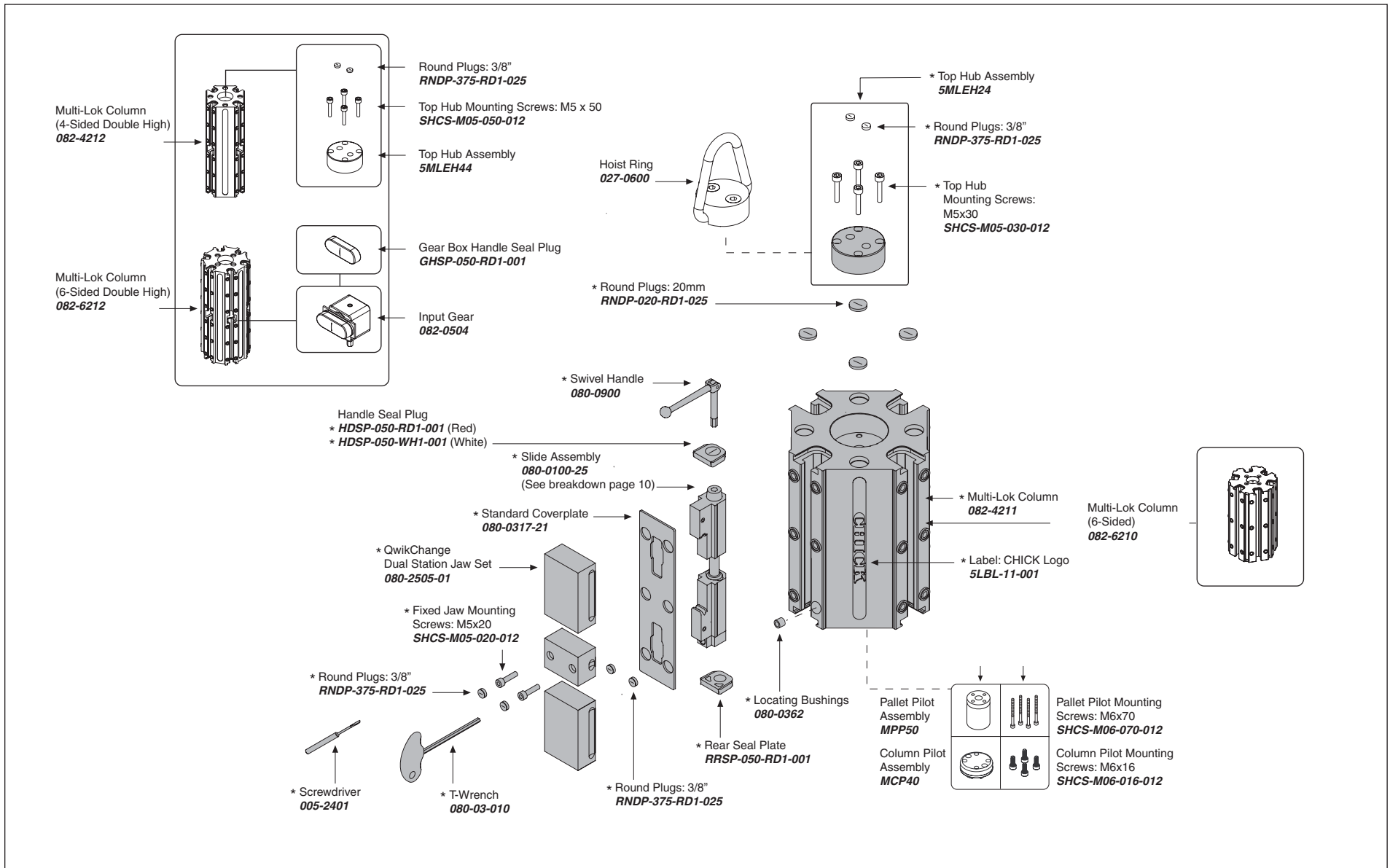

Notes

Grey items are included with a standard system
 For QwikChange™ Jaw accessories, see pages 4-6

CHICK WORKHOLDING SOLUTIONS, INC
 500 Keystone Drive • Warrendale, PA 15086 USA
 Phone: (724) 772-1644 • Fax: (724) 772-1633
 Toll Free: (800) 33-CHICK • (800) 332-4425
www.ChickWorkholding.com

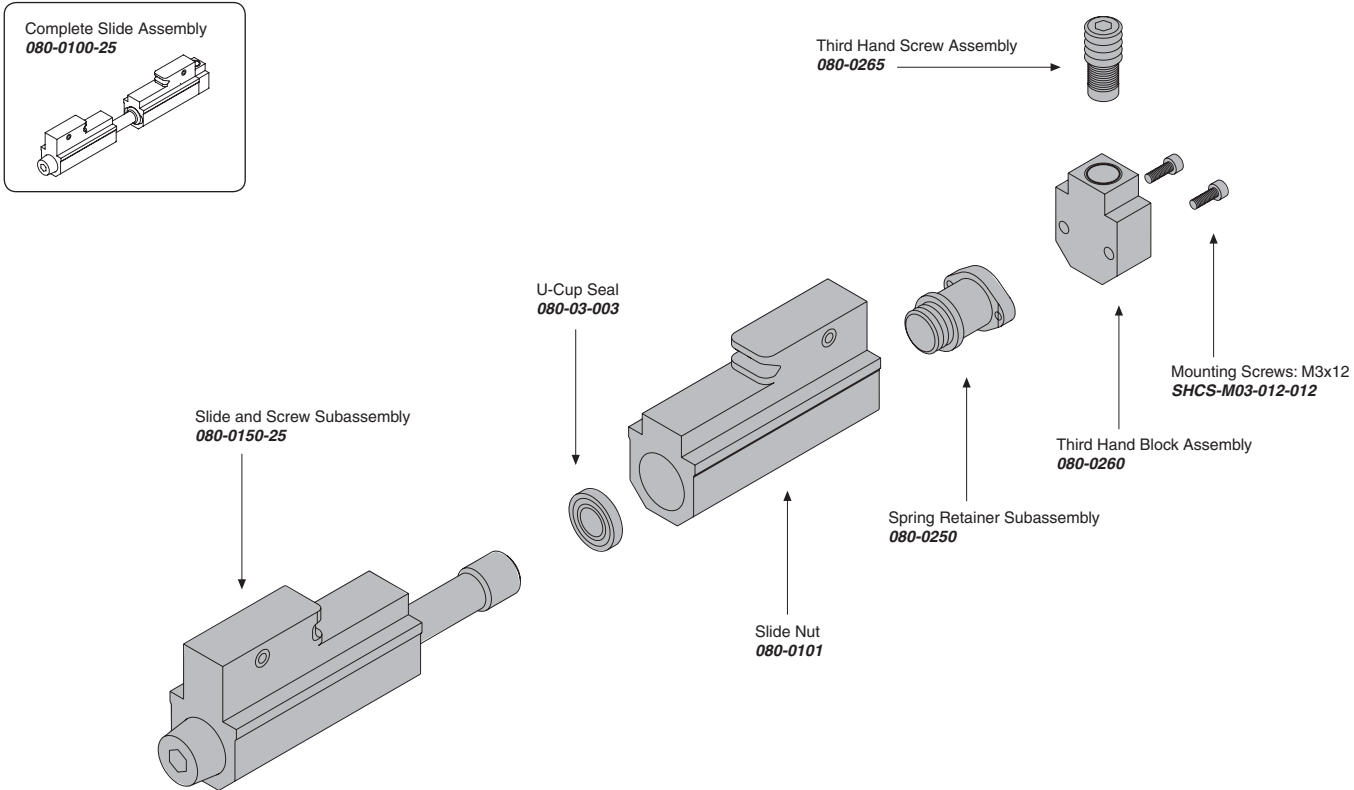

Notes

Grey items are included with a standard system

CHICK WORKHOLDING SOLUTIONS, INC
 500 Keystone Drive • Warrendale, PA 15086 USA
 Phone: (724) 772-1644 • Fax: (724) 772-1633
 Toll Free: (800) 33-CHICK • (800) 332-4425
www.ChickWorkholding.com

Pounds (lbs)

Force	=	Torque	X	Slope
lbs	=	in-lb	x	15
lbs	=	ft-lbs	x	180

Torque (ft-lb)	Force (lbs)
0	0
2	360
4	720
6	1080
8	1440
10	1800
12	2160
14	2520

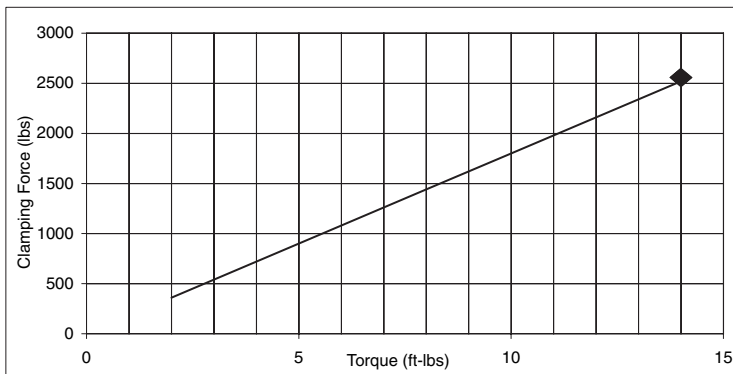

Note: ◆ Maximum Recommended Torque. Actual results may vary.

Kilo Newtons (kN)

Force	=	Torque	X	Slope
N	=	N-m	x	590
kN	=	N-m	x	0.59

Torque (N-m)	Force (kN)
0	0.0
4	2.4
8	4.7
12	7.1
14	8.2
18	10.6
19	11.2

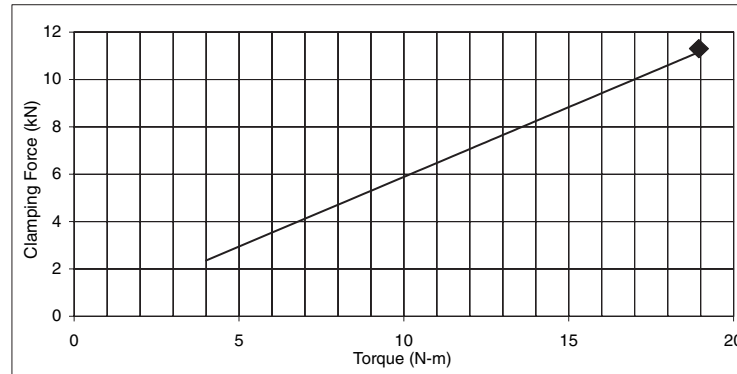

Note: ◆ Maximum Recommended Torque. Actual results may vary.

Notes

CHICK WORKHOLDING SOLUTIONS, INC
 500 Keystone Drive • Warrendale, PA 15086 USA
 Phone: (724) 772-1644 • Fax: (724) 772-1633
 Toll Free: (800) 33-CHICK • (800) 332-4425
www.ChickWorkholding.com