

THIS WORKHOLDING PACKAGE IS DESIGNED  
FOR HAAS HRT210 & HRT210SP ROTARY TABLES

(ROTARY TABLE NOT INCLUDED WITH PACKAGE)

		(800) 332-4425	
		(724) 772-1644	
<a href="http://www.ChickWorkholding.com">www.ChickWorkholding.com</a>			
PRODUCT INFORMATION PACKET (PIP) FOR WORKHOLDING PACKAGE <b>5RP-HAAS-00422</b>			
	1 OF 7	5RP-HAAS-00422	REV
2/12/2009		PIP	A

ALL COMPONENTS (EXCLUDING THE ROTARY TABLE)  
REQUIRED FOR COMPLETE ASSEMBLY ARE INCLUDED  
WITH THIS WORKHOLDING PACKAGE.

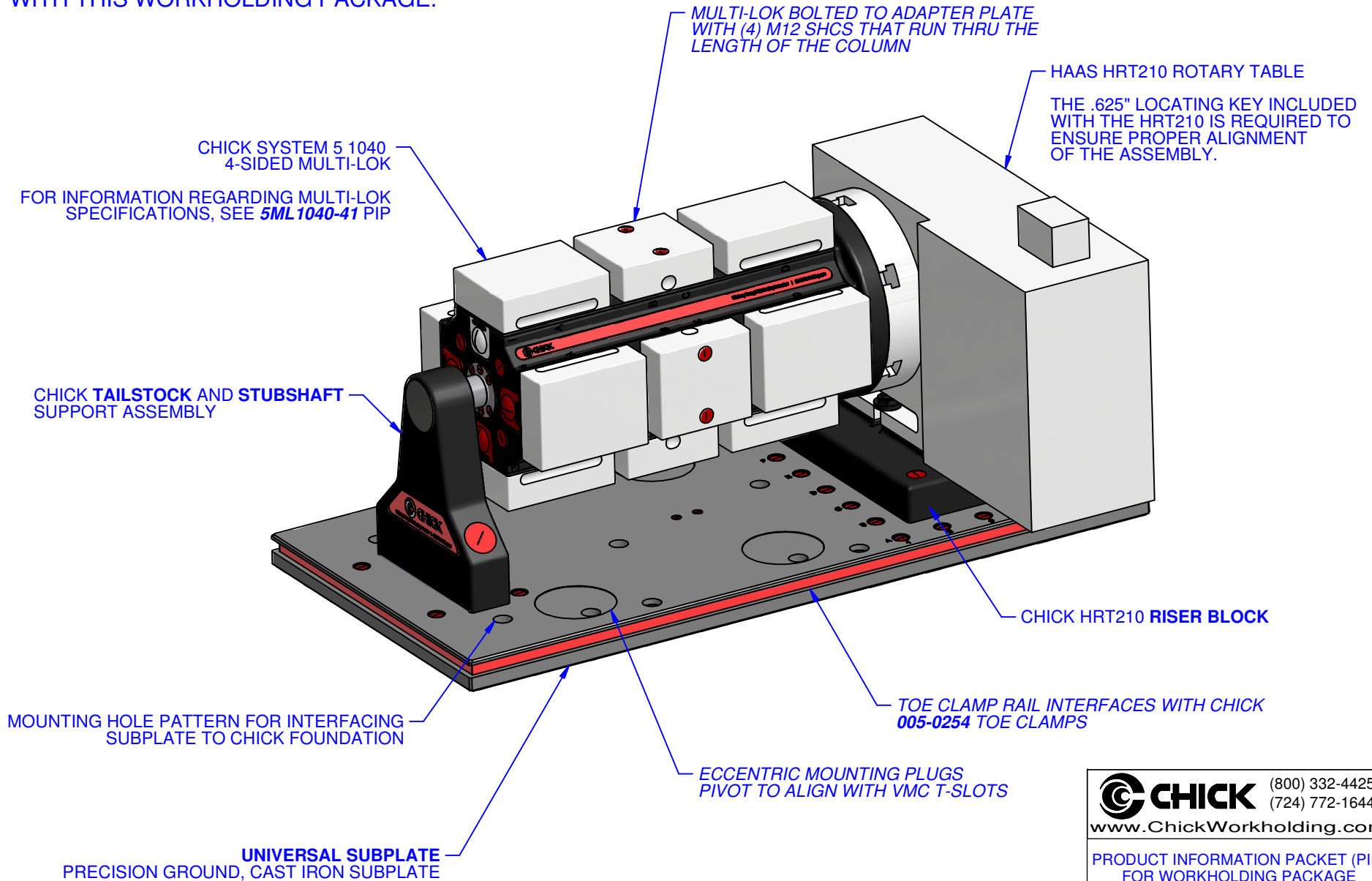



**CHICK** (800) 332-4425  
(724) 772-1644  
[www.ChickWorkholding.com](http://www.ChickWorkholding.com)

PRODUCT INFORMATION PACKET (PIP)  
FOR WORKHOLDING PACKAGE  
**5RP-HAAS-00422**

	2 OF 7	5RP-HAAS-00422	REV
2/12/2009		PIP	A

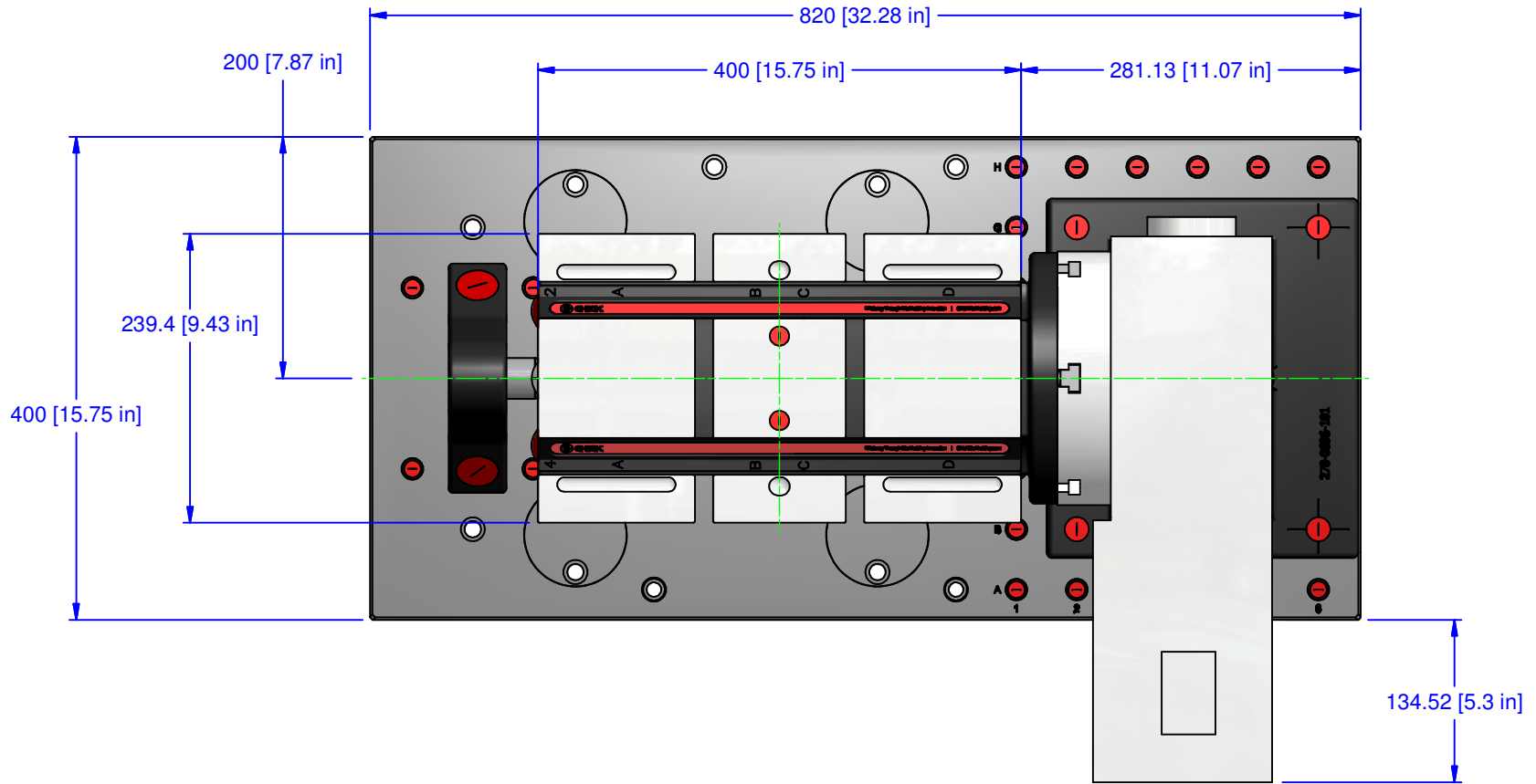
**DIMENSIONAL INFORMATION (TOP VIEW)**



		(800) 332-4425 (724) 772-1644
<a href="http://www.ChickWorkholding.com">www.ChickWorkholding.com</a>		
PRODUCT INFORMATION PACKET (PIP) FOR WORKHOLDING PACKAGE <b>5RP-HAAS-00422</b>		
3 OF 7 2/12/2009	5RP-HAAS-00422 PIP	REV A

**DIMENSIONAL INFORMATION (FRONT AND SIDE VIEW)**

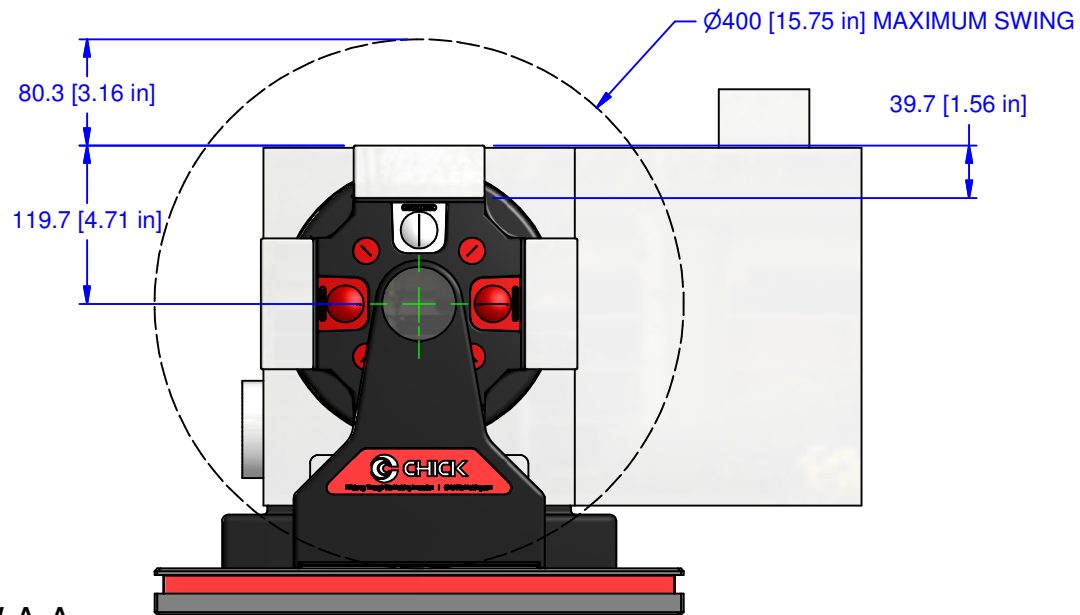
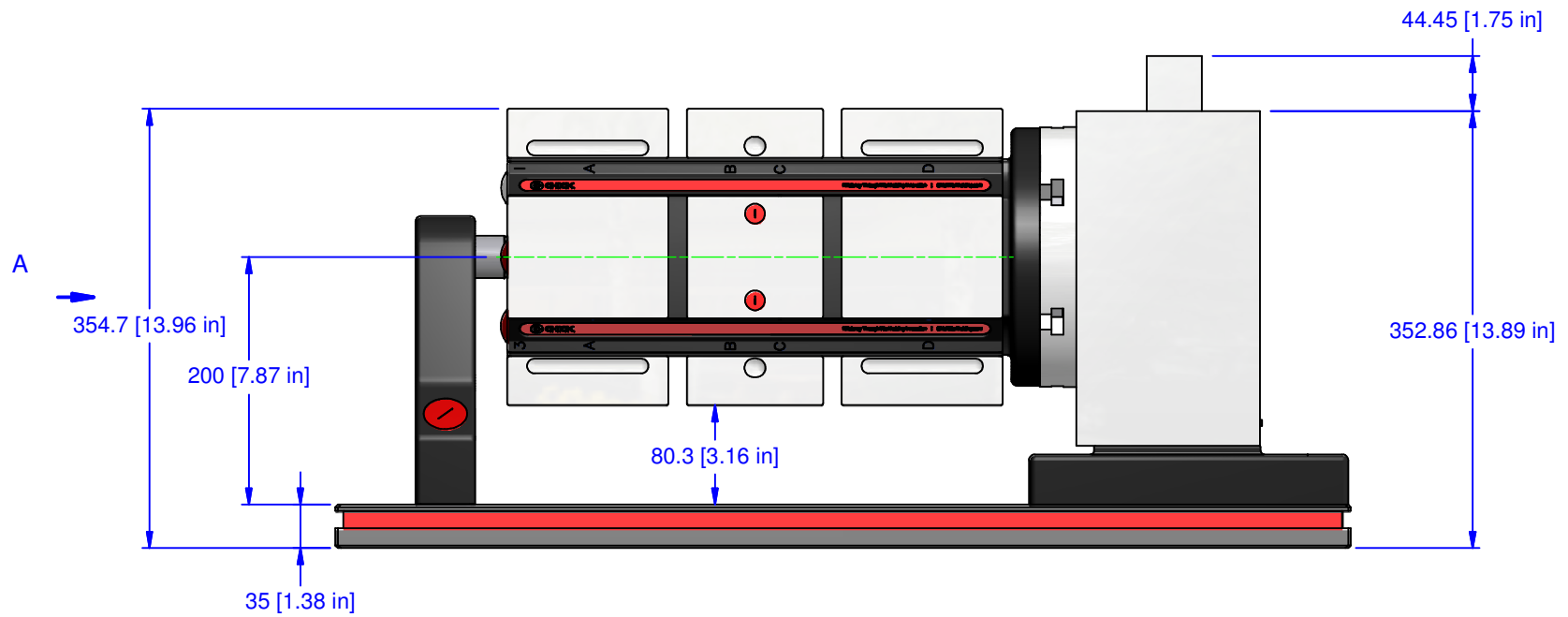

VIEW A-A

**CHICK** (800) 332-4425  
 (724) 772-1644  
[www.ChickWorkholding.com](http://www.ChickWorkholding.com)

PRODUCT INFORMATION PACKET (PIP)  
 FOR WORKHOLDING PACKAGE  
**5RP-HAAS-00422**

	4 OF 7	5RP-HAAS-00422	REV
2/12/2009		PIP	A

ECCENTRIC MOUNTING PLUGS (4 PLACES) PIVOT  
360 DEGREES TO ALIGN WITH VMC TABLE'S T-SLOTS  
1/2-13 OR M12 SHCS MAY BE USED

ROTARY TABLE MOUNTING GRID  
(48 HOLES)  
FOR GRID INFORMATION, SEE CHICK  
FOUNDATION SPECS

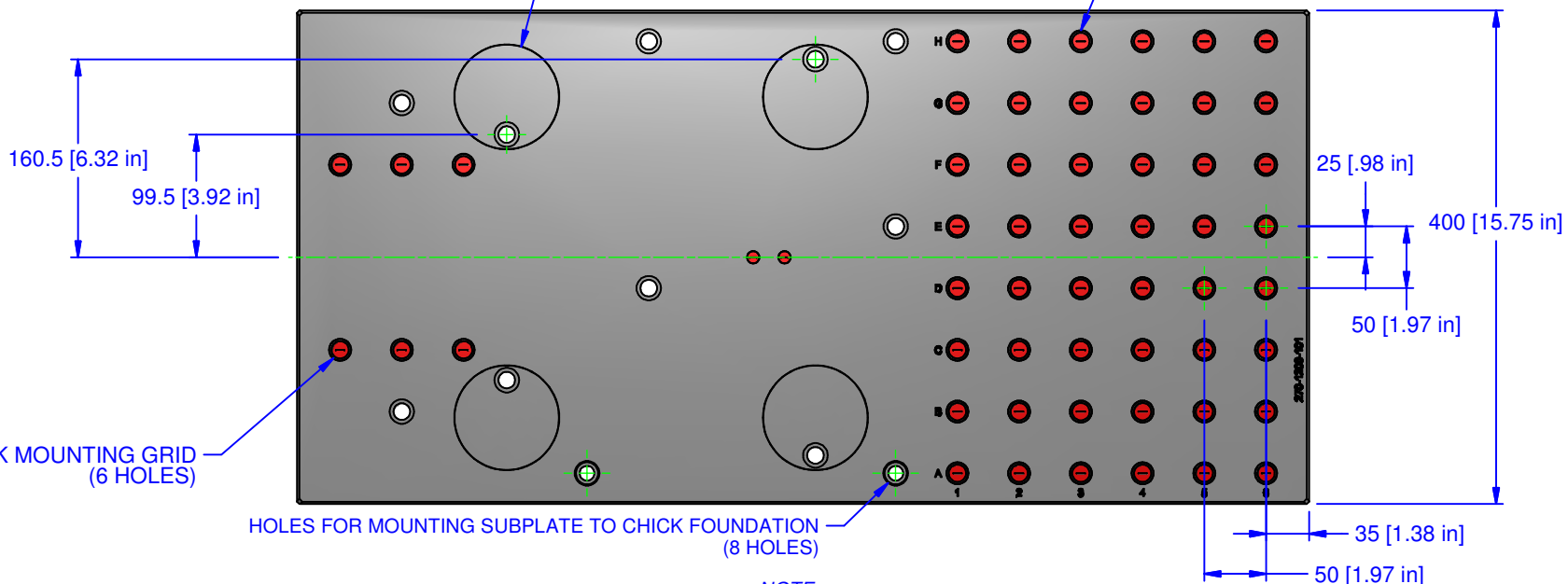

NOTE:  
THE (2) HOLES MARKED WITH CROSSHAIRS HAVE ACCURATE  
THROUGH FEATURES AND PROVIDE POSITIVE LOCATION WHEN  
USED WITH CHICK'S FOUNDATION LOCATING BOLTS (050-0002)

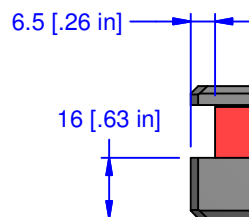
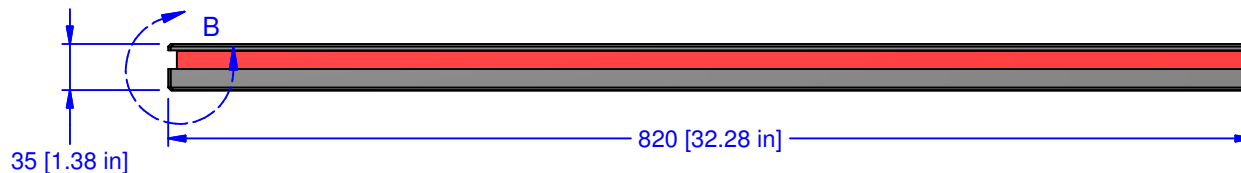

DETAIL B

SUBPLATE MAY BE TOE CLAMPED WITH CHICK **005-0254** TOE CLAMPS  
WHEN INSTALLING ON EITHER T-SLOTTED TABLES OR CHICK FOUNDATIONS

**CHICK** (800) 332-4425  
(724) 772-1644  
www.ChickWorkholding.com

PRODUCT INFORMATION PACKET (PIP)  
FOR WORKHOLDING PACKAGE  
**5RP-HAAS-00422**

5 OF 7	5RP-HAAS-00422	REV
2/12/2009	PIP	A

MOUNTING BOLTS AND T-NUTS REQUIRED FOR INSTALLATION TO A VMC TABLE ARE NOT INCLUDED WITH THE KIT.

WHEN ALIGNING THE SET-UP TO THE MACHINE AXES, BE SURE TO REFERENCE THE MULTI-LOK COLUMN (DO NOT REFERENCE UNMACHINED JAWS).

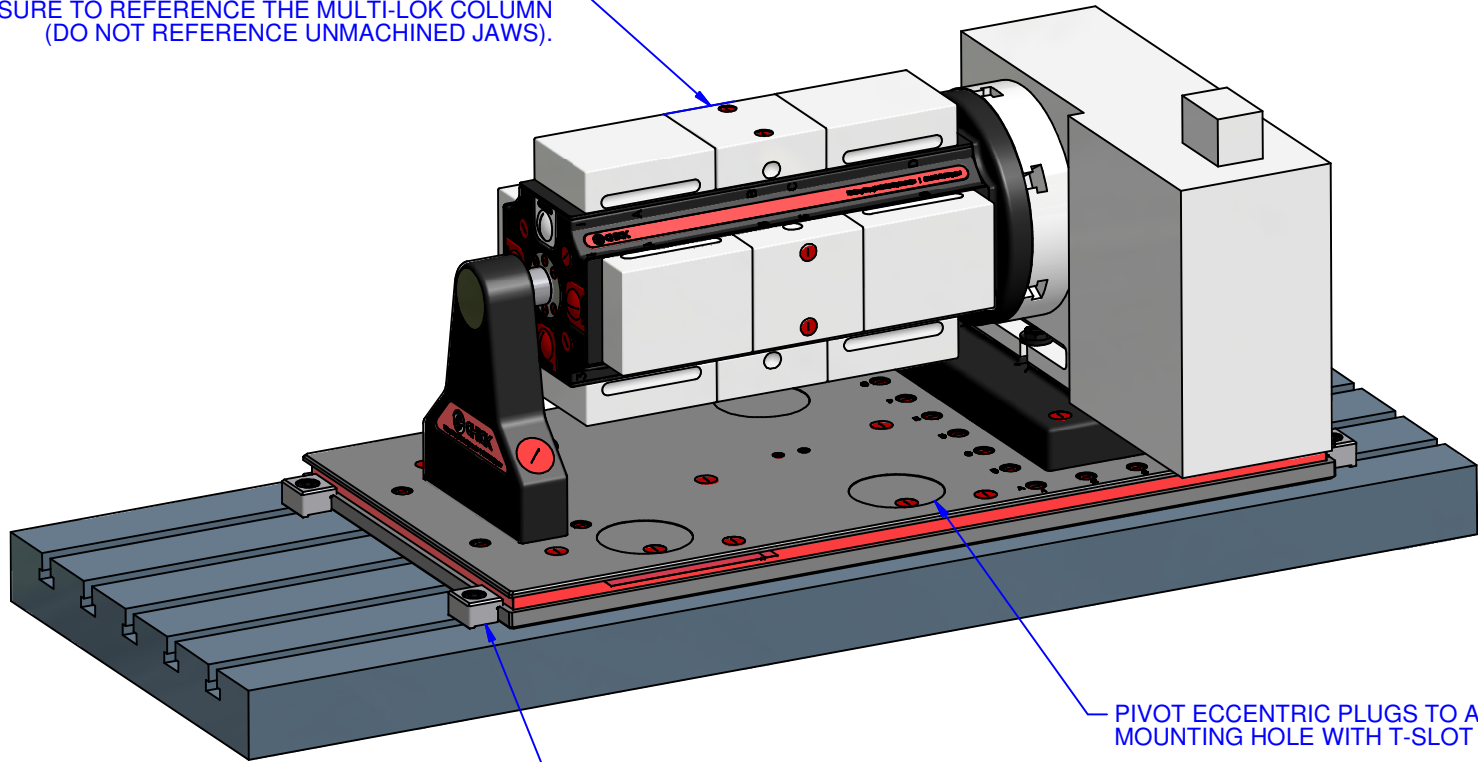

TOE CLAMP OUTSIDE EDGES

PIVOT ECCENTRIC PLUGS TO ALIGN MOUNTING HOLE WITH T-SLOT

THE SUBPLATE MAY BE MODIFIED WITH THE ADDITION OF A NEW MOUNTING HOLE PATTERN FOR UNIQUE INSTALLATION REQUIREMENTS

**CHICK** (800) 332-4425  
(724) 772-1644  
[www.ChickWorkholding.com](http://www.ChickWorkholding.com)

PRODUCT INFORMATION PACKET (PIP)  
FOR WORKHOLDING PACKAGE  
**5RP-HAAS-00422**

	6 OF 7	5RP-HAAS-00422	REV
2/12/2009		PIP	

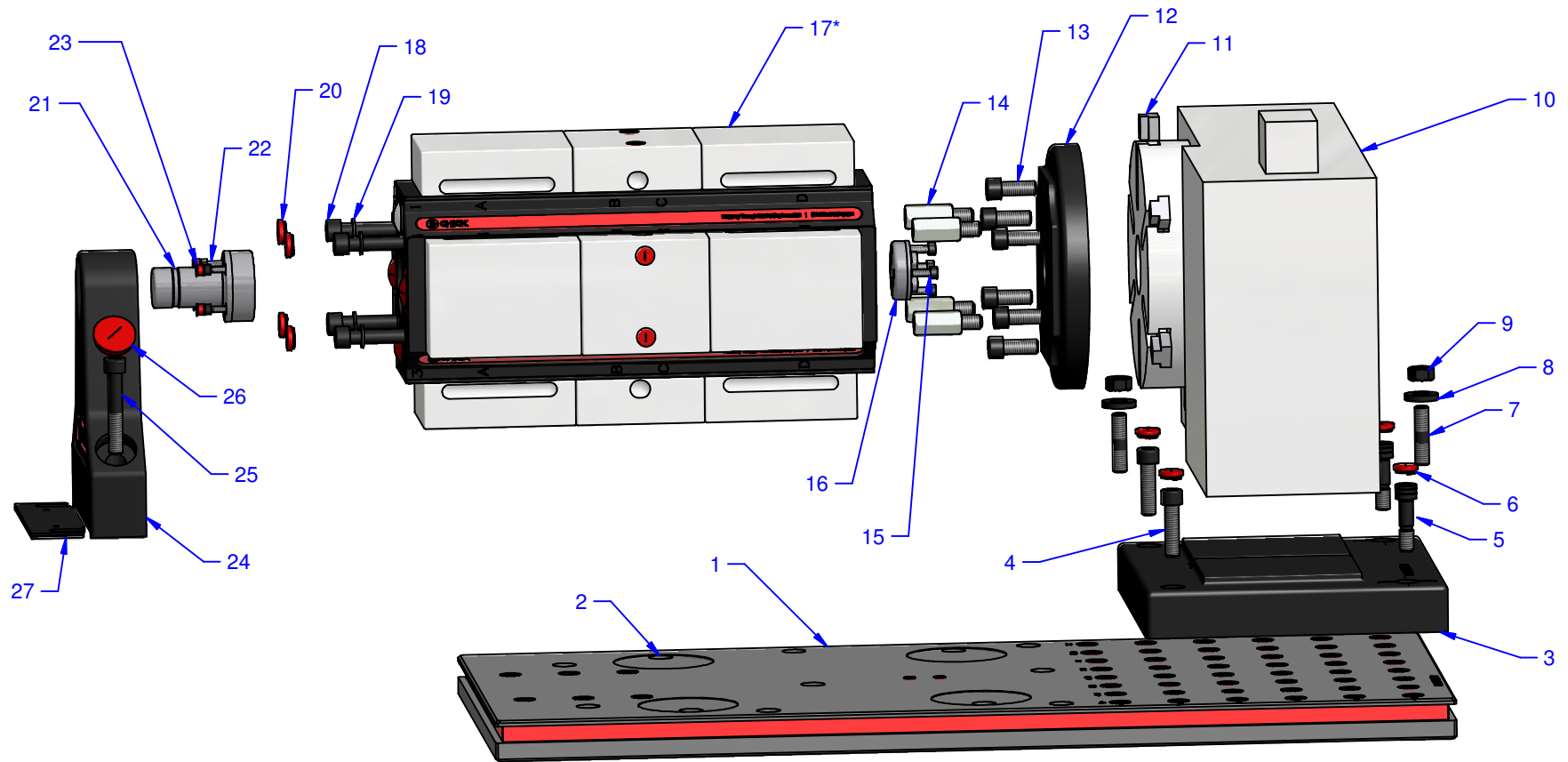

Parts ID			
Item	Part	Item	Part
1	Universal Subplate - 270-1200	15	SHCS - M6 X 16
2	Eccentric Mounting Plug	16	Column Pilot - 40mm
3	Riser Block - 270-0696	17	Multi-Lok - System 5 1040
4	SHCS - M12 X 45	18	SHCS - M12 X 200
5	Shoulder Bolt - M12 X 45	19	Washer - M12
6	Seal Plug - 18mm	20	Seal Plug - 18mm
7	Threaded Stud - M12 X 50	21	Stubshaft - 85mm Length
8	Washer - Hardened M12	22	SHCS - M5 X 35
9	Hex Nut - M12	23	Seal Plug - 9.5mm
10	Rotary Table - Haas HRT-210	24	Tailstock - 200mm Center Height
11	T-Nut - Modified M12	25	SHCS - M12 X 70
12	Adapter Plate - 060-0208-102	26	Seal Plug - 35mm
13	SHCS - M12 X 30	27	Shim Pack
14	Coupler Nut - M12		

\* For information on Multi-Lok, see 5ML1040-41 PIP

Order Numbers	
Parts	Item Number
1 - 2	<b>270-1200</b>
3 - 9	<b>270-0696</b>
11 - 13	<b>060-0208-102</b>
14, 18 - 19	<b>102-4035</b>
15 - 16	<b>MCP40</b>
17 - 20	<b>5ML1040-41</b>
21 - 23	<b>SBSFT</b>
24 - 27	<b>110-0080-200</b>

**CHICK** (800) 332-4425  
(724) 772-1644  
www.ChickWorkholding.com

PRODUCT INFORMATION PACKET (PIP)  
FOR WORKHOLDING PACKAGE  
**5RP-HAAS-00422**

7 OF 7	5RP-HAAS-00422	REV
2/12/2009	PIP	A

# ⑤ 5ML1040-41

SYSTEM 5

## 1040 Multi-Lok Product Information

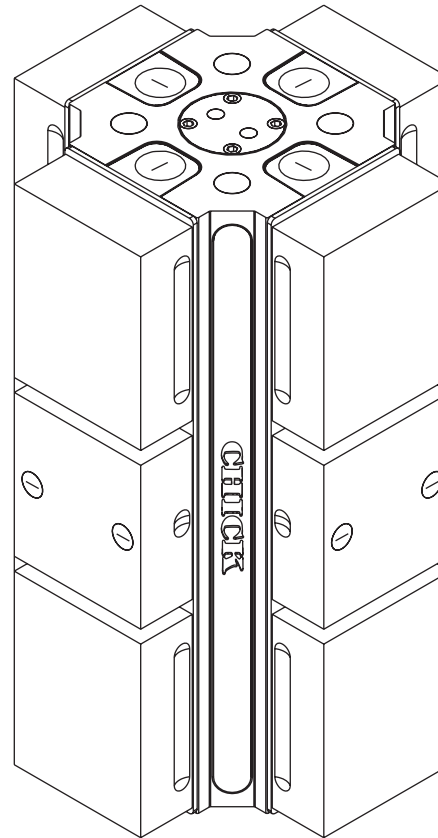

Notes

**CHICK WORKHOLDING SOLUTIONS, INC**  
500 Keystone Drive • Warrendale, PA 15086 USA  
Phone: (724) 772-1644 • Fax: (724) 772-1633  
Toll Free: (800) 33-CHICK • (800) 332-4425  
[www.ChickWorkholding.com](http://www.ChickWorkholding.com)



# 5 5ML1040-41

SYSTEM 5

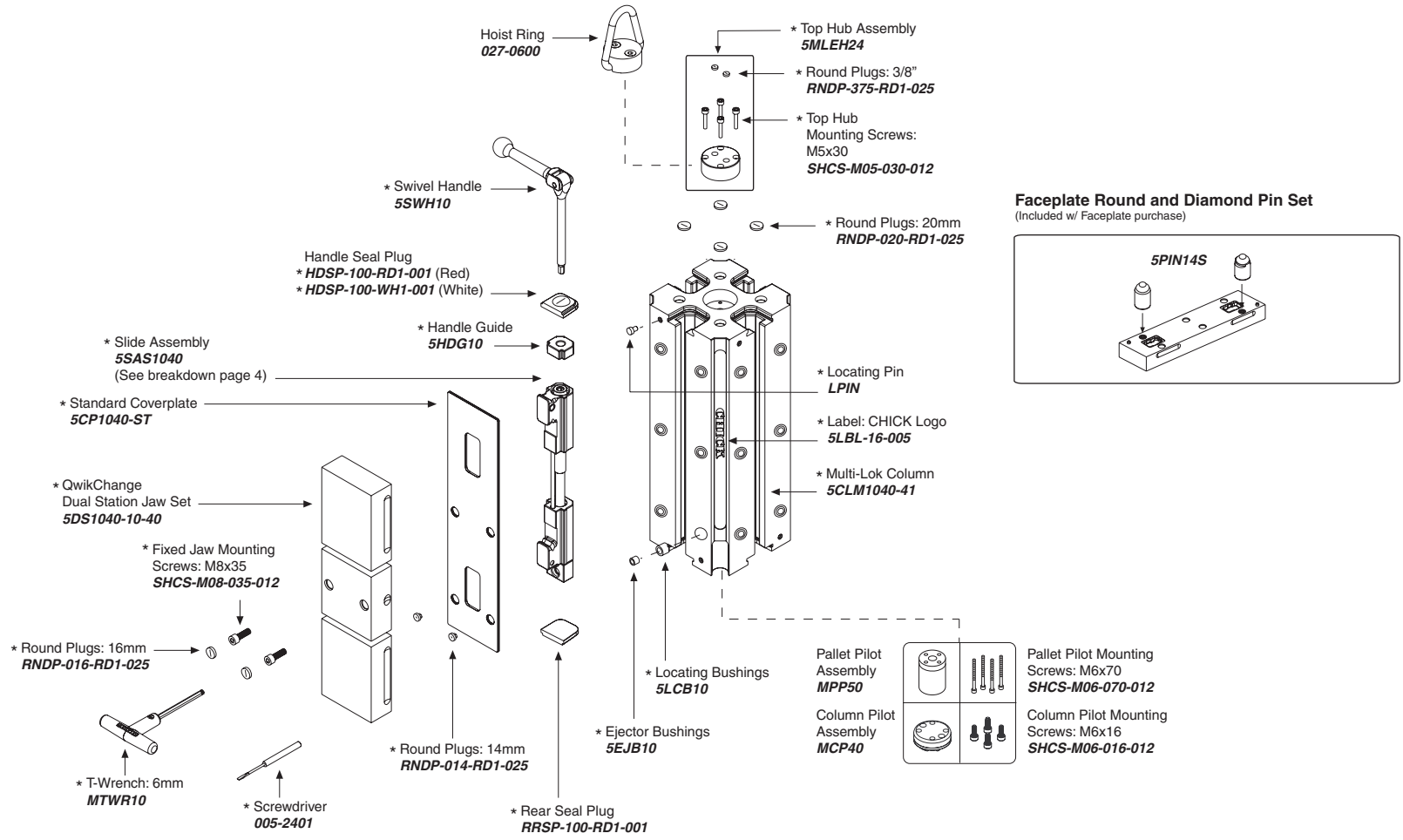

Notes

For QwikChange Jaw accessories, see pages 2-3

\* Included in a standard 1040 Multi-Lok

**CHICK WORKHOLDING SOLUTIONS, INC**  
 500 Keystone Drive • Warrendale, PA 15086 USA  
 Phone: (724) 772-1644 • Fax: (724) 772-1633  
 Toll Free: (800) 33-CHICK • (800) 332-4425  
[www.ChickWorkholding.com](http://www.ChickWorkholding.com)

# 5 5ML1040-41

SYSTEM 5

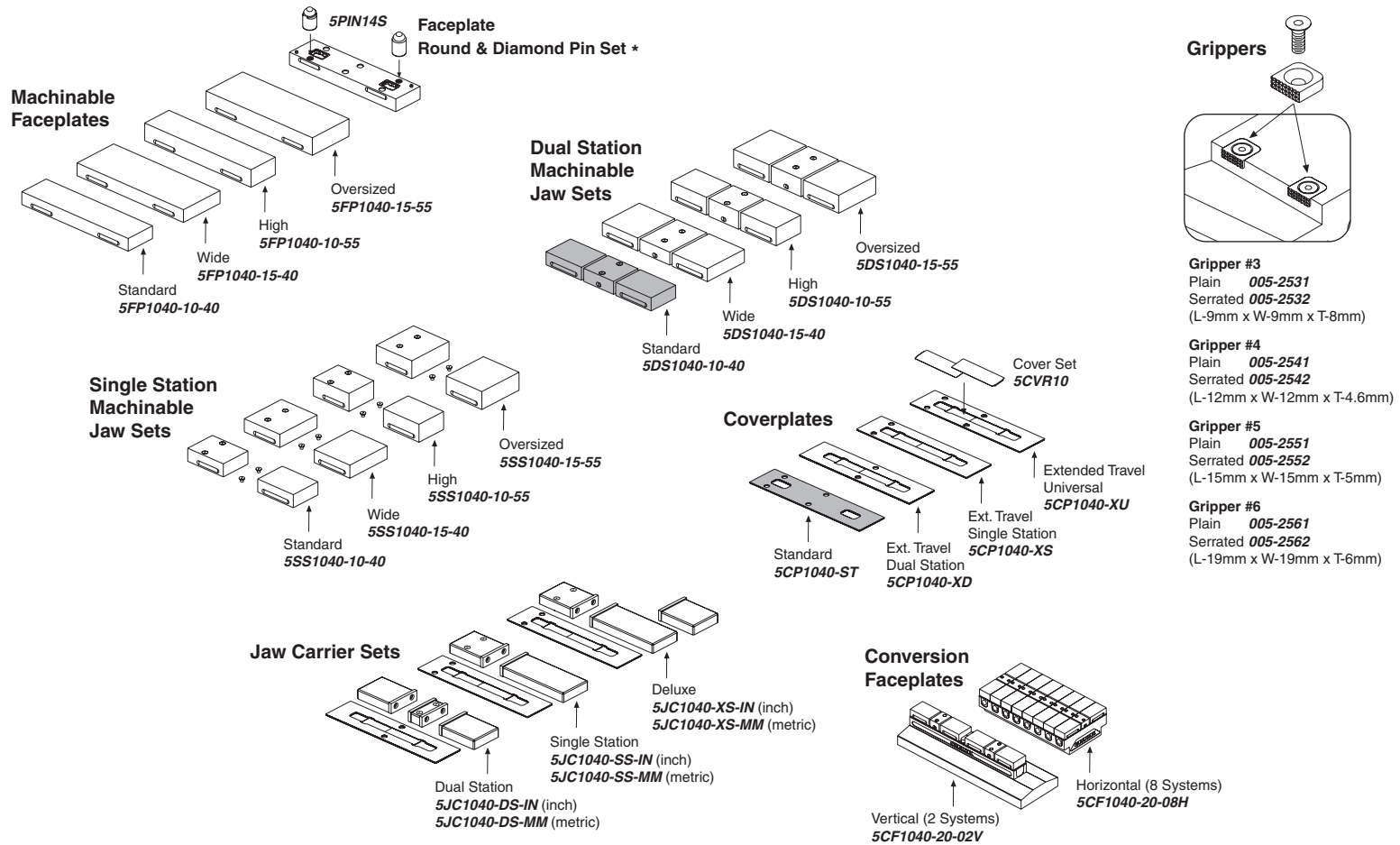

Notes

Grey item is included with a standard system

**CHICK WORKHOLDING SOLUTIONS, INC**  
500 Keystone Drive • Warrendale, PA 15086 USA  
Phone: (724) 772-1644 • Fax: (724) 772-1633  
Toll Free: (800) 33-CHICK • (800) 332-4425  
www.ChickWorkholding.com

# 5 5ML1040-41

## SYSTEM 5

### QwikChange Machinable Dual Station Jaws

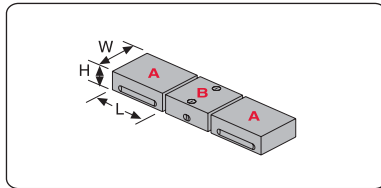

#### Individual Dual Station Jaws

- Standard  
**A** Moveable Jaw ..... **5MJ1040-10-40**  
 (W99mm, H40mm, L130mm)  
**B** Fixed Jaw ..... **5FJ1040-10-40**  
 (W99mm, H40mm, L110mm)
- Wide  
**A** Moveable Jaw ..... **5MJ1040-15-40**  
 (W148mm, H40mm, L130mm)  
**B** Fixed Jaw ..... **5FJ1040-15-40**  
 (W148mm, H40mm, L110mm)
- High  
**A** Moveable Jaw ..... **5MJ1040-10-55**  
 (W99mm, H55mm, L130mm)  
**B** Fixed Jaw ..... **5FJ1040-10-55**  
 (W99mm, H55mm, L110mm)
- Oversized  
**A** Moveable Jaw ..... **5MJ1040-15-55**  
 (W148mm, H55mm, L130mm)  
**B** Fixed Jaw ..... **5FJ1040-15-55**  
 (W148mm, H55mm, L110mm)

### QwikChange Machinable Single Station Jaws

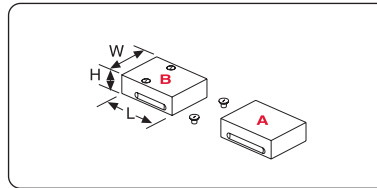

#### Individual Single Station Jaws

- Standard  
**A** Moveable Jaw ..... **5MJ1040-10-40**  
 (W99mm, H40mm, L130mm)  
**B** Fixed Jaw ..... **5SJ1040-10-40**  
 (W99mm, H40mm, L130mm)
- Wide  
**A** Moveable Jaw ..... **5MJ1040-15-40**  
 (W148mm, H40mm, L130mm)  
**B** Fixed Jaw ..... **5SJ1040-15-40**  
 (W148mm, H40mm, L130mm)
- High  
**A** Moveable Jaw ..... **5MJ1040-10-55**  
 (W99mm, H40mm, L130mm)  
**B** Fixed Jaw ..... **5SJ1040-10-55**  
 (W99mm, H40mm, L130mm)
- Oversized  
**A** Moveable Jaw ..... **5MJ1040-15-55**  
 (W148mm, H40mm, L130mm)  
**B** Fixed Jaw ..... **5SJ1040-15-55**  
 (W148mm, H40mm, L130mm)

### QwikChange Jaw Carriers

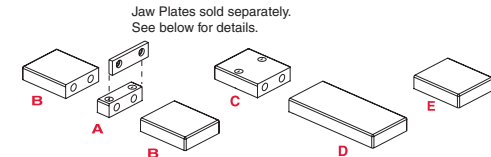

- | Jaw Carriers (Inch)    | Jaw Carriers (Metric)  |
|------------------------|------------------------|
| <b>A</b> 5JC1040-FC-IN | <b>A</b> 5JC1040-FC-MM |
| <b>B</b> 5JC1040-MC-IN | <b>B</b> 5JC1040-MC-MM |
| <b>C</b> 5JC1040-SC-IN | <b>C</b> 5JC1040-SC-MM |
| <b>D</b> 5JC1040-LM-IN | <b>D</b> 5JC1040-LM-MM |
| <b>E</b> 5JC1040-SM-IN | <b>E</b> 5JC1040-SM-MM |

- |                                |                                       |  |
|--------------------------------|---------------------------------------|--|
| <b>A</b> Dual Station Fixed    | <b>C</b> Single Station Fixed         | <b>E</b> Single Station Short Moveable |
| <b>B</b> Dual Station Moveable | <b>D</b> Single Station Long Moveable |  |

### Faceplate Round & Diamond Pin Set

(Included w/ Faceplate purchase)

Required for both Machinable and Conversion Faceplates.

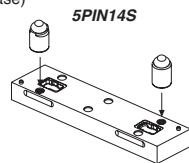

### Screws and Plugs

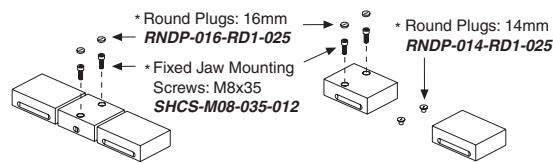

### Jaw Plates

#### HARD JAW PLATES

Standard (Set of 4)  
**JH4STD** (Inch)  
**MJH10** (Metric)

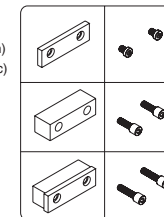

Standard Mounting Screws: 3/8-16x1/2"  
**LHCS-375-050-008** (Inch)  
**LHCS-M08-016-008** (Metric)

Thick (Set of 2)  
**JH4THK**

Thick Mounting Screws: 3/8-16x1"  
**SHCS-375-100-012**

Both Sizes  
**JH4STD** & **JH4THK**

Both Sizes Mounting Screws: 3/8-16x1.25"  
**SHCS-375-125-008**

#### SOFT JAW PLATES

Standard (Set of 4)  
**JS4AL**

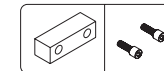

Soft Mounting Screws: 3/8-16x1"  
**SHCS-375-100-012**

### Notes

Grey item is included with a standard system

**CHICK WORKHOLDING SOLUTIONS, INC**  
 500 Keystone Drive • Warrendale, PA 15086 USA  
 Phone: (724) 772-1644 • Fax: (724) 772-1633  
 Toll Free: (800) 33-CHICK • (800) 332-4425  
 www.ChickWorkholding.com

# 5 5ML1040-41

SYSTEM 5

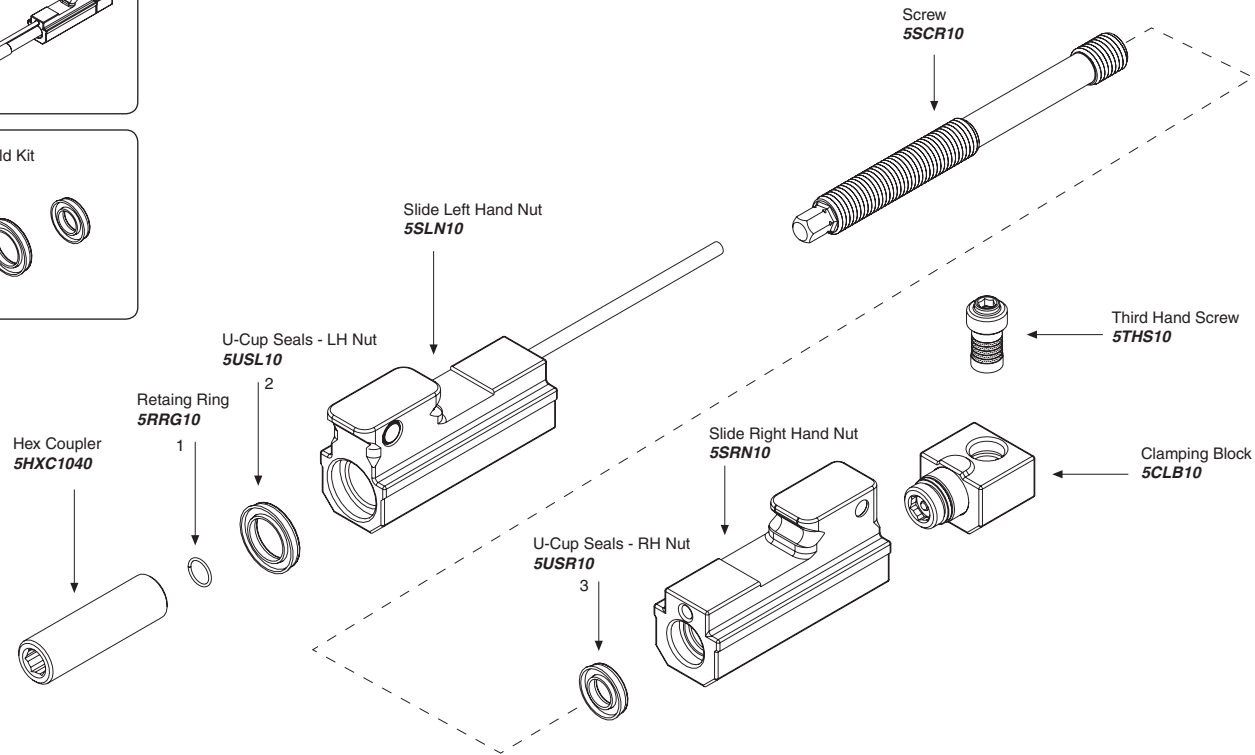
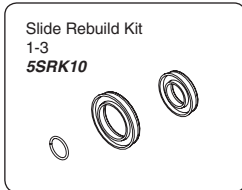
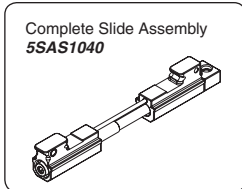

Notes

**CHICK WORKHOLDING SOLUTIONS, INC**  
 500 Keystone Drive • Warrendale, PA 15086 USA  
 Phone: (724) 772-1644 • Fax: (724) 772-1633  
 Toll Free: (800) 33-CHICK • (800) 332-4425  
[www.ChickWorkholding.com](http://www.ChickWorkholding.com)

**5** **5ML1040-41**  
SYSTEM 5

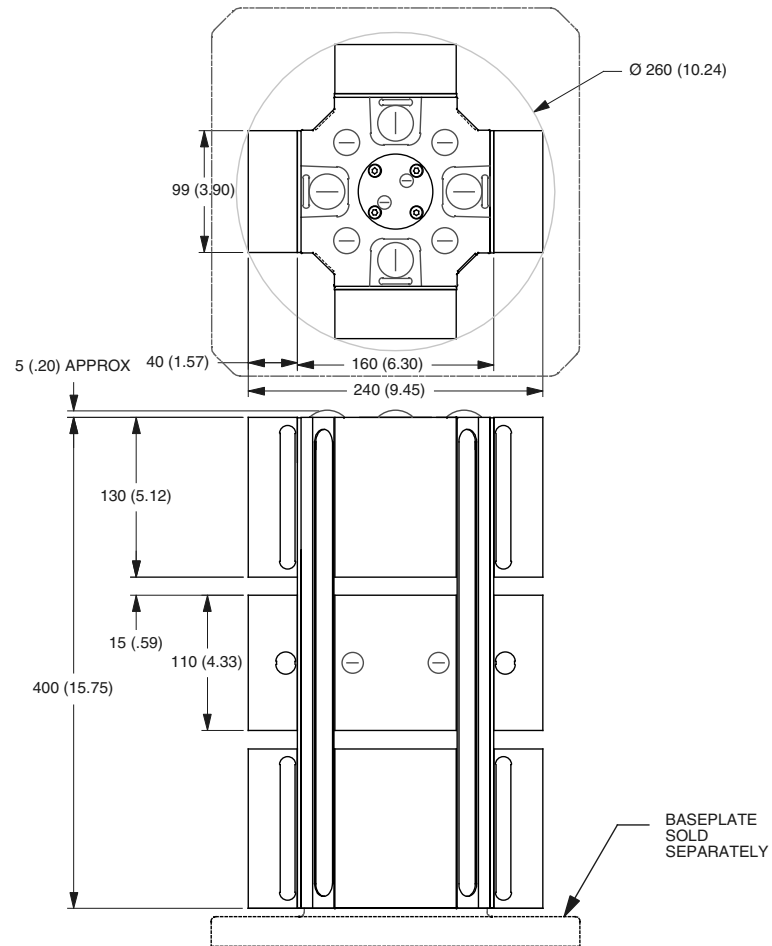

**Notes**

Dimensions are in mm (inches)  
 Dimensions include standard Dual Station Machinable Jaw Sets.  
 System weight: 47kg. (103lbs.)

**CHICK WORKHOLDING SOLUTIONS, INC**  
 500 Keystone Drive • Warrendale, PA 15086 USA  
 Phone: (724) 772-1644 • Fax: (724) 772-1633  
 Toll Free: (800) 33-CHICK • (800) 332-4425  
[www.ChickWorkholding.com](http://www.ChickWorkholding.com)

# 5 5ML1040-41

SYSTEM 5

## Dual Station

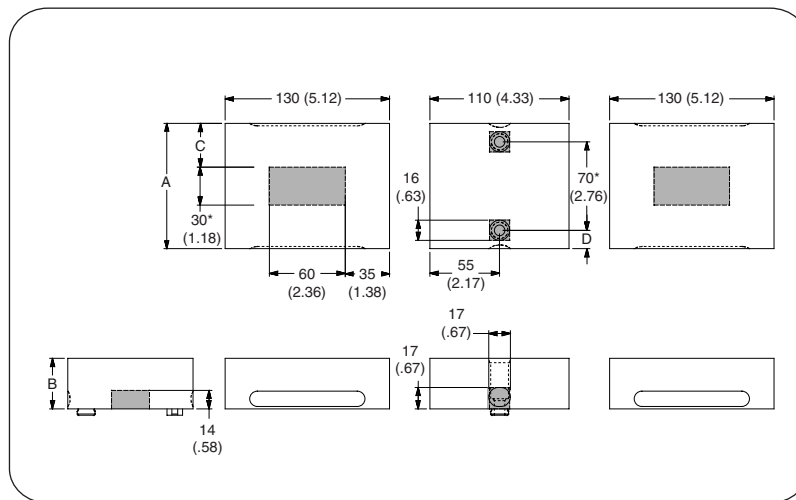

Item Number	Description	A	B	C	D
<b>5DS1040-10-40</b>	Standard	99 (3.90)	40 (1.57)	34.5 (1.36)	14.5 (.57)
<b>5DS1040-10-55</b>	High	99 (3.90)	55 (2.17)	34.5 (1.36)	14.5 (.57)
<b>5DS1040-15-40</b>	Wide	148 (5.83)	40 (1.57)	59 (2.32)	39 (1.54)
<b>5DS1040-15-55</b>	Oversized	148 (5.83)	55 (2.17)	59 (2.32)	39 (1.54)

## Single Station

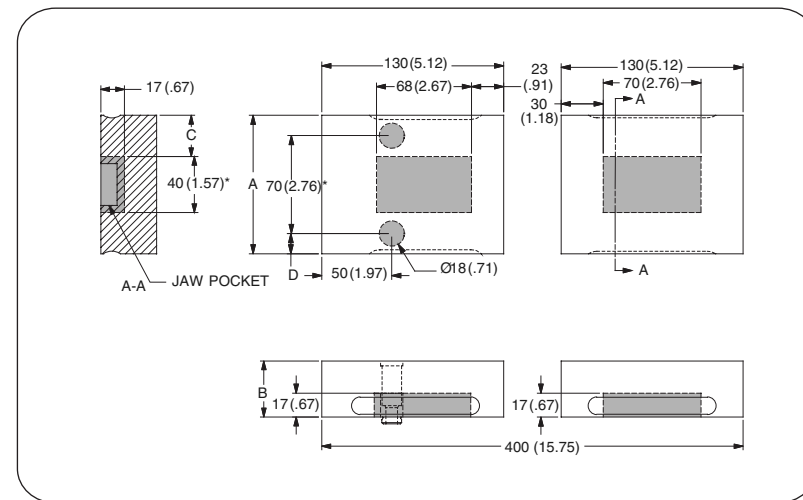

Item Number	Description	A	B	C	D
<b>5SS1040-10-40</b>	Standard	99 (3.90)	40 (1.57)	29.5 (1.16)	14.5 (.57)
<b>5SS1040-10-55</b>	High	99 (3.90)	55 (2.17)	29.5 (1.16)	14.5 (.57)
<b>5SS1040-15-40</b>	Wide	148 (5.83)	40 (1.57)	54 (2.13)	39 (1.54)
<b>5SS1040-15-55</b>	Oversized	148 (5.83)	55 (2.17)	54 (2.13)	39 (1.54)

### Notes

Grey area indicates no cut zone  
 All dimensions are MM [IN]  
 Dimensions centered on the "A" dimension.

**CHICK WORKHOLDING SOLUTIONS, INC**  
 500 Keystone Drive • Warrendale, PA 15086 USA  
 Phone: (724) 772-1644 • Fax: (724) 772-1633  
 Toll Free: (800) 33-CHICK • (800) 332-4425  
[www.ChickWorkholding.com](http://www.ChickWorkholding.com)

# 5 5ML1040-41 SYSTEM 5

## Dual Station

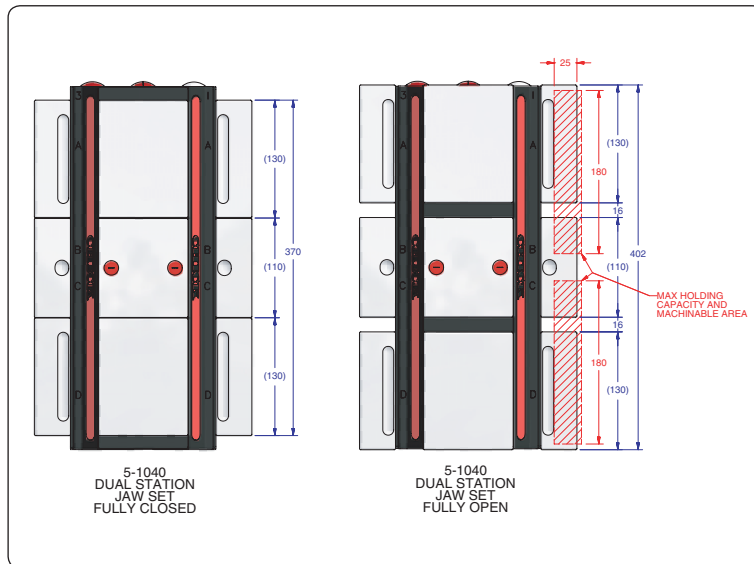

Item Number	Description	A	Jaw Width
5DS1040-10-40	Standard	26 (1.02)	99 (3.90)
5DS1040-10-55	High	41 (1.61)	99 (3.90)
5DS1040-15-40	Wide	26 (1.02)	148 (5.83)
5DS1040-15-55	Oversized	41 (1.61)	148 (5.83)

## Single Station

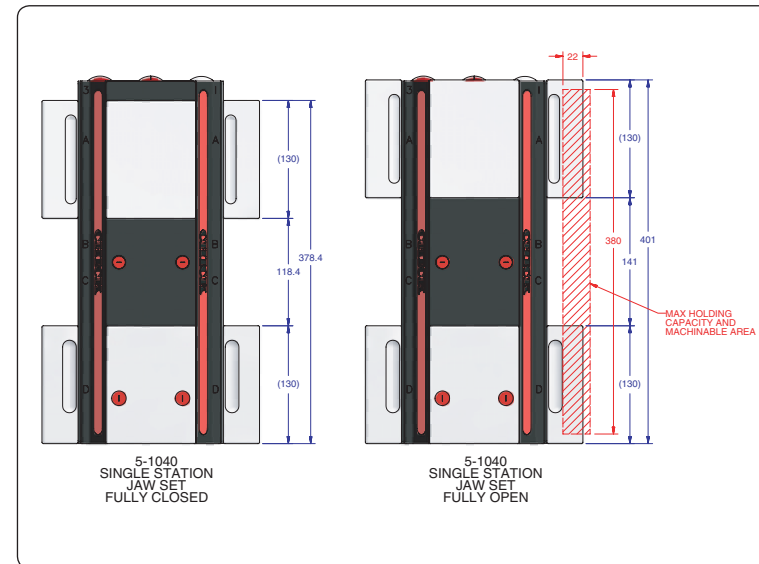

Item Number	Description	A	Jaw Width
5DS1040-10-40	Standard	26 (1.02)	99 (3.90)
5DS1040-10-55	High	41 (1.61)	99 (3.90)
5DS1040-15-40	Wide	26 (1.02)	148 (5.83)
5DS1040-15-55	Oversized	41 (1.61)	148 (5.83)

**Notes**

All dimensions are MM [IN]  
 \* Additional closure is available with an Extended Travel Coverplate.

**CHICK WORKHOLDING SOLUTIONS, INC**  
 500 Keystone Drive • Warrendale, PA 15086 USA  
 Phone: (724) 772-1644 • Fax: (724) 772-1633  
 Toll Free: (800) 33-CHICK • (800) 332-4425  
[www.ChickWorkholding.com](http://www.ChickWorkholding.com)

# 5 5ML1040-41

SYSTEM 5

**Pounds (lbs)**

Force	=	Torque	X	Slope
lbs	=	in-lb	x	8.0
lbs	=	ft-lbs	x	96

Torque (ft-lb)	Force (lbs)
0	0
10	962
20	1923
30	2885
40	3846
50	4808
52	5000

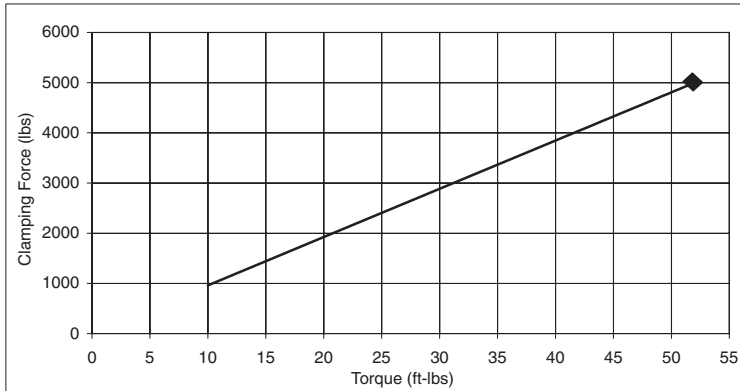

Note:  Maximum Recommended Torque. Actual results may vary.

**Kilo Newtons (kN)**

Force	=	Torque	X	Slope
N	=	N-m	x	315
kN	=	N-m	x	0.315

Torque (N-m)	Force (kN)
0	0.0
10	3.1
20	6.3
30	9.4
40	12.6
50	15.7
60	18.9
65	20.5
70	22.0

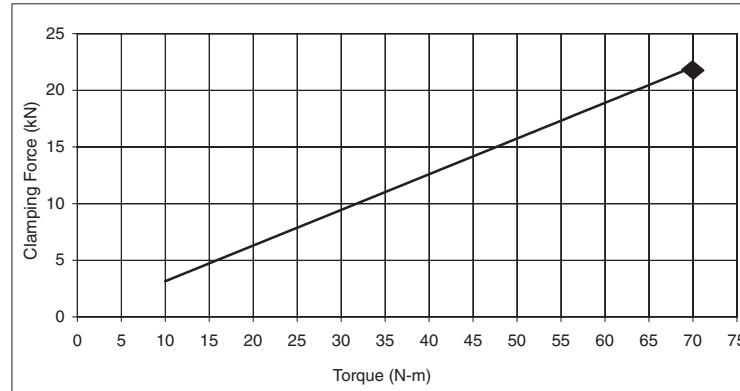

Note:  Maximum Recommended Torque. Actual results may vary.

Notes

**CHICK WORKHOLDING SOLUTIONS, INC**  
 500 Keystone Drive • Warrendale, PA 15086 USA  
 Phone: (724) 772-1644 • Fax: (724) 772-1633  
 Toll Free: (800) 33-CHICK • (800) 332-4425  
[www.ChickWorkholding.com](http://www.ChickWorkholding.com)