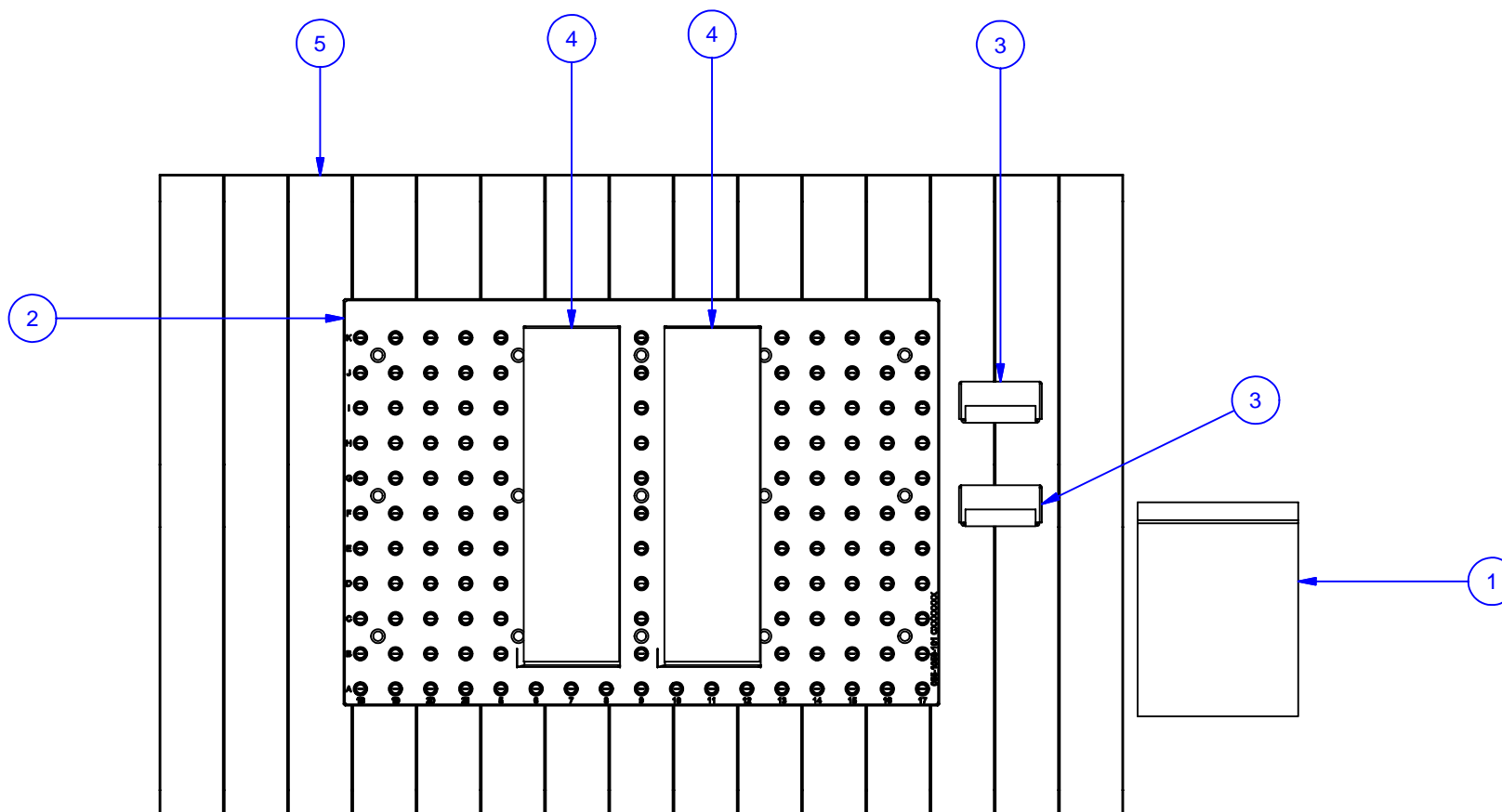

TABLE 1:

No	QTY	PN	ITEM	TYPE	FAM	STYLE	WEIGHT (g)
1	1	050-2-10025	KIT	FOUNDATION MOUNTING	14mm T-SLOT	(15) M12 X 35 SHCS	1635
2	1	055-1078-01	FOUNDATION ASSY	WP STANDARD	DECKEL MAHO DMC 635V	848 x 579	116300
3	2	058-9-10001	MPIN12S	ROUND & DIAMOND PIN SET	SYSTEM 5 & M SYSTEM	12mm DIA. x 19mm LONG	98
4	2	106-9-10003	5QL1040-AL	ALUMINUM QWIK-LOK	5-1040	SHIPPING GROUP	11340
5	1	990-50-002	PACKAGING	WOOD SHIPPING PALLET	36" X 54"	NA	24330



MATERIAL:	
HARDNESS:	NA
COATING:	NA
WEIGHT:	168000 g
COMMENTS:	UP TO (6) 5QL1040-AL's MAY BE USED

UNSPECIFIED TOLERANCES:

X ±0.2
X.X ±0.1
X.XX ±0.05
ANGLES ±0.5°

ALL DIMENSIONS ARE MILLIMETERS.

CHICK 500 Keystone Drive
Warrendale, PA USA
(800) 33-CHICK • (724) 772-1644
www.chick-workholding.com

UNSPECIFIED EDGES: BREAK 0.3 TO 0.8
UNSPECIFIED FILLETS: RADIUS 0.3 MAX

ITEM:	WORK PKG - VMC		
TYPE:	DECKEL MAHO DMC 635 V		
FAM:	5QL1040-AL (2)		
STYLE:	848 x 579 FOUNDATION		
BCE	1 OF 3	5VP-DECK-00002	REV A1
7/5/2006			

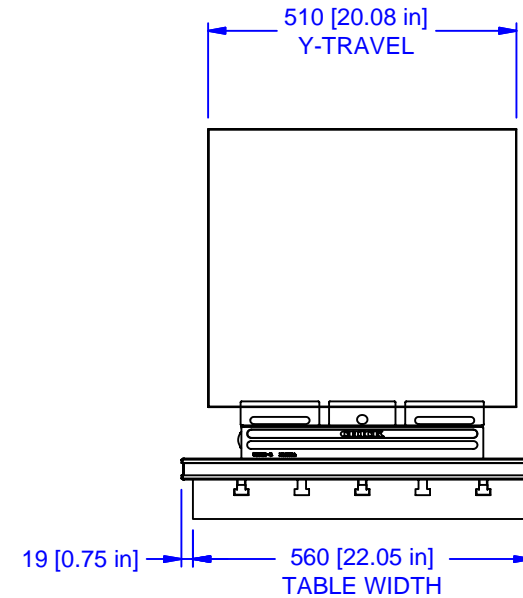
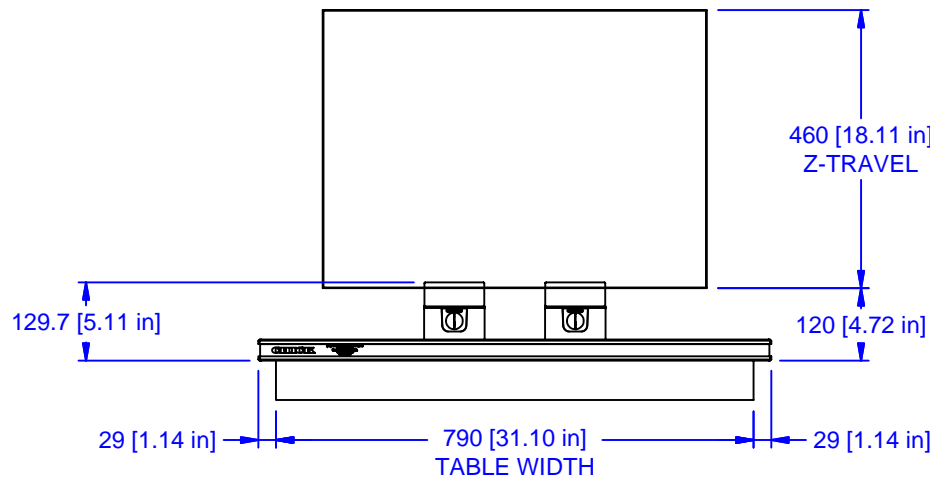
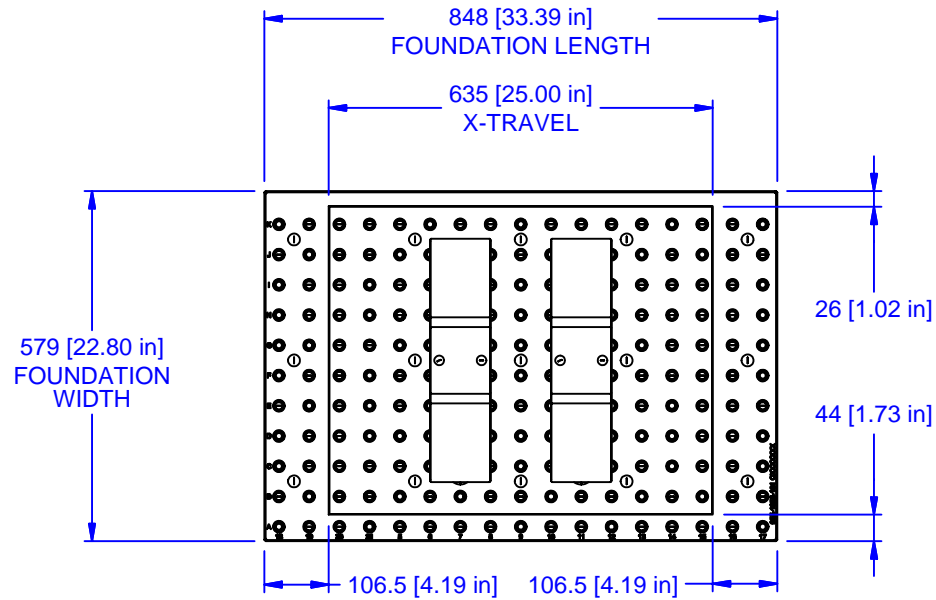

MATERIAL:	
HARDNESS:	NA
COATING:	NA
WEIGHT:	168000 g
COMMENTS:	UP TO (6) 5QL1040-AL's MAY BE USED

UNSPECIFIED TOLERANCES:

X	±0.2
X.X	±0.1
X.XX	±0.05
ANGLES	±0.5°

ALL DIMENSIONS ARE MILLIMETERS.

CHICK 500 Keystone Drive
Warrendale, PA USA
(800) 33-CHICK • (724) 772-1644
www.chick-workholding.com

UNSPECIFIED EDGES: BREAK 0.3 TO 0.8
UNSPECIFIED FILLETS: RADIUS 0.3 MAX

ITEM:	WORK PKG - VMC		
TYPE:	DECKEL MAHO DMC 635 V		
FAM:	5QL1040-AL (2)		
STYLE:	848 x 579 FOUNDATION		
BCE	2 OF 3	5VP-DECK-00002	REV A1
7/5/2006			

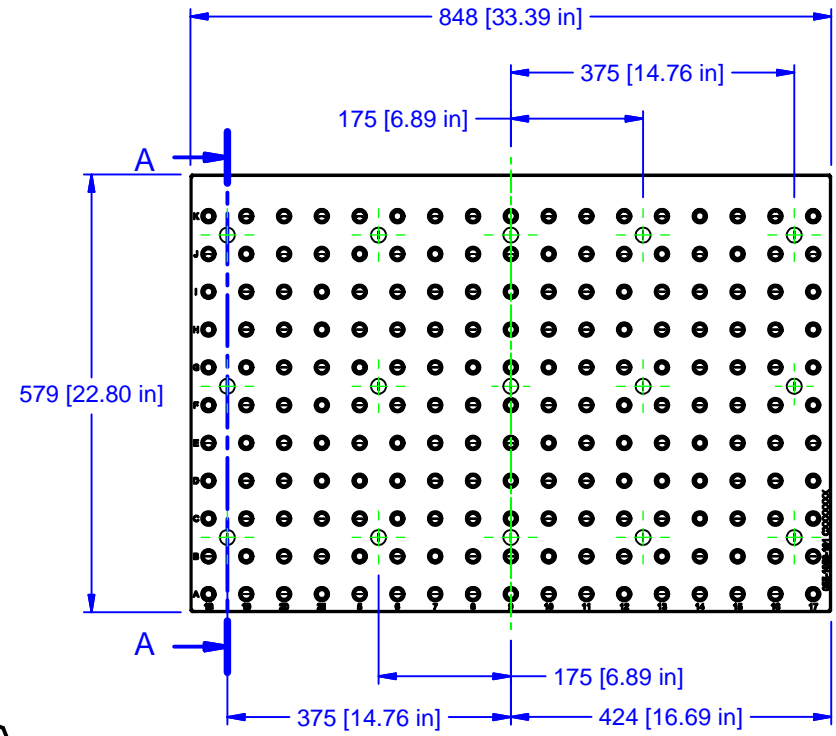
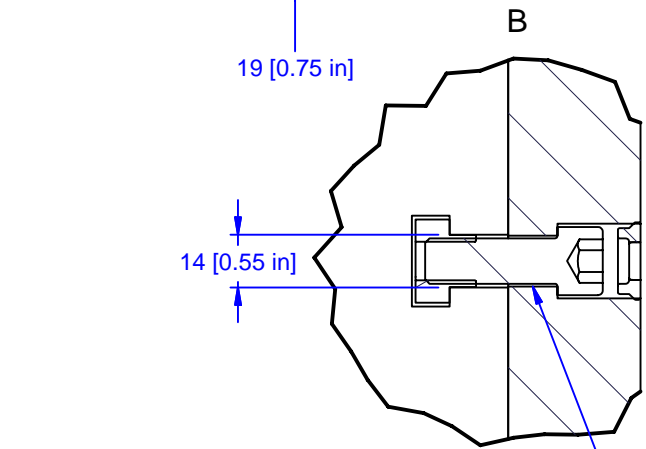
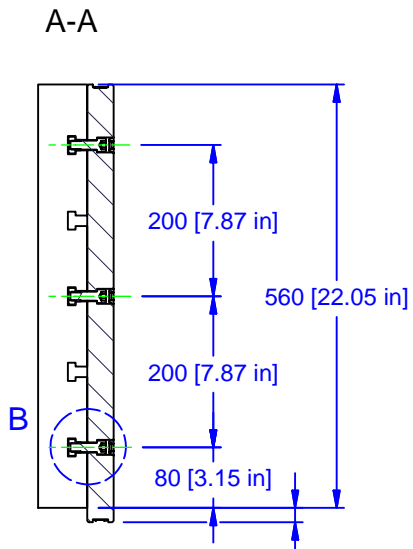

15x
M12 SHCS / 14mm T-SLOT

MATERIAL:	
HARDNESS: NA	
COATING: NA	
WEIGHT: 168000 g	
COMMENTS: UP TO (6) 5QL1040-AL's MAY BE USED	

UNSPECIFIED TOLERANCES:	
X	±0.2
X.X	±0.1
X.XX	±0.05
ANGLES	±0.5°
ALL DIMENSIONS ARE MILLIMETERS.	

CHICK 500 Keystone Drive
Warrendale, PA USA
(800) 33-CHICK • (724) 772-1644
www.chick-workholding.com

UNSPECIFIED EDGES: BREAK 0.3 TO 0.8
UNSPECIFIED FILLETS: RADIUS 0.3 MAX

ITEM: WORK PKG - VMC	REV
TYPE: DECKEL MAHO DMC 635 V	A1
FAM: 5QL1040-AL (2)	
STYLE: 848 x 579 FOUNDATION	
BCE	3 OF 3
7/5/2006	5VP-DECK-00002