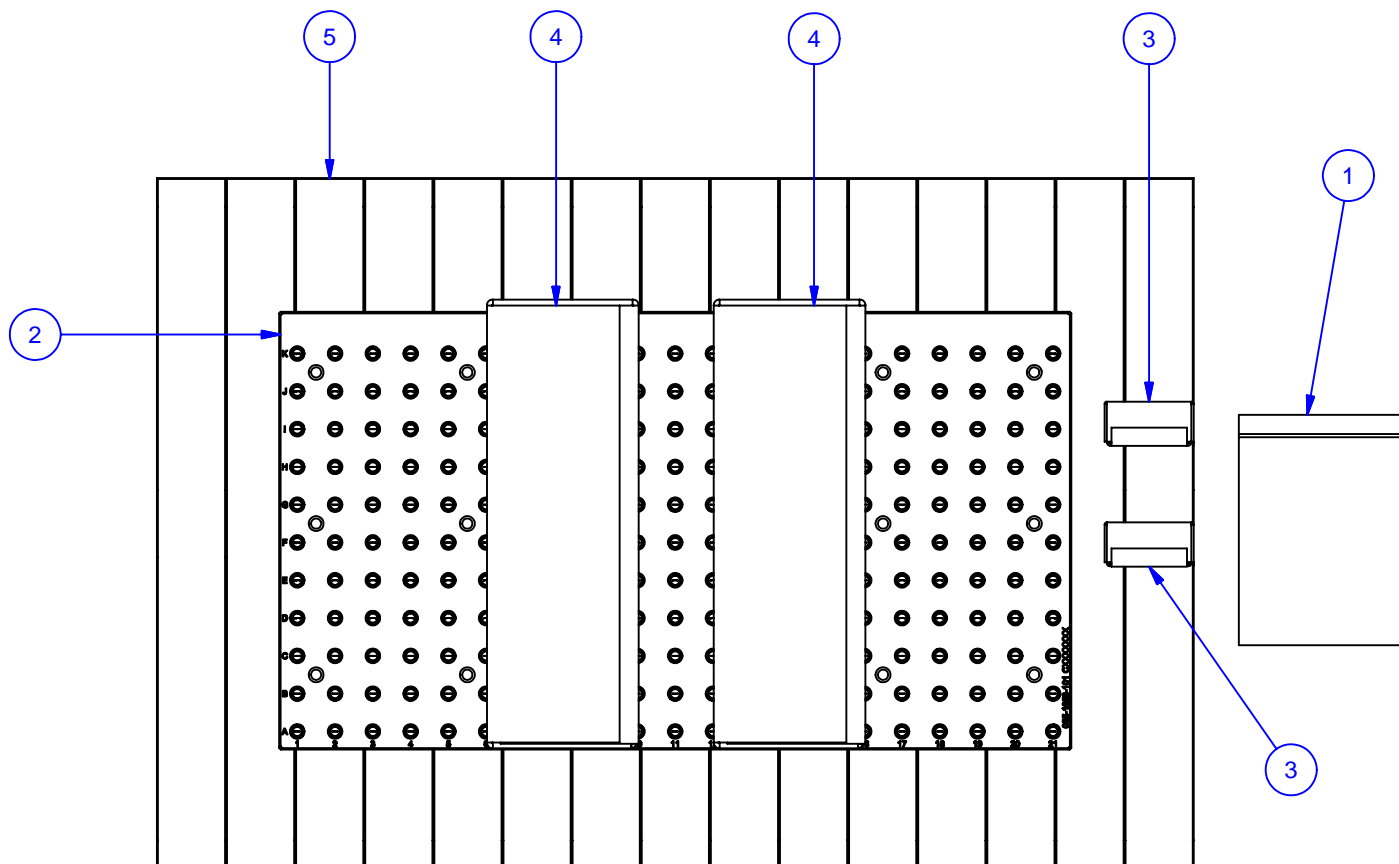

TABLE 1:

No	QTY	PN	ITEM	TYPE	FAM	STYLE	WEIGHT (g)
1	1	050-2-10068	KIT	FOUNDATION MOUNTING	14mm T-SLOT	(18) M12 X 35 SHCS	1975
2	1	055-1058-01	FOUNDATION ASSY	WP STANDARD	DECKEL MAHO DMC 835V	1048 X 579	143900
3	2	058-9-10001	MPIN12S	ROUND & DIAMOND PIN SET	SYSTEM 5 & M SYSTEM	12mm DIA. x 19mm LONG	98
4	2	156-9-10003	5QL1550-AL	ALUMINUM QWIK-LOK	5-1550	SHIPPING GROUP	29940
5	1	990-50-002	PACKAGING	WOOD SHIPPING PALLET	36" X 54"	NA	24330



MATERIAL:	
HARDNESS:	NA
COATING:	NA
WEIGHT:	230300 g
COMMENTS:	

UNSPECIFIED TOLERANCES:
 X ±0.2
 X.X ±0.1
 X.XX ±0.05
 ANGLES ±0.5°
 ALL DIMENSIONS ARE MILLIMETERS.

CHICK 500 Keystone Drive
 Warrendale, PA USA
 (800) 33-CHICK • (724) 772-1644
www.chick-workholding.com

UNSPECIFIED EDGES: BREAK 0.3 TO 0.8
 UNSPECIFIED FILLETS: RADIUS 0.3 MAX

ITEM:	WORK PKG - VMC		
TYPE:	DECKEL MAHO DMC 835 V		
FAM:	(2) 5QL1550-AL		
STYLE:	1048 X 579		
BCE	1 OF 3	5VP-DECK-00003	REV A1
7/5/2006			

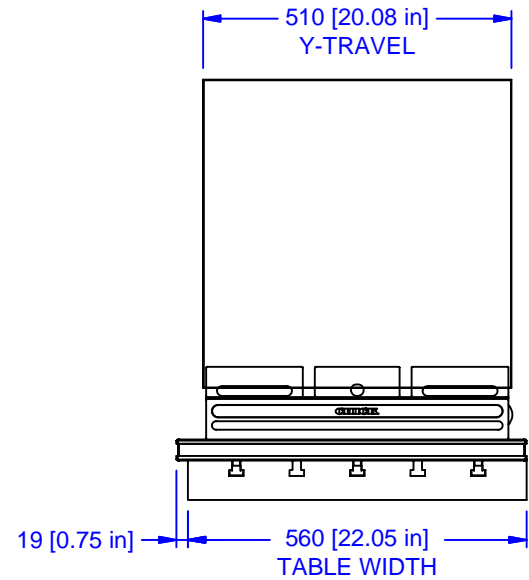
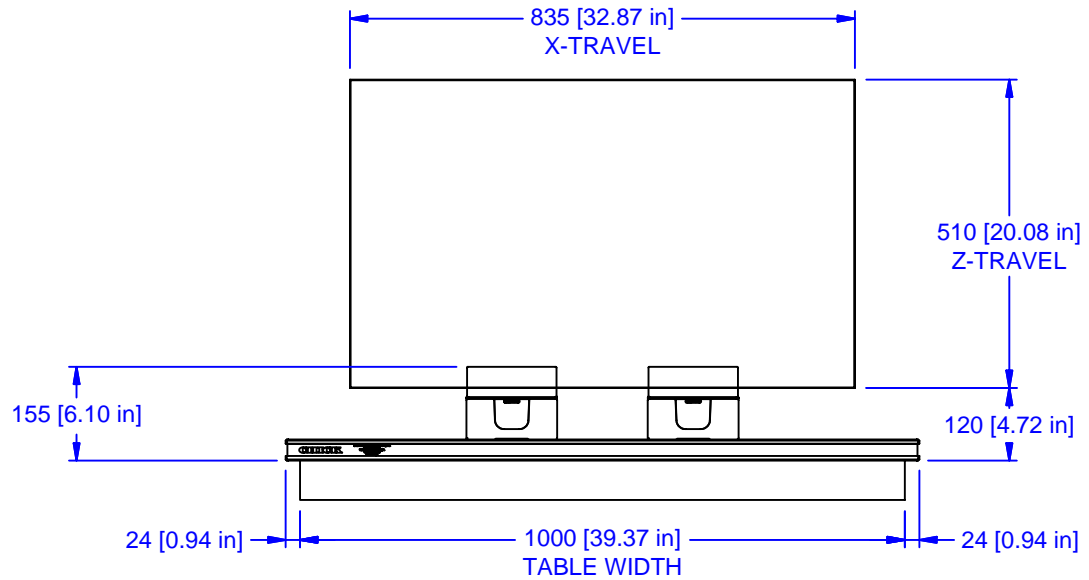
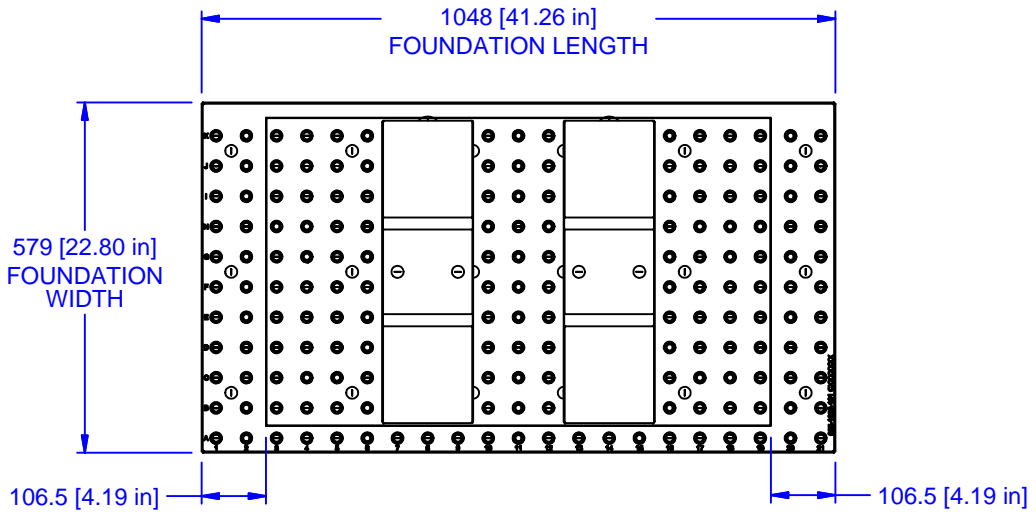

MATERIAL:	UNSPECIFIED TOLERANCES: X ±0.2 X.X ±0.1 X.XX ±0.05 ANGLES ±0.5° ALL DIMENSIONS ARE MILLIMETERS.	CHICK 500 Keystone Drive Warrendale, PA USA (800) 33-CHICK • (724) 772-1644 www.chick-workholding.com	ITEM: WORK PKG - VMC	2 OF 3 7/5/2006	REV A1
HARDNESS: NA			TYPE: DECKEL MAHO DMC 835 V		
COATING: NA			FAM: (2) 5QL1550-AL		
WEIGHT: 230300 g			STYLE: 1048 X 579		
COMMENTS:			UNSPECIFIED EDGES: BREAK 0.3 TO 0.8 UNSPECIFIED FILLETS: RADIUS 0.3 MAX		

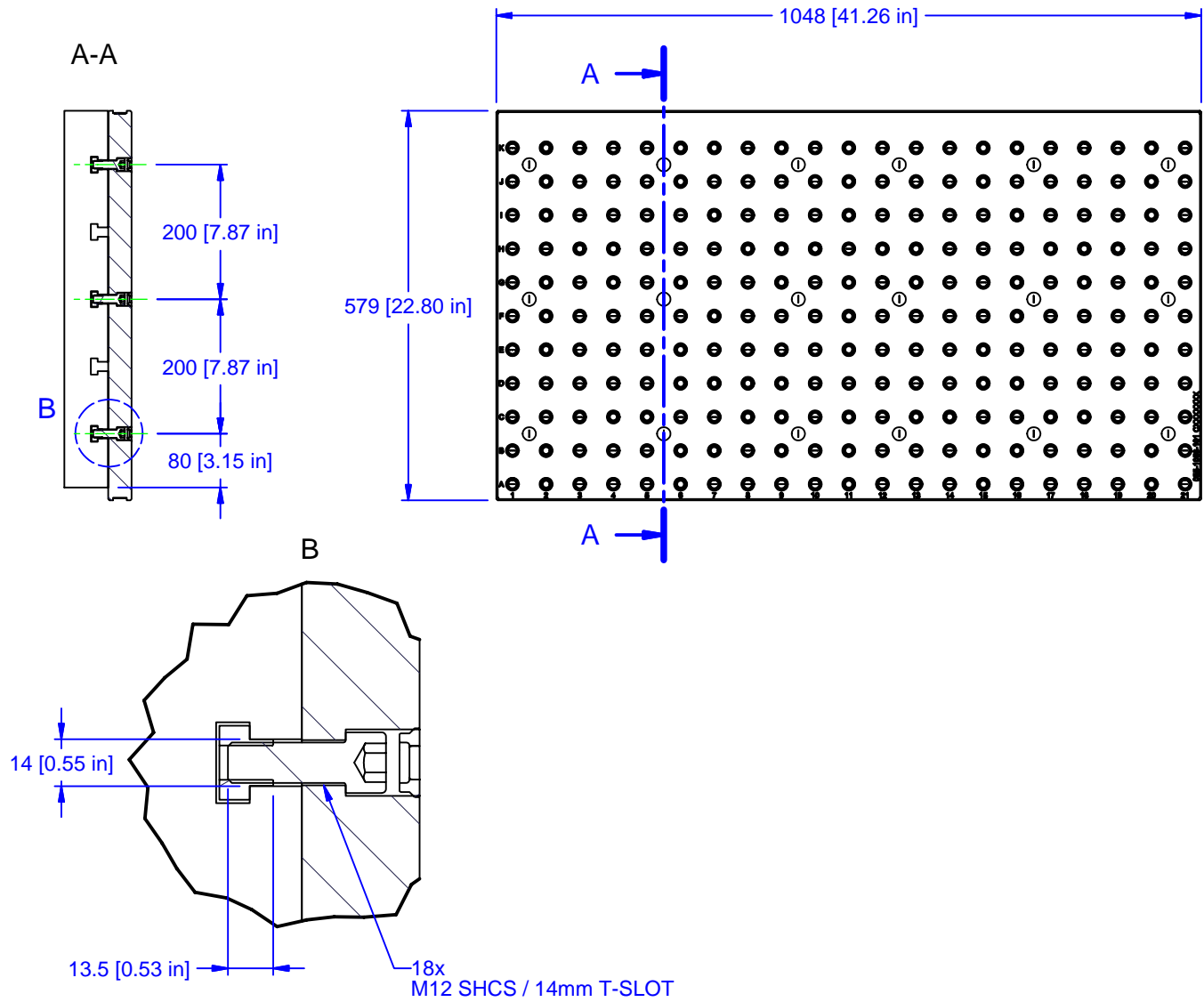

MATERIAL:	UNSPECIFIED TOLERANCES:	CHICK 500 Keystone Drive Warrendale, PA USA (800) 33-CHICK • (724) 772-1644 www.chick-workholding.com	ITEM: WORK PKG - VMC		REV
HARDNESS: NA	X ±0.2		TYPE: DECKEL MAHO DMC 835 V		
COATING: NA	X.X ±0.1	UNSPECIFIED EDGES: BREAK 0.3 TO 0.8 UNSPECIFIED FILLETS: RADIUS 0.3 MAX	FAM: (2) 5QL1550-AL		5VP-DECK-00003
WEIGHT: 230300 g	X.XX ±0.05		STYLE: 1048 X 579		
COMMENTS:	ANGLES ±0.5°	BCE 3 OF 3		7/5/2006	A1
ALL DIMENSIONS ARE MILLIMETERS.					