

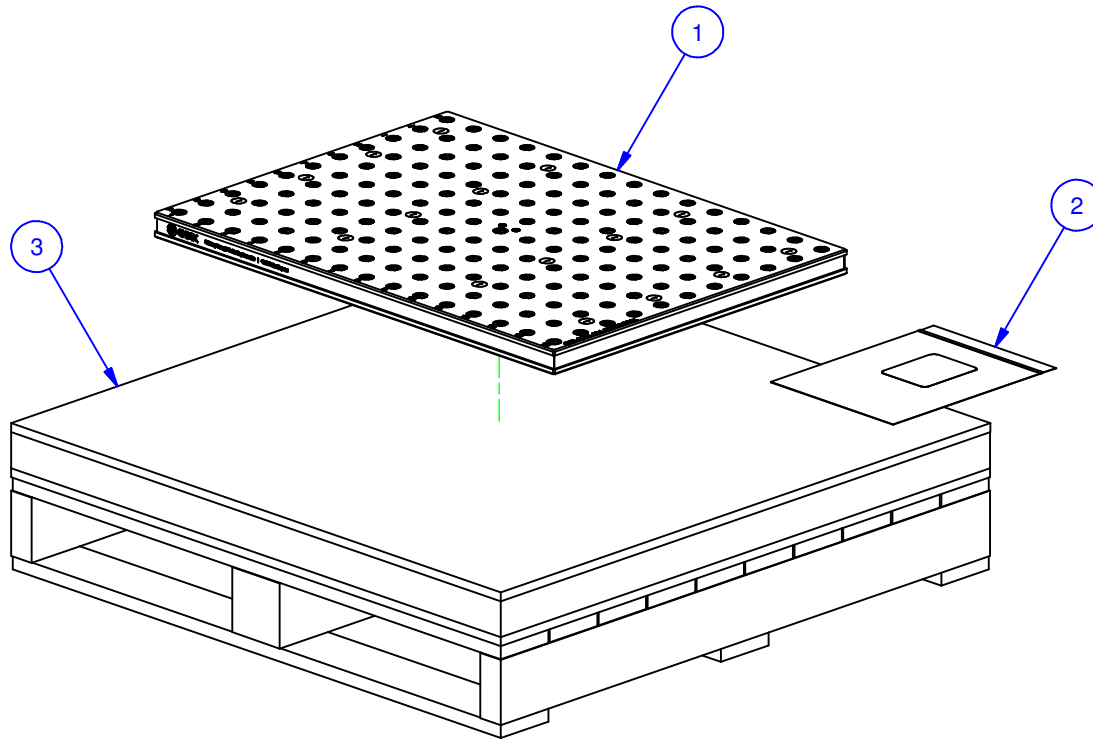



PARTS LIST						
No	QTY	PN	ITEM	TYPE	FAM	STYLE
1	1	055-1581-01	FOUNDATION ASSEMBLY	DECKEL MAHO DMU 50 (FIXED)	STANDARD GRID	748 X 549
2	1	050-2-10098	KIT	FOUNDATION MOUNTING	14mm T-SLOT	(16) M12 X 35 SHCS / 14mm T-NUT
3	1	990-50-021	PACKAGING	SHIPPING CRATE	FOUNDATIONS	36" X 36"



MATERIAL: <a href="#">NA</a>	UNSPECIFIED TOLERANCES: X ±0.2 X.X ±0.1 X.XX ±0.05 ANGLES ±0.5° ALL DIMENSIONS ARE MILLIMETERS.	 (800) 332-4425 (724) 772-1644 <a href="http://www.ChickWorkholding.com">www.ChickWorkholding.com</a>	ITEM: <a href="#">WORK PKG - VMC</a>	TDD   1 OF 3   REV 12/20/2011   5VP-DECK-00089   A
HARDNESS: <a href="#">NA</a>			TYPE: <a href="#">DECKEL MAHO DMU 50 (FIXED)</a>	
COATING: <a href="#">NA</a>			FAM: <a href="#">FOUNDATION ONLY</a>	
WEIGHT: <a href="#">128486 g</a>			STYLE: <a href="#">748 X 549</a>	
COMMENTS:		UNSPECIFIED EDGES: BREAK 0.3 TO 0.8 UNSPECIFIED FILLETS: RADIUS 0.3 MAX		

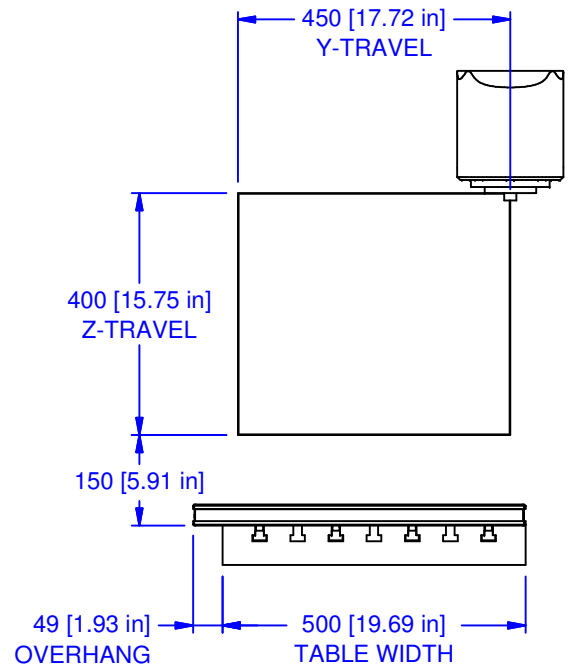
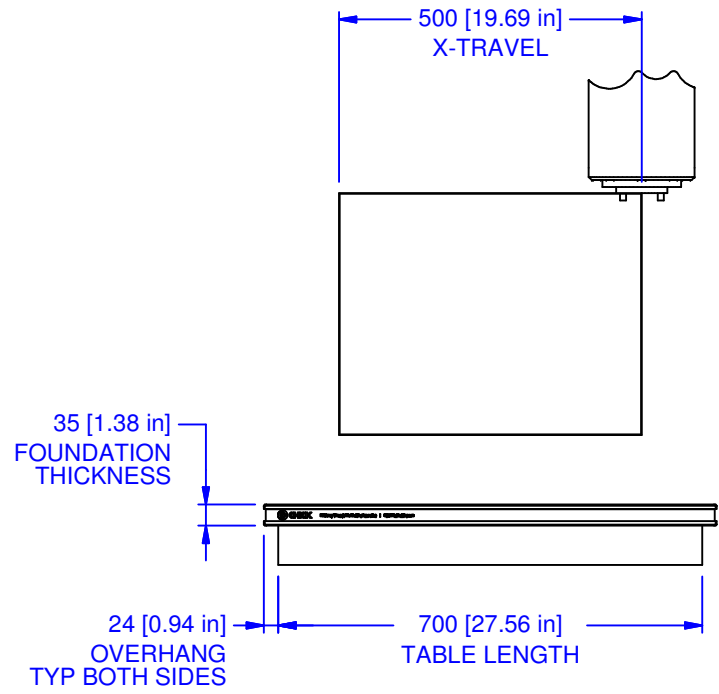
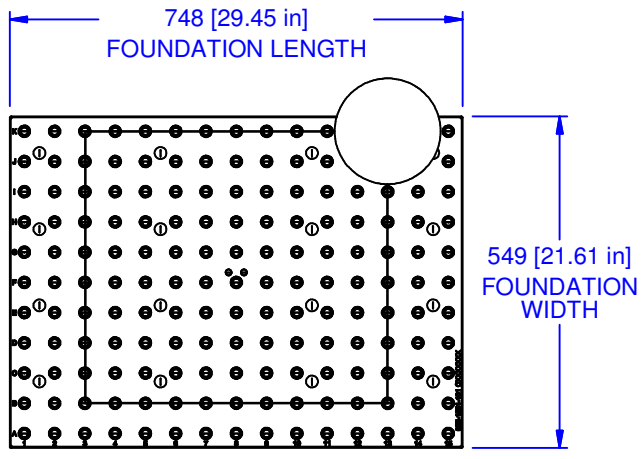

MATERIAL: <b>NA</b>	UNSPECIFIED TOLERANCES: X ±0.2 X.X ±0.1 X.XX ±0.05 ANGLES ±0.5° ALL DIMENSIONS ARE MILLIMETERS.	 (800) 332-4425 (724) 772-1644 <a href="http://www.ChickWorkholding.com">www.ChickWorkholding.com</a>	ITEM: <b>WORK PKG - VMC</b>		TDD 2 OF 3 12/20/2011	REV <b>A</b>
HARDNESS: <b>NA</b>			TYPE: <b>DECKEL MAHO DMU 50 (FIXED)</b>			
COATING: <b>NA</b>			FAM: <b>FOUNDATION ONLY</b>			
WEIGHT: <b>128486 g</b>			STYLE: <b>748 X 549</b>			
COMMENTS:	UNSPECIFIED EDGES: BREAK 0.3 TO 0.8 UNSPECIFIED FILLETS: RADIUS 0.3 MAX		<b>SVP-DECK-00089</b>			

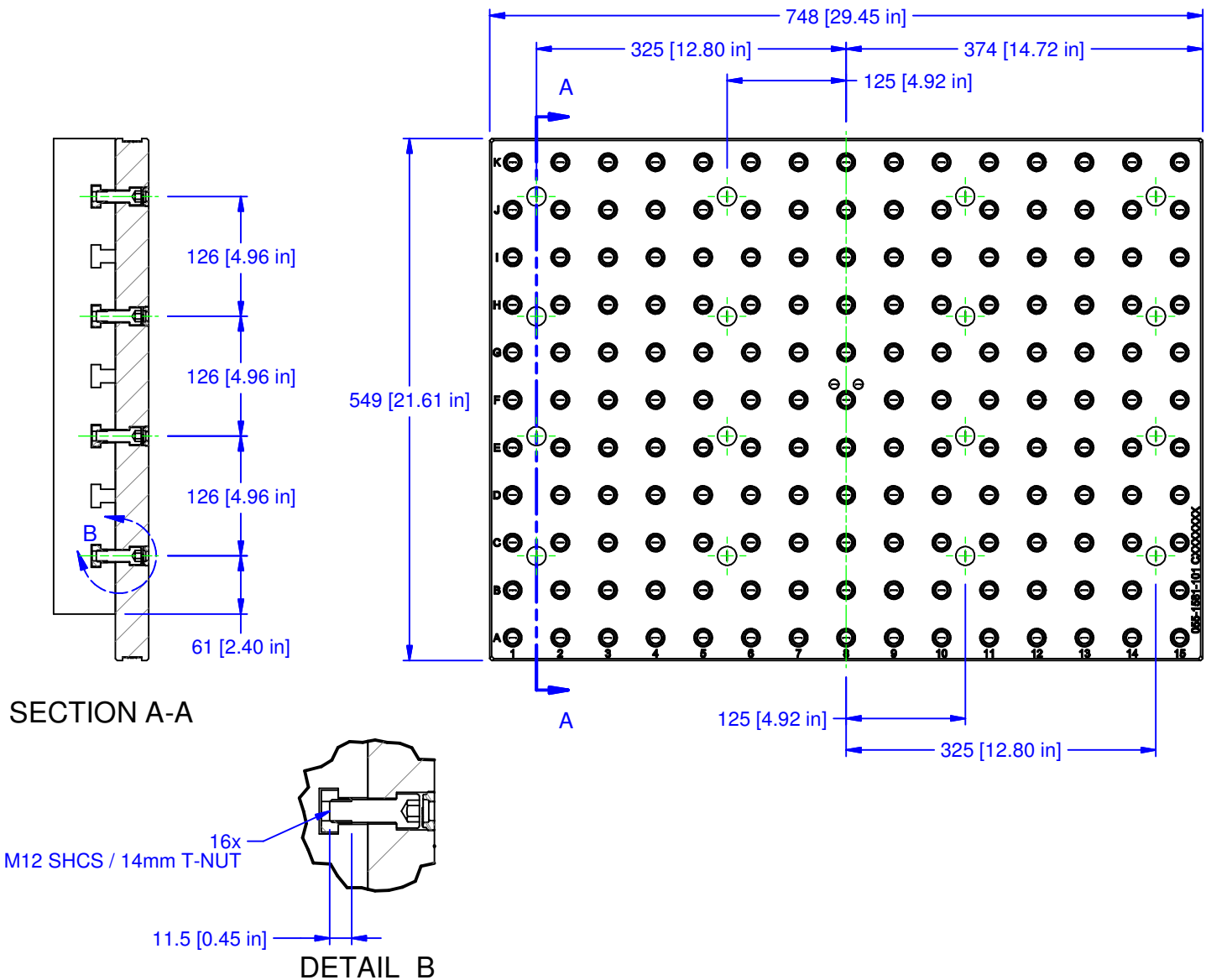

MATERIAL:	NA
HARDNESS:	NA
COATING:	NA
WEIGHT:	128486 g
COMMENTS:	

UNSPECIFIED TOLERANCES:  
 X ±0.2  
 X.X ±0.1  
 X.XX ±0.05  
 ANGLES ±0.5°  
 ALL DIMENSIONS ARE MILLIMETERS.

**CHICK** (800) 332-4425  
 (724) 772-1644  
 www.ChickWorkholding.com

UNSPECIFIED EDGES: BREAK 0.3 TO 0.8  
 UNSPECIFIED FILLETS: RADIUS 0.3 MAX

ITEM: WORK PKG - VMC		REV A
TYPE: DECKEL MAHO DMU 50 (FIXED)		
FAM: FOUNDATION ONLY		5VP-DECK-00089
STYLE: 748 X 549		
TDD	3 OF 3	
12/20/2011		