

## 5VP-HAAS-00104

This workholding package is designed for your HAAS VF-5 machining center.

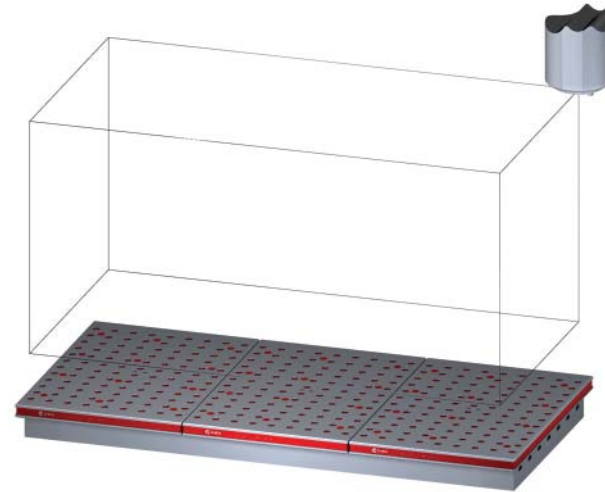

Workholding package



Workholding package  
in machine envelope

Notes

**CHICK WORKHOLDING SOLUTIONS, INC.**  
500 Keystone Drive • Warrendale, PA 15086 USA  
Phone: (724) 772-1644 • Fax: (724) 772-1633  
[www.ChickWorkholding.com](http://www.ChickWorkholding.com)

# 5VP-HAAS-00104

This workholding package is designed for your HAAS VF-5 machining center.

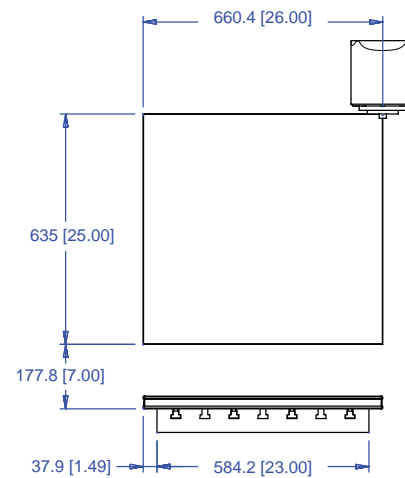
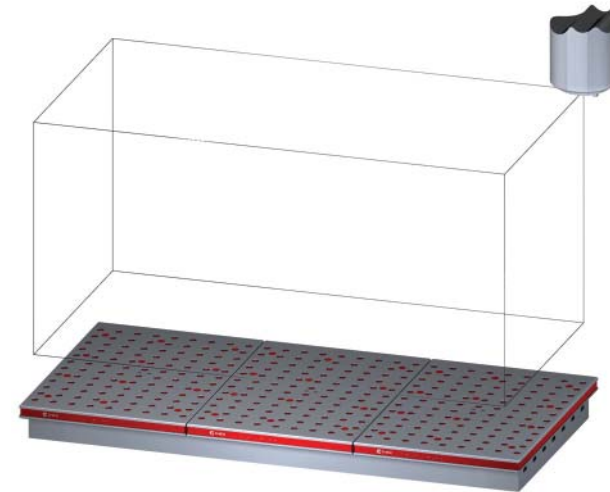
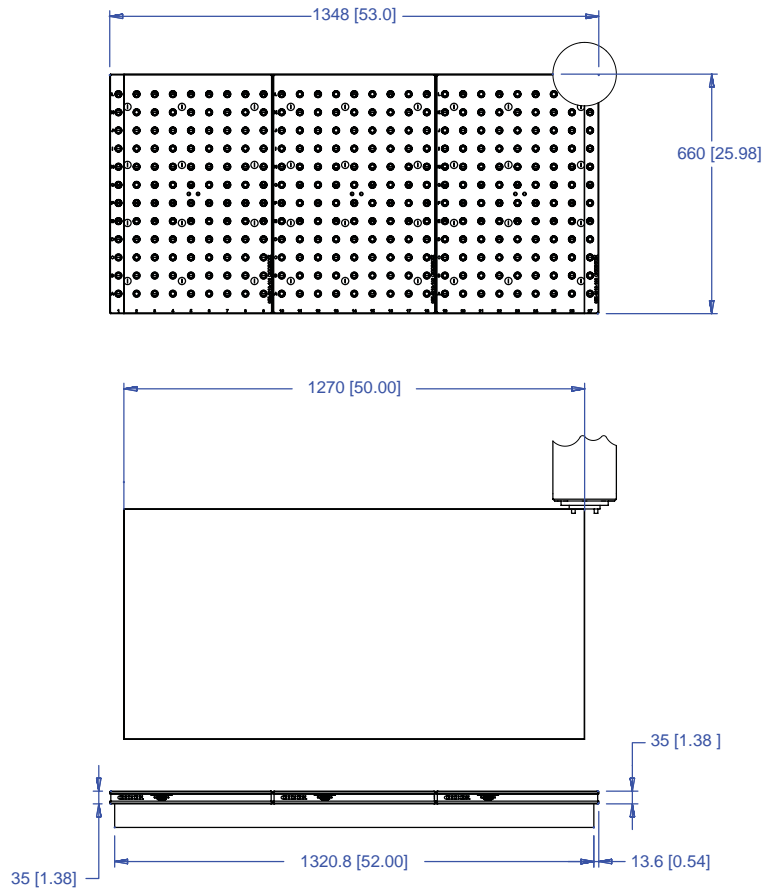

**Notes**

Machine travel may be limited by mechanical interference and/or machine safety zones. Please consult your machine's operating instructions for more information.

All dimensions are MM [IN]

**CHICK WORKHOLDING SOLUTIONS, INC.**  
 500 Keystone Drive • Warrendale, PA 15086 USA  
 Phone: (724) 772-1644 • Fax: (724) 772-1633  
[www.ChickWorkholding.com](http://www.ChickWorkholding.com)

# 5VP-HAAS-00104

This workholding package is designed for your HAAS VF-5 machining center.

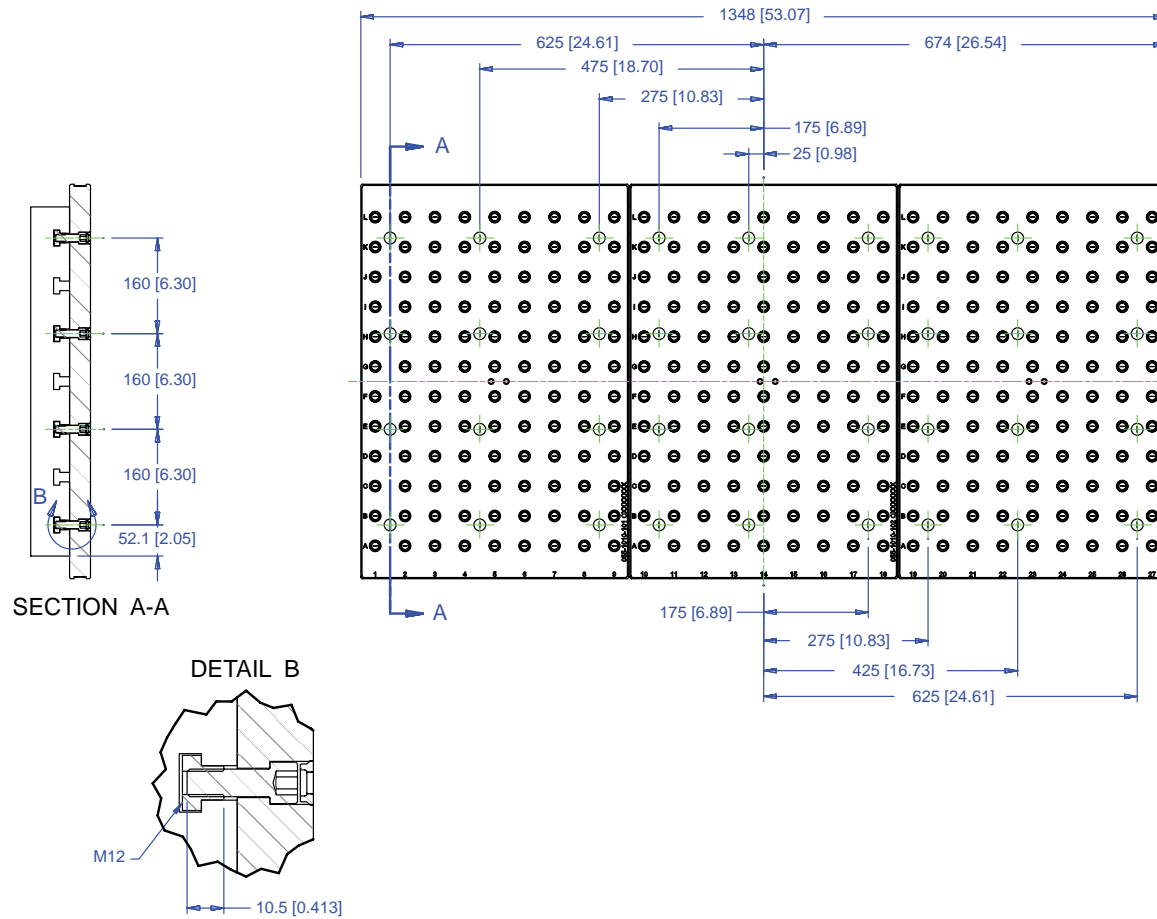

Notes

All dimensions are MM [IN]  
 Maximum number of Qwik-Loks (5QL1040-AL 3 systems Max) (5QL1540-AL 5 systems Max).

**CHICK WORKHOLDING SOLUTIONS, INC.**  
 500 Keystone Drive • Warrendale, PA 15086 USA  
 Phone: (724) 772-1644 • Fax: (724) 772-1633  
[www.ChickWorkholding.com](http://www.ChickWorkholding.com)

# 5VP-HAAS-00104

This workholding package is designed for your HAAS VF-5 machining center.

FOUNDATION LENGTH, DEPTH, AND MOUNTING HOLE CONFIGURATION DESIGNED ACCORDING TO MACHINE TOOL SPECIFICATION



FOUNDATION MAT'L: CAST IRON  
FOUNDATION INCLUDES INSTALLATION HARDWARE

### DETAIL A



HOLE SPACING TOLERANCE  
 $\pm 0.02$  TO 500mm  
 $\pm 0.03$  TO 1200mm

### SECTION B-B

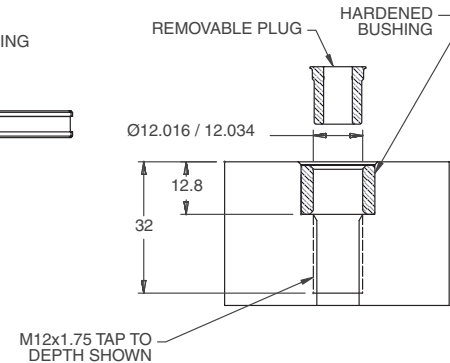

Notes  
All dimensions are MM [IN]

**CHICK WORKHOLDING SOLUTIONS, INC.**  
500 Keystone Drive • Warrendale, PA 15086 USA  
Phone: (724) 772-1644 • Fax: (724) 772-1633  
[www.ChickWorkholding.com](http://www.ChickWorkholding.com)