

PARTS LIST						
No	QTY	PN	ITEM	TYPE	FAM	STYLE
1	1	050-2-10094	KIT	FOUNDATION MOUNTING	5/8" SLOT	(12) 1/2-13 X 1.25" SHCS
2	1	055-1452-01	FOUNDATION ASSY	WP STANDARD	HAAS DT-1_M	748 X 406
3	2	058-9-10001	MPIN12S	ROUND & DIAMOND PIN SET	SYSTEM 5 & M SYSTEM	12mm DIA. x 19mm LONG
4	2	106-9-10003	5QL1040-AL	ALUMINUM QWIK-LOK	5-1040	SHIPPING GROUP
5	1	990-50-021	PACKAGING	SHIPPING CRATE	FOUNDATIONS	36" X 36"

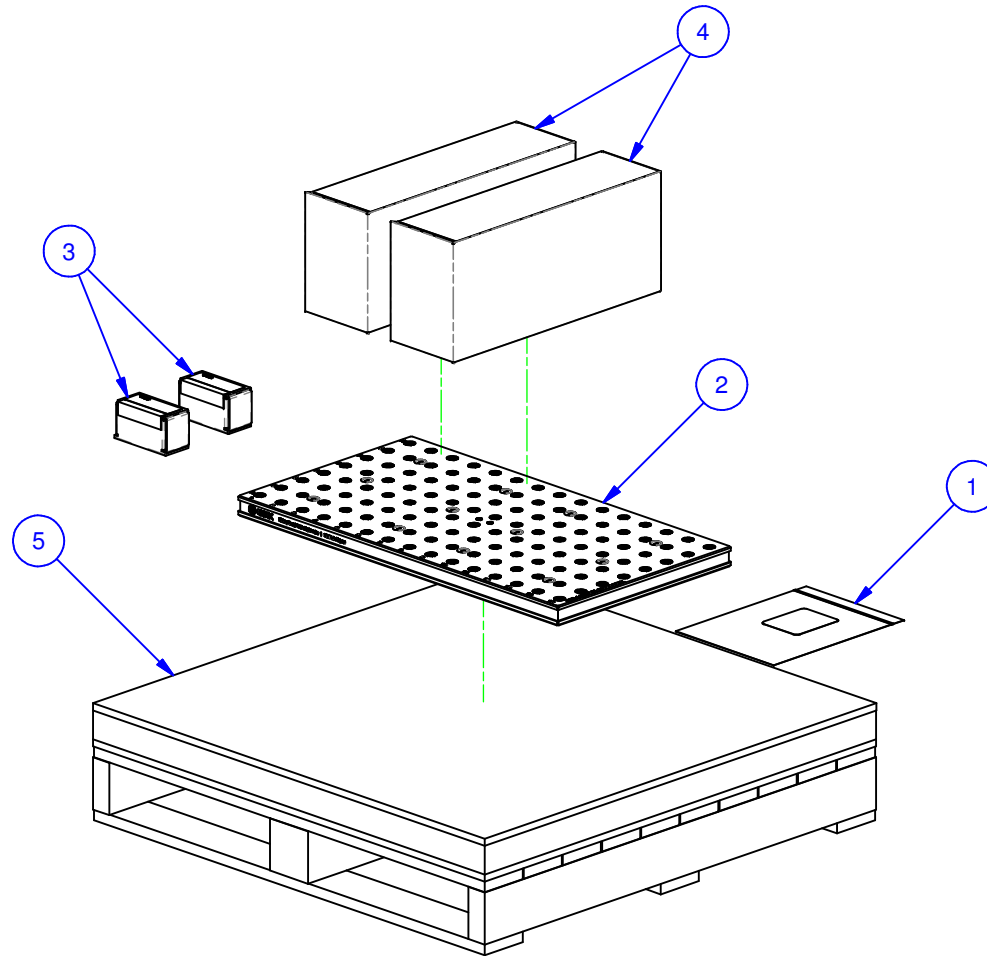

MATERIAL: NA
HARDNESS: NA
COATING: NA
WEIGHT: 111214 g
COMMENTS: UP TO (5) 5QL1040-AL'S MAY BE USED

UNSPECIFIED TOLERANCES:
 X ±0.2
 X.X ±0.1
 X.XX ±0.05
 ANGLES ±0.5°
 ALL DIMENSIONS ARE MILLIMETERS.

CHICK (800) 332-4425
 (724) 772-1644
www.ChickWorkholding.com

UNSPECIFIED EDGES: BREAK 0.3 TO 0.8
 UNSPECIFIED FILLETS: RADIUS 0.3 MAX

ITEM: WORK PKG - VMC		REV A
TYPE: HAAS DT-1_I		
FAM: 5QL1040-AL		SVP-HAAS-00429
STYLE: 748 X 406		
TDD	1 OF 3	
11/1/2011		

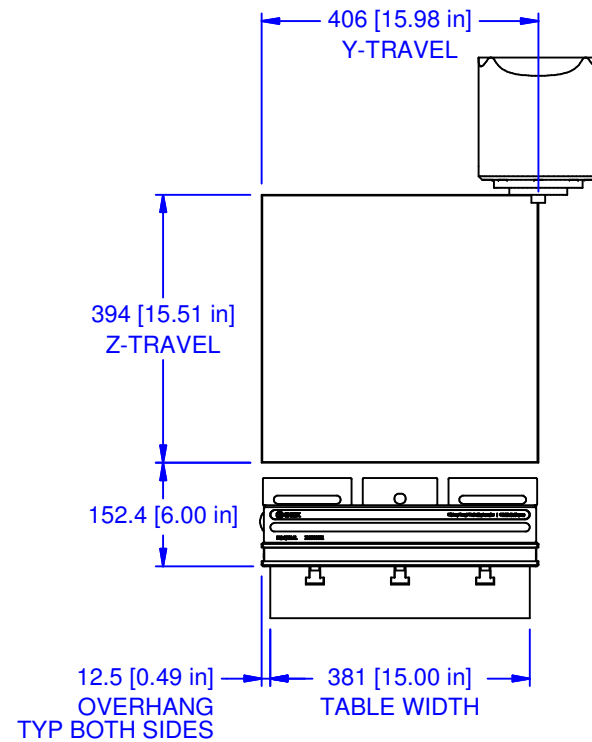
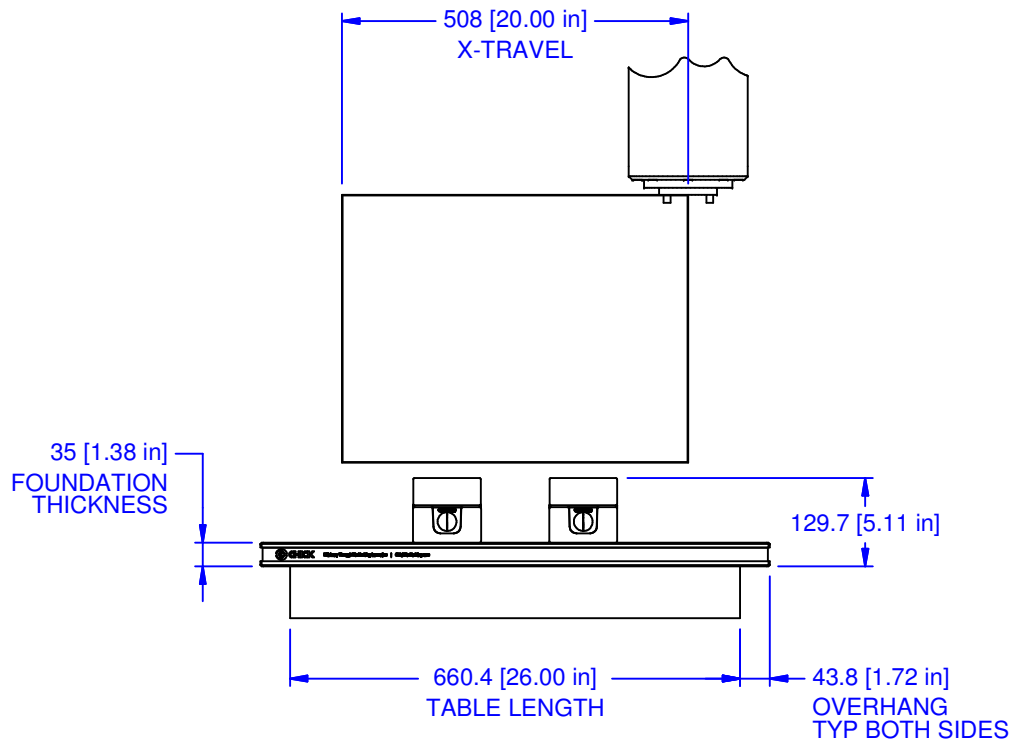
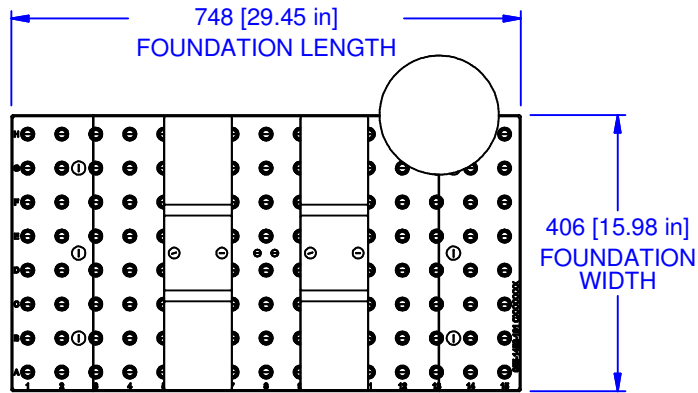

MATERIAL: NA
HARDNESS: NA
COATING: NA
WEIGHT: 111214 g
COMMENTS: UP TO (5) 5QL1040-AL'S MAY BE USED

UNSPECIFIED TOLERANCES:	
X	±0.2
X.X	±0.1
X.XX	±0.05
ANGLES	±0.5°
ALL DIMENSIONS ARE MILLIMETERS.	

CHICK (800) 332-4425
(724) 772-1644
www.ChickWorkholding.com

UNSPECIFIED EDGES: BREAK 0.3 TO 0.8
UNSPECIFIED FILLETS: RADIUS 0.3 MAX

ITEM: WORK PKG - VMC	
TYPE: HAAS DT-1_I	
FAM: 5QL1040-AL	
STYLE: 748 X 406	
TDD	2 OF 3
11/1/2011	5VP-HAAS-00429
	REV A

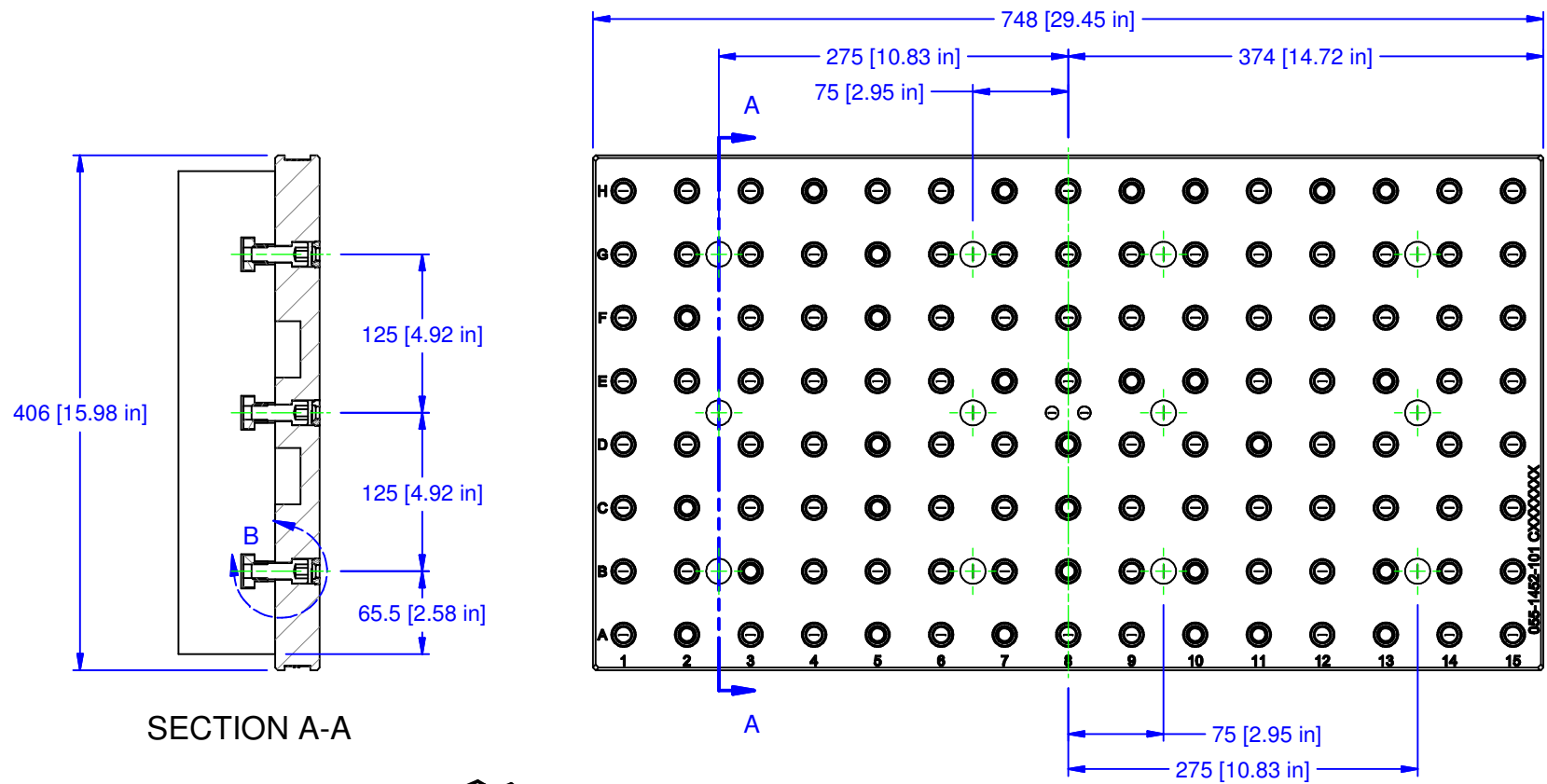

SECTION A-A

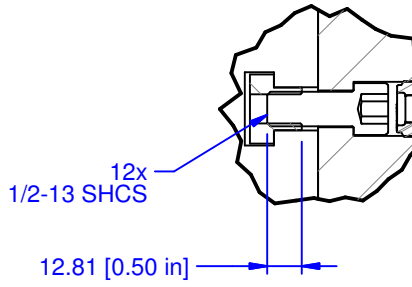

DETAIL B

MATERIAL: NA
HARDNESS: NA
COATING: NA
WEIGHT: 111214 g
COMMENTS: UP TO (5) 5QL1040-AL'S MAY BE USED

UNSPECIFIED TOLERANCES:

X	±0.2
X.X	±0.1
X.XX	±0.05
ANGLES	±0.5°

ALL DIMENSIONS ARE MILLIMETERS.

CHICK (800) 332-4425
 (724) 772-1644
www.ChickWorkholding.com

UNSPECIFIED EDGES: BREAK 0.3 TO 0.8
 UNSPECIFIED FILLETS: RADIUS 0.3 MAX

ITEM: WORK PKG - VMC	
TYPE: HAAS DT-1_I	
FAM: 5QL1040-AL	
STYLE: 748 X 406	
TDD	3 OF 3
11/1/2011	5VP-HAAS-00429
	REV A