

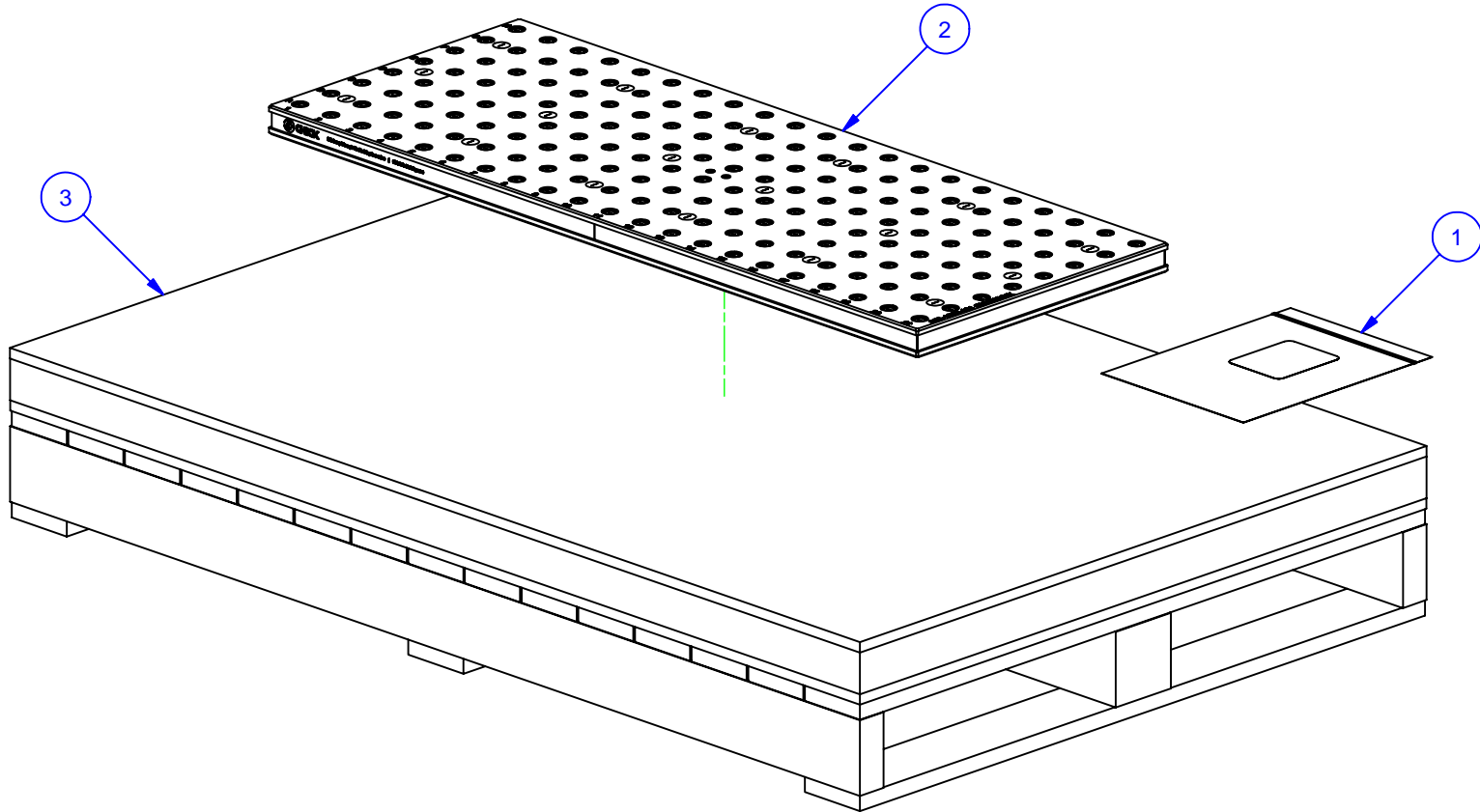

PARTS LIST						
No	QTY	PN	ITEM	TYPE	FAM	STYLE
1	1	050-2-10060	KIT	FOUNDATION MOUNTING	5/8" T-SLOT	(18) 1/2-13 X 1.5" SHCS
2	1	055-1379-01	FOUNDATION ASSY	WP STANDARD	HAAS MINI-MILL 2	1048 X 406
3	1	990-50-022	PACKAGING	SHIPPING CRATE	FOUNDATIONS	54" X 36"



MATERIAL: NA	UNSPECIFIED TOLERANCES: X ±0.2 X.X ±0.1 X.XX ±0.05 ANGLES ±0.5° ALL DIMENSIONS ARE MILLIMETERS.	 (800) 332-4425 (724) 772-1644 www.ChickWorkholding.com	ITEM: WORK PKG - VMC	TDD 1 OF 3 5/18/2010	5VP-HAAS-00435 A
HARDNESS: NA			TYPE: HAAS MINI-MILL 2_I		
COATING: NA			FAM: FOUNDATION ONLY		
WEIGHT: 148608 g			STYLE: 1048 X 406	UNSPECIFIED EDGES: BREAK 0.3 TO 0.8	UNSPECIFIED FILLETS: RADIUS 0.3 MAX
COMMENTS:					

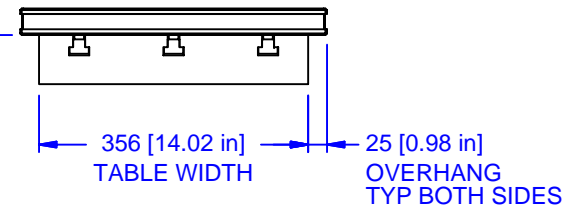
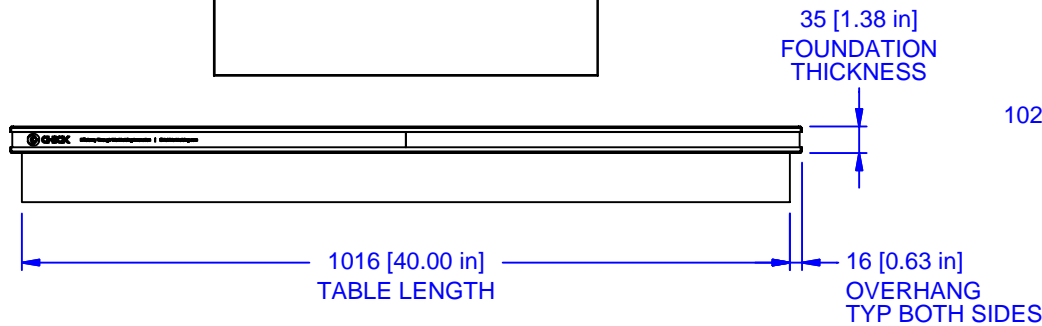
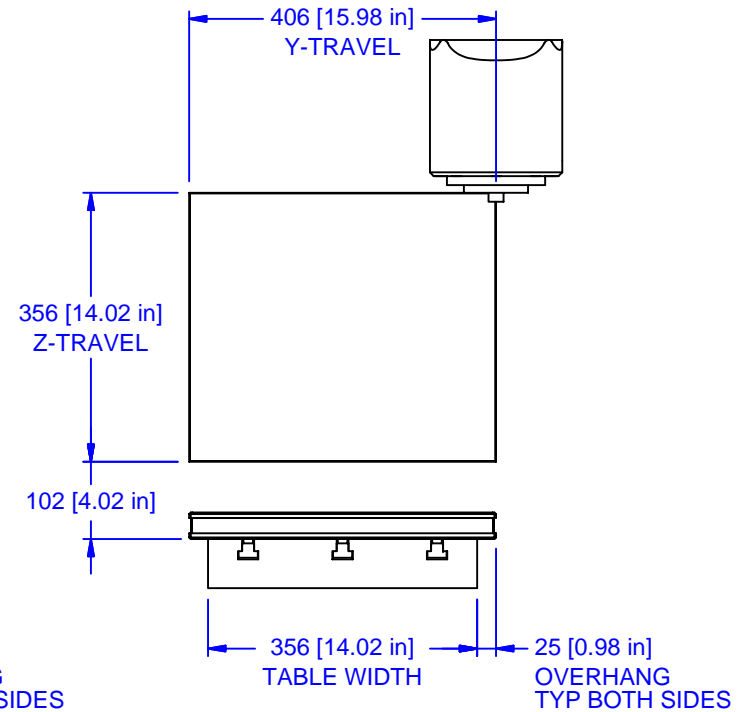
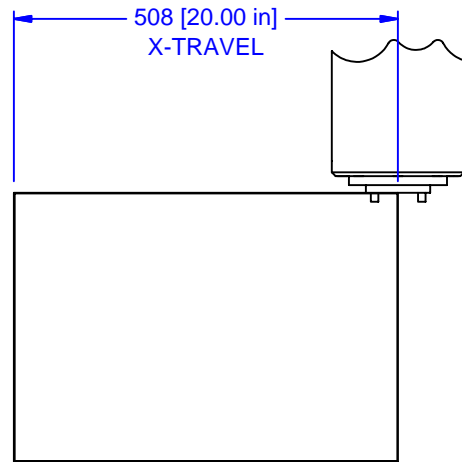
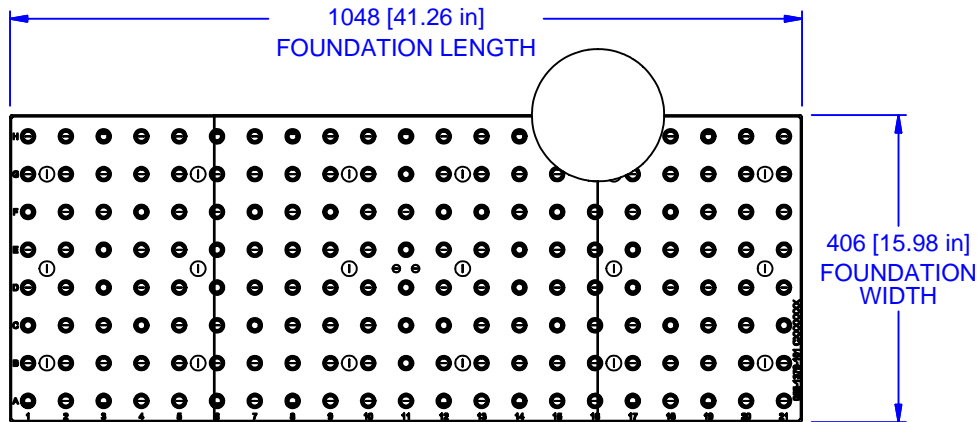

MATERIAL:	NA
HARDNESS:	NA
COATING:	NA
WEIGHT:	148608 g
COMMENTS:	

UNSPECIFIED TOLERANCES:	
X	±0.2
X.X	±0.1
X.XX	±0.05
ANGLES	±0.5°
ALL DIMENSIONS ARE MILLIMETERS.	

CHICK (800) 332-4425
(724) 772-1644
www.ChickWorkholding.com

UNSPECIFIED EDGES: BREAK 0.3 TO 0.8
UNSPECIFIED FILLETS: RADIUS 0.3 MAX

ITEM:	WORK PKG - VMC		
TYPE:	HAAS MINI-MILL 2_I		
FAM:	FOUNDATION ONLY		
STYLE:	1048 X 406		
TDD	2 OF 3	5VP-HAAS-00435	REV A
5/18/2010			

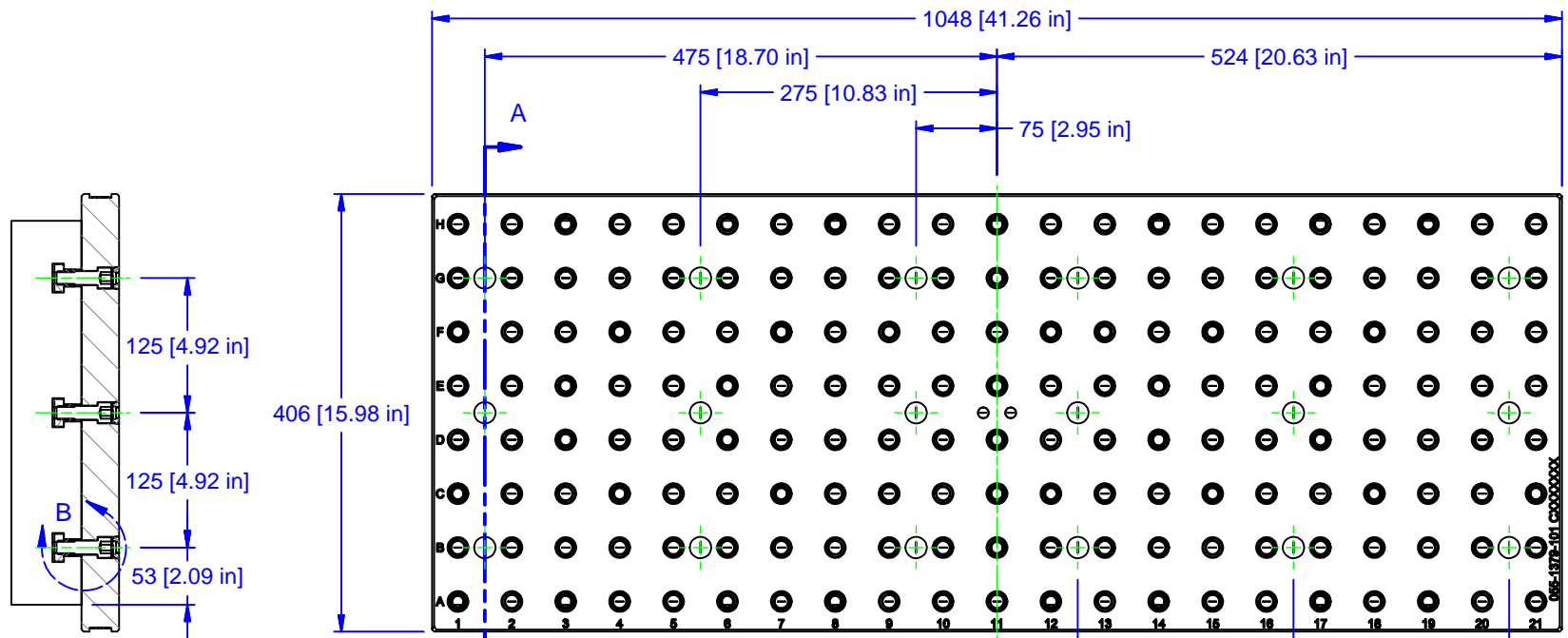

SECTION A-A

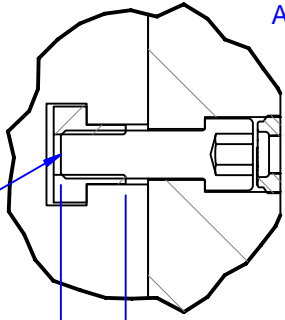
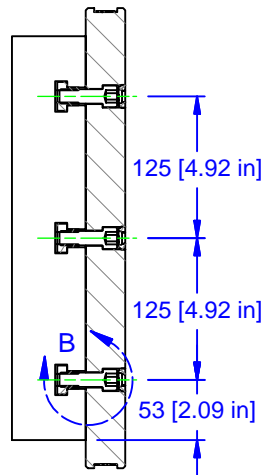

DETAIL B

18x
1/2-13 SHCS / 5/8" T-NUT

MATERIAL:	NA
HARDNESS:	NA
COATING:	NA
WEIGHT:	148608 g
COMMENTS:	

UNSPECIFIED TOLERANCES:
 X ±0.2
 X.X ±0.1
 X.XX ±0.05
 ANGLES ±0.5°
 ALL DIMENSIONS ARE MILLIMETERS.

CHICK (800) 332-4425
 (724) 772-1644
www.ChickWorkholding.com
 UNSPECIFIED EDGES: BREAK 0.3 TO 0.8
 UNSPECIFIED FILLETS: RADIUS 0.3 MAX

ITEM: WORK PKG - VMC		REV A
TYPE: HAAS MINI-MILL 2_I		
FAM: FOUNDATION ONLY		5VP-HAAS-00435
STYLE: 1048 X 406		
TDD	3 OF 3	
5/18/2010		