

PARTS LIST						
No	QTY	PN	ITEM	TYPE	FAM	STYLE
1	4	050-2-10002	KIT	FOUNDATION MOUNTING	5/8" T-SLOT	(12) 1/2-13 X 1.5" SHCS
2	1	050-2-90001	KIT	FOUNDATION ALIGNMENT	STANDARD GRID	50mm SEAM
3	1	055-1203-01	FOUNDATION ASSEMBLY	WP STANDARD	HAAS VF-9	548 X 1014 (LEFT PLATE)
4	1	055-1203-02	FOUNDATION ASSEMBLY	WP STANDARD	HAAS VF-9	548 X 1014 (LEFT MID PLATE)
5	1	055-1203-03	FOUNDATION ASSEMBLY	WP STANDARD	HAAS VF-9	498 X 1014 (RIGHT MID PLATE)
6	1	055-1203-04	FOUNDATION ASSEMBLY	WP STANDARD	HAAS VF-9	548 X 1014 (RIGHT PLATE)
7	2	156-9-10003	5QL1550-AL	ALUMINUM QWIK-LOK	5-1550	SHIPPING GROUP
8	4	990-50-022	PACKAGING	SHIPPING CRATE	FOUNDATIONS	54" X 36"

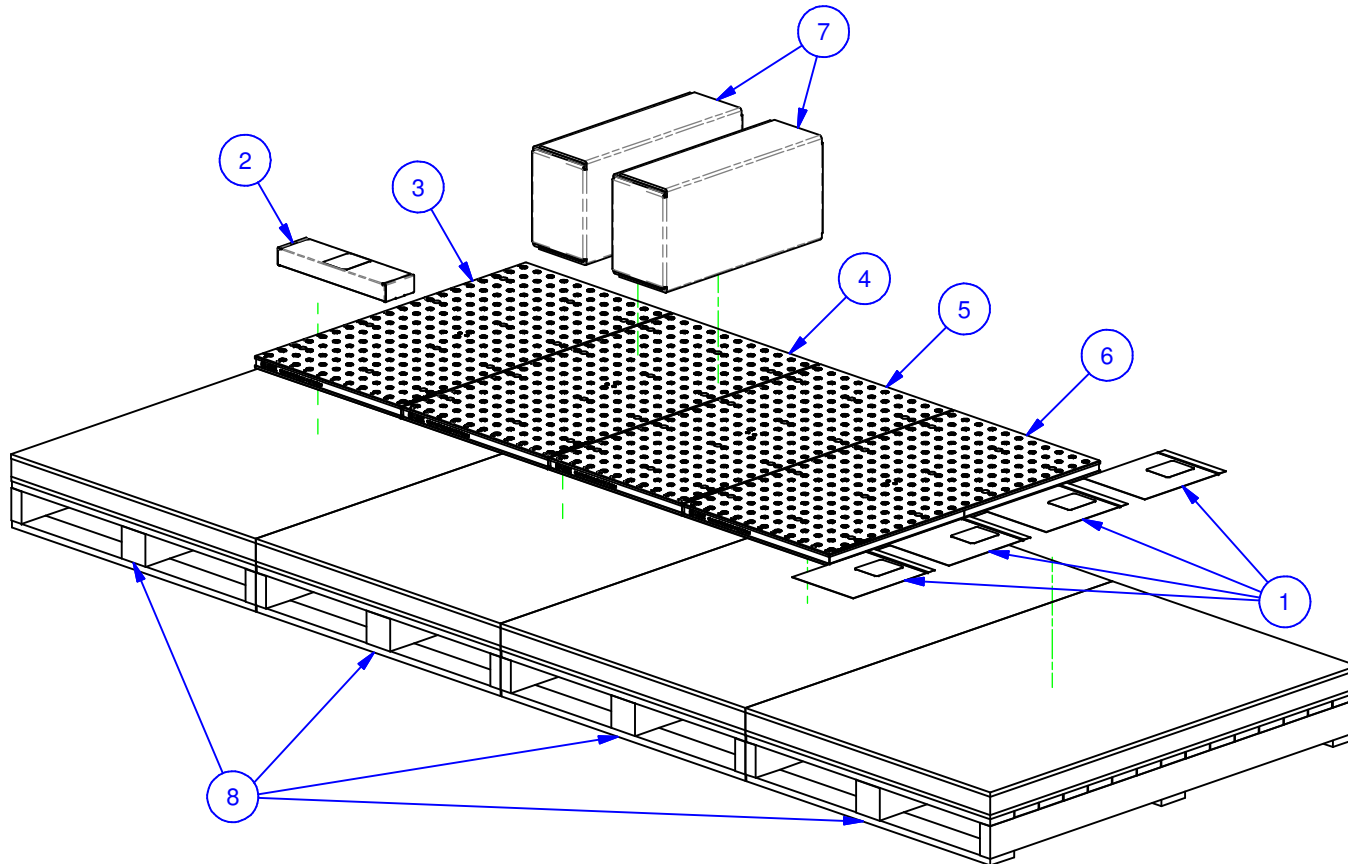

MATERIAL: NA
HARDNESS: NA
COATING: NA
WEIGHT: 768083 g
COMMENTS: UP TO (14) 5QL1550-AL'S MAY BE USED

UNSPECIFIED TOLERANCES:	
X	±0.2
X.X	±0.1
X.XX	±0.05
ANGLES	±0.5°
ALL DIMENSIONS ARE MILLIMETERS.	

 (800) 332-4425
 (724) 772-1644
www.ChickWorkholding.com

UNSPECIFIED EDGES: BREAK 0.3 TO 0.8
 UNSPECIFIED FILLETS: RADIUS 0.3 MAX

ITEM: WORK PKG - VMC	
TYPE: HAAS VF-9_I	
FAM: 5QL1550-AL	
STYLE: 2148 X 1014	
TDD	1 OF 3
4/27/2011	SVP-HAAS-00258
	REV A

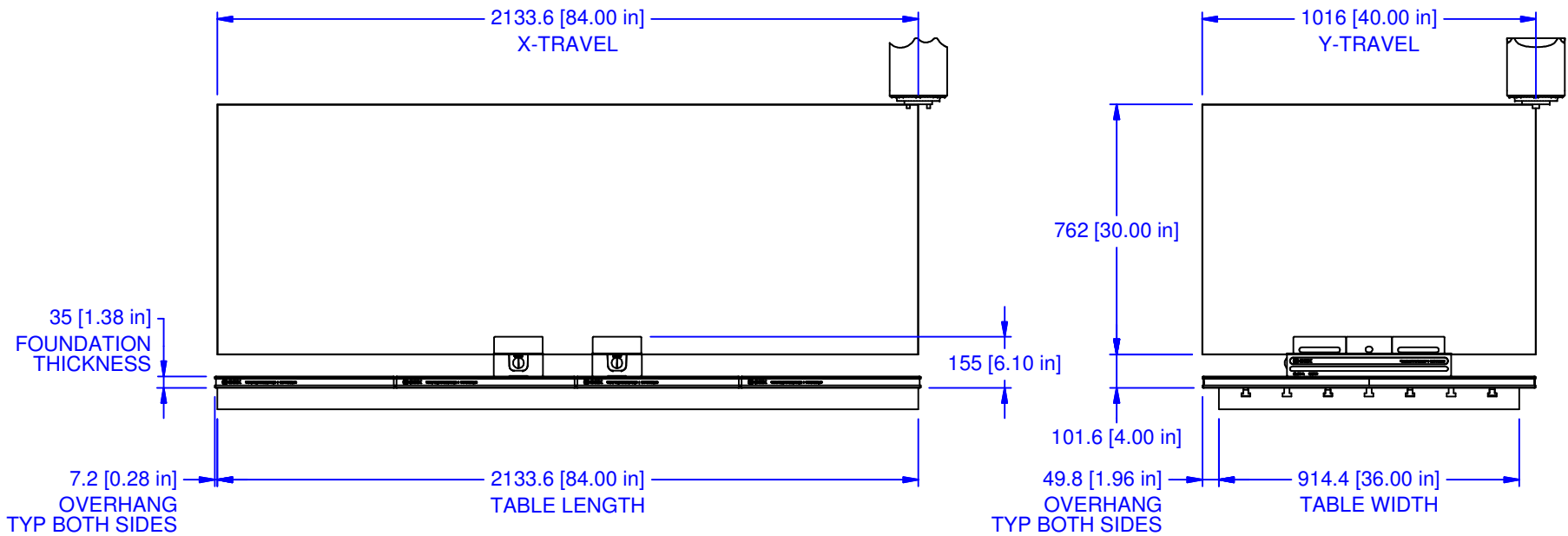
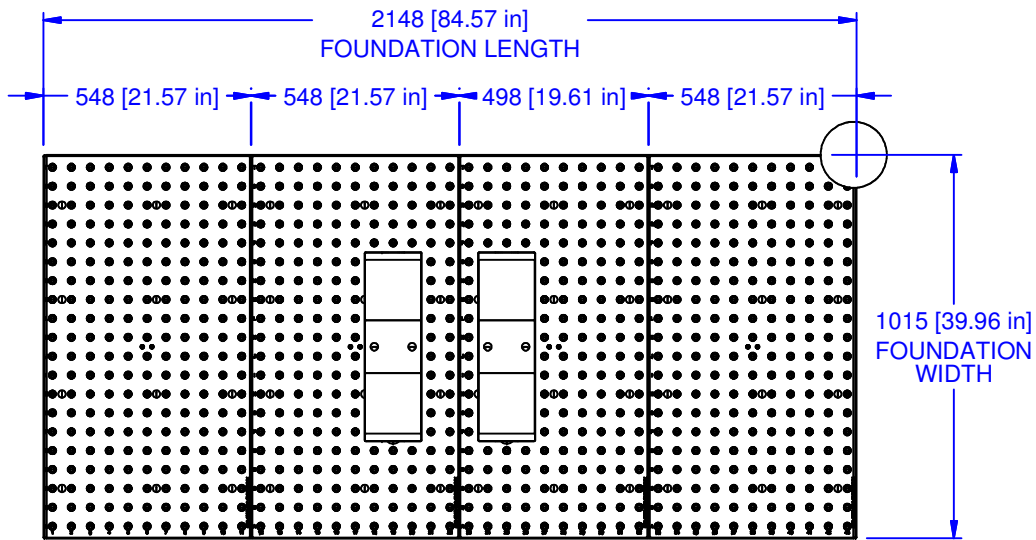

MATERIAL: NA
HARDNESS: NA
COATING: NA
WEIGHT: 768083 g
COMMENTS: UP TO (14) 5QL1550-AL'S MAY BE USED

UNSPECIFIED TOLERANCES:	
X	±0.2
X.X	±0.1
X.XX	±0.05
ANGLES	±0.5°
ALL DIMENSIONS ARE MILLIMETERS.	

CHICK (800) 332-4425
(724) 772-1644
www.ChickWorkholding.com

UNSPECIFIED EDGES: BREAK 0.3 TO 0.8
UNSPECIFIED FILLETS: RADIUS 0.3 MAX

ITEM: WORK PKG - VMC	
TYPE: HAAS VF-9_I	
FAM: 5QL1550-AL	
STYLE: 2148 X 1014	
TDD	2 OF 3
4/27/2011	SVP-HAAS-00258
REV	A

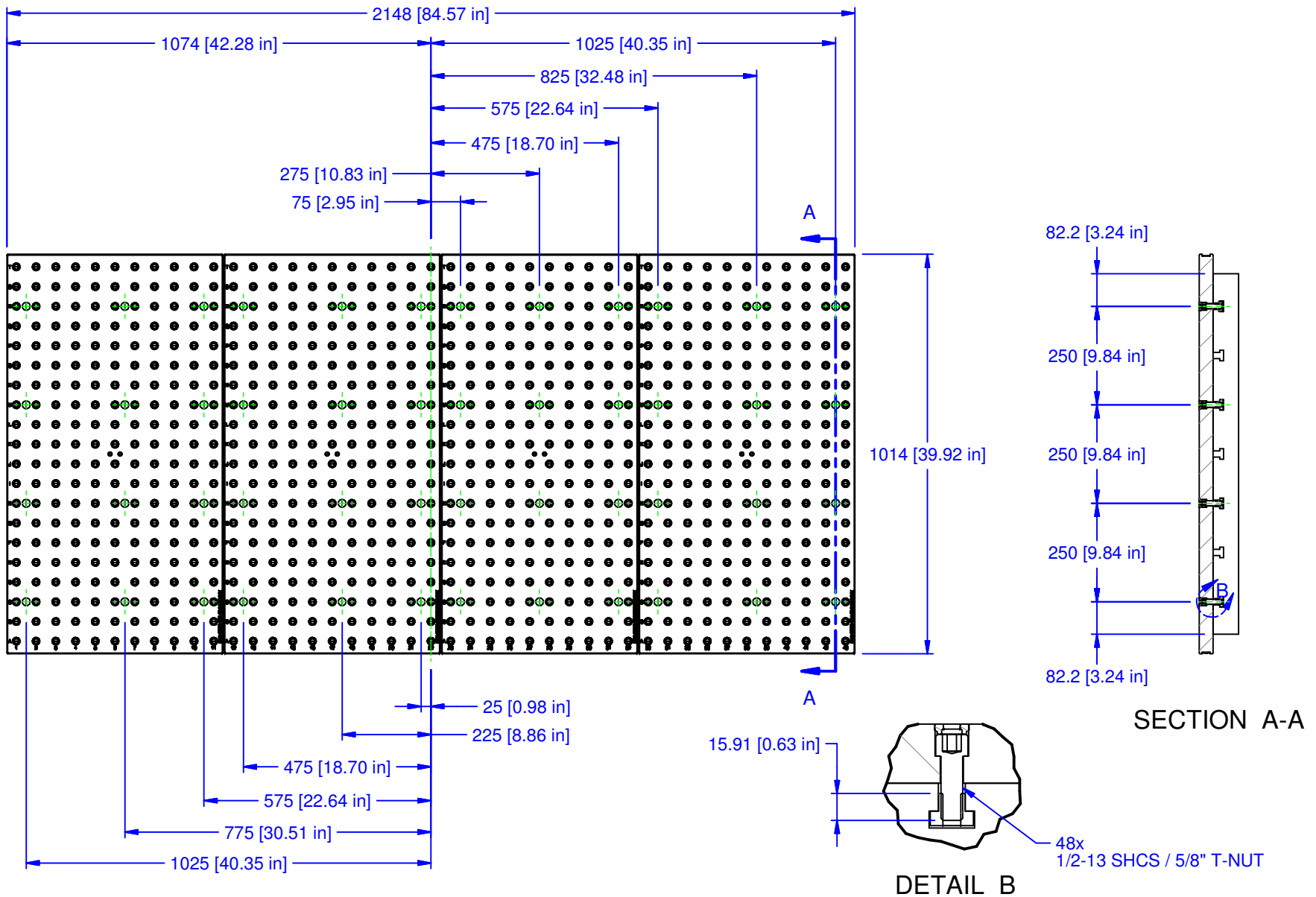

MATERIAL:	NA
HARDNESS:	NA
COATING:	NA
WEIGHT:	768083 g
COMMENTS:	UP TO (14) 5QL1550-AL'S MAY BE USED

UNSPECIFIED TOLERANCES:

X	±0.2
X.X	±0.1
X.XX	±0.05
ANGLES	±0.5°

ALL DIMENSIONS ARE MILLIMETERS.

CHICK (800) 332-4425
 (724) 772-1644
www.ChickWorkholding.com

UNSPECIFIED EDGES: BREAK 0.3 TO 0.8
 UNSPECIFIED FILLETS: RADIUS 0.3 MAX

ITEM: WORK PKG - VMC		REV A
TYPE: HAAS VF-9_I		
FAM: 5QL1550-AL		5VP-HAAS-00258
STYLE: 2148 X 1014		
TDD	3 OF 3	
4/27/2011		