

CUSTOMER DRAWING

SHIPPING ARRANGEMENT

CHICK (800) 332-4425
 (724) 772-1644
 www.ChickWorkholding.com

WORK PKG - VMC
 HURCO VM10i
 5QL1040-AL
 848 X 452

TDD	1 OF 3	5VP-HURC-00076 CD	REV
4/17/2019			A

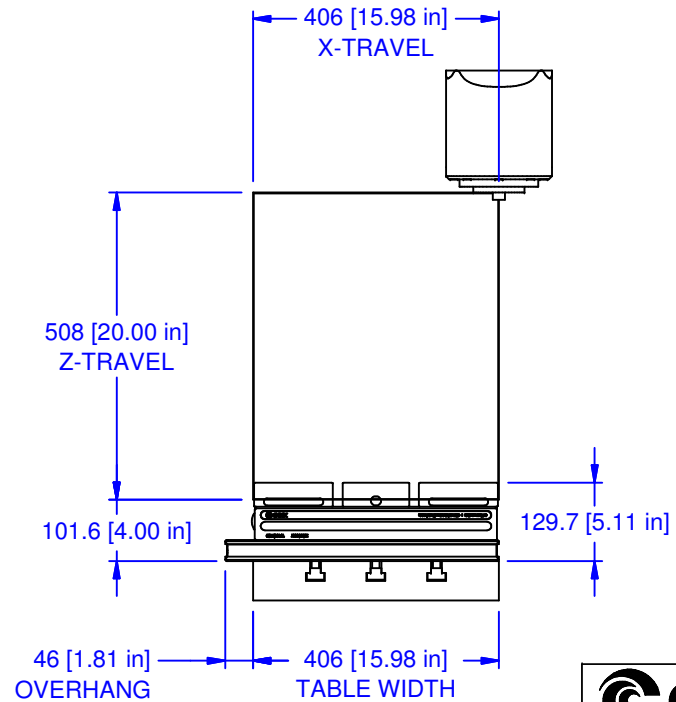
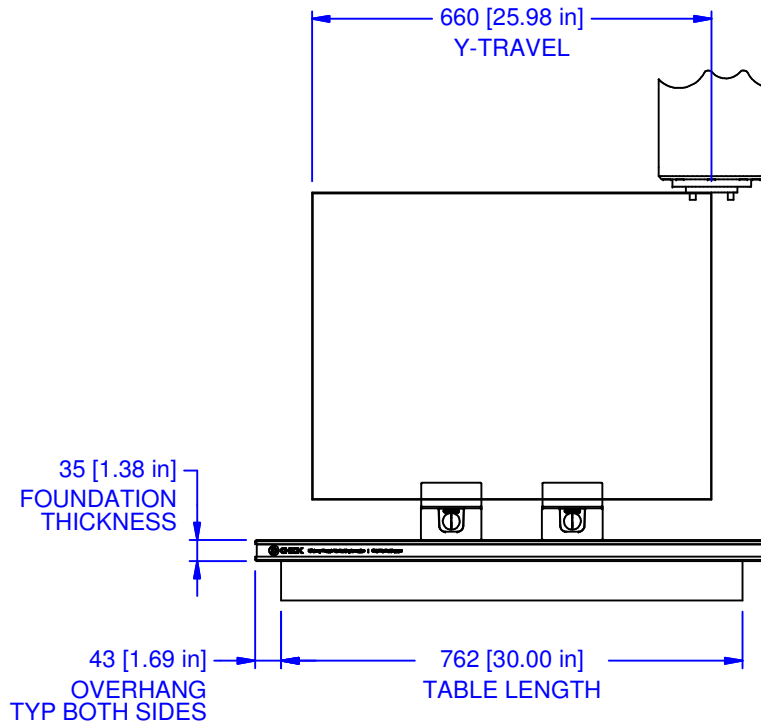
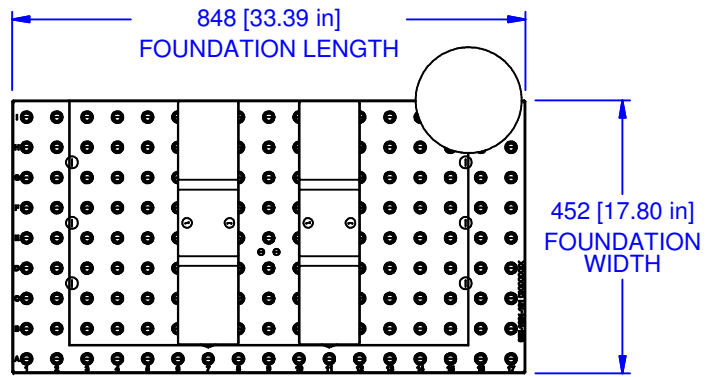

WORK ENVELOPE

CHICK (800) 332-4425
(724) 772-1644
www.ChickWorkholding.com

WORK PKG - VMC
HURCO VM10i
5QL1040-AL
848 X 452

TDD	2 OF 3	SVP-HURC-00076 CD	REV
4/17/2019			A

CUSTOMER DRAWING

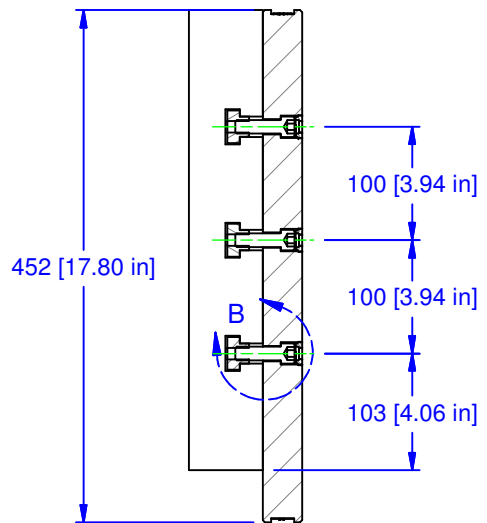

SECTION A-A

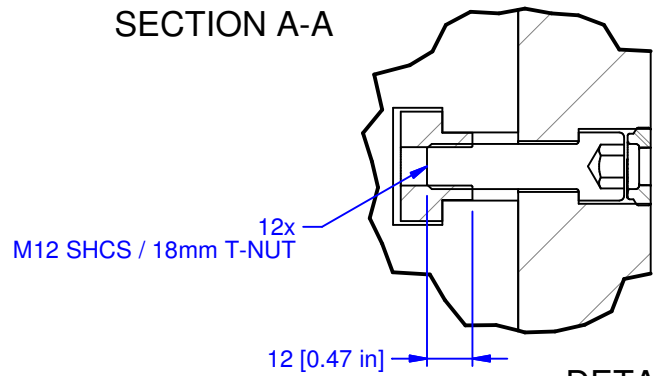
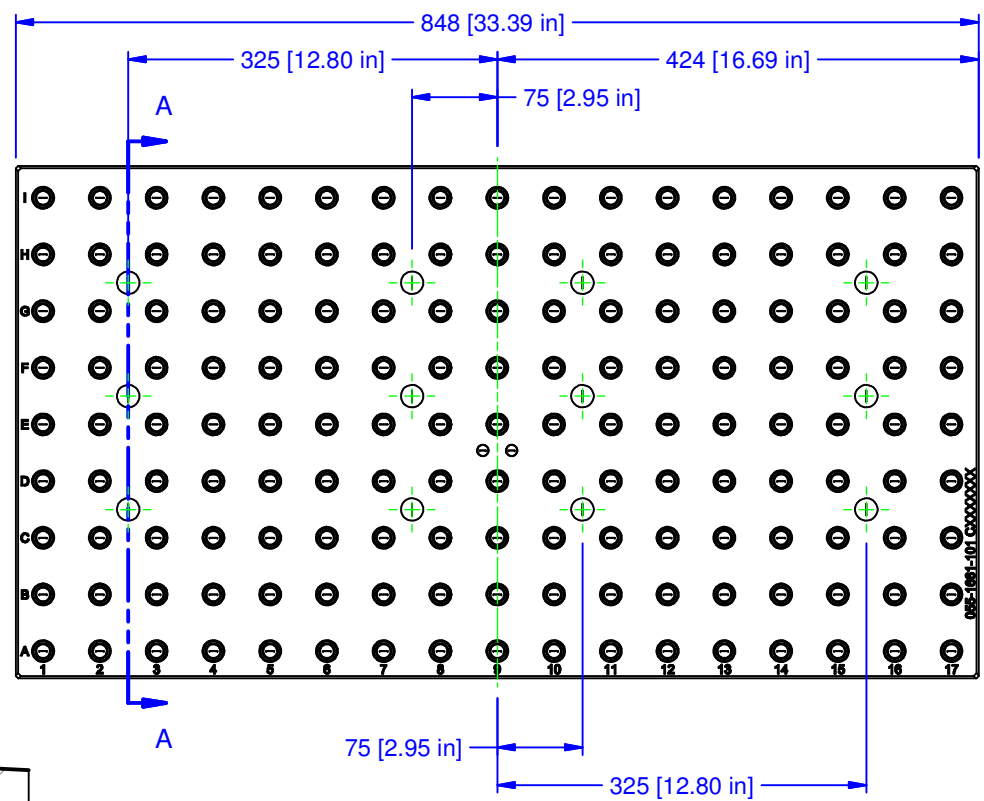

DETAIL B

NOTES:

EACH HOLE IN THE GRID PATTERN IS BUSHED WITH A Ø12 (ID) x 12 LONG BUSHING AND TAPPED WITH AN M12x1.75 THREAD

INSTALLED IN EACH HOLE IS A REMOVABLE PLUG

FOUNDATIONS ARE MADE FROM CAST IRON

CUSTOMER DRAWING

TABLE INTERFACE

CHICK (800) 332-4425
 (724) 772-1644
 www.ChickWorkholding.com

WORK PKG - VMC
 HURCO VM10i
 5QL1040-AL
 848 X 452

TDD	3 OF 3	5VP-HURC-00076 CD	REV
4/17/2019			A