

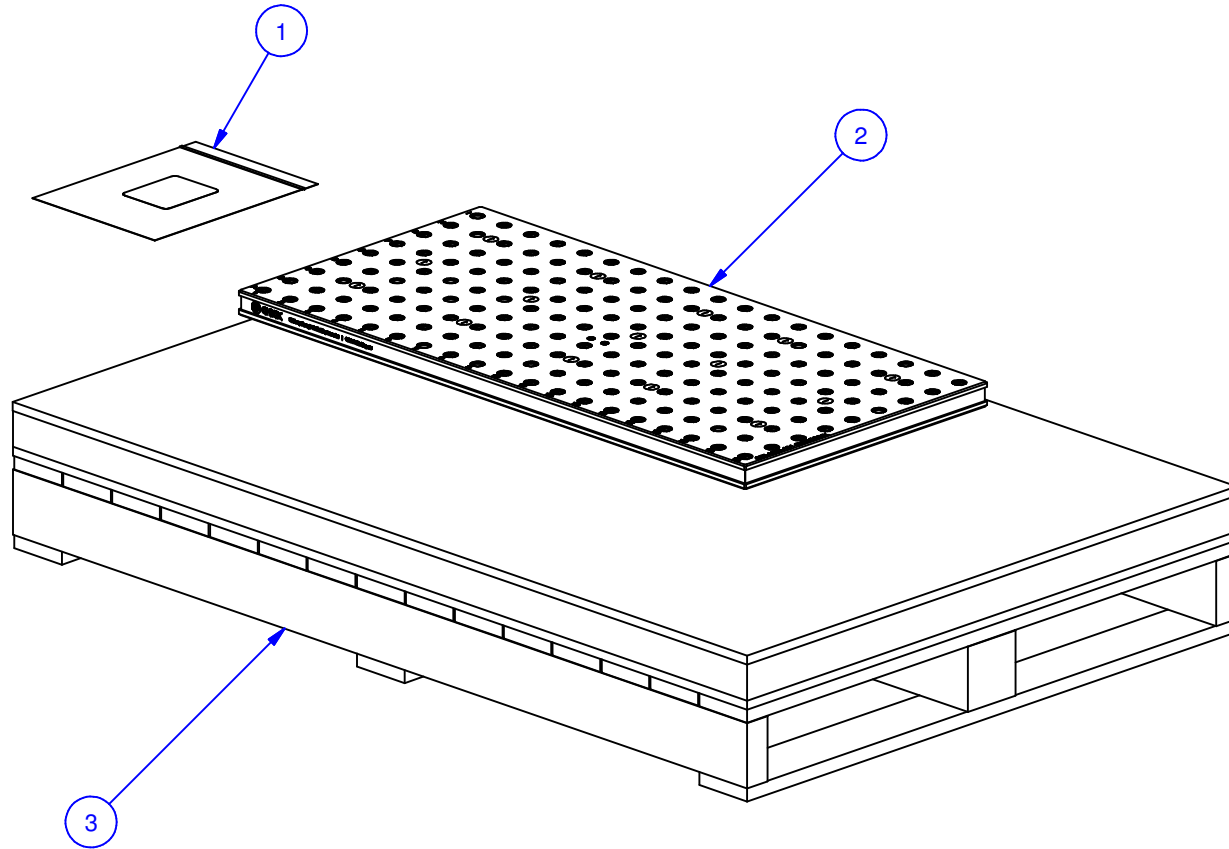

PARTS LIST						
No	QTY	PN	ITEM	TYPE	FAM	STYLE
1	1	050-2-10025	KIT	FOUNDATION MOUNTING	14mm T-SLOT	(15) M12 X 35 SHCS
2	1	055-1034-01	FOUNDATION ASSY	WP STANDARD	FANUC ROBODRILL T21-iEL	948 X 454
3	1	990-50-022	PACKAGING	SHIPPING CRATE	FOUNDATIONS	54" X 36"



MATERIAL: NA	UNSPECIFIED TOLERANCES: X ±0.2 X.X ±0.1 X.XX ±0.05 ANGLES ±0.5° ALL DIMENSIONS ARE MILLIMETERS.	 (800) 332-4425 (724) 772-1644 <a href="http://www.ChickWorkholding.com">www.ChickWorkholding.com</a>	ITEM: WORK PKG - VMC			
HARDNESS: NA			TYPE: FANUC ROBODRILL T21iEL(iBL)			
COATING: NA			FAM: FOUNDATION			
WEIGHT: 149204 g			STYLE: 948 X 454			
COMMENTS:			BSM	1 OF 3	5VP-ROBO-00009	REV A
			2/18/2011			

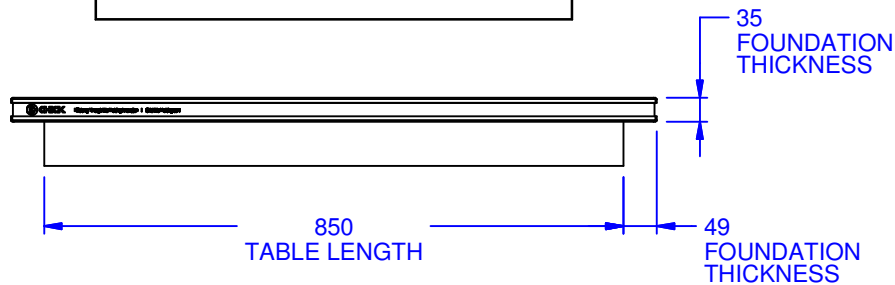
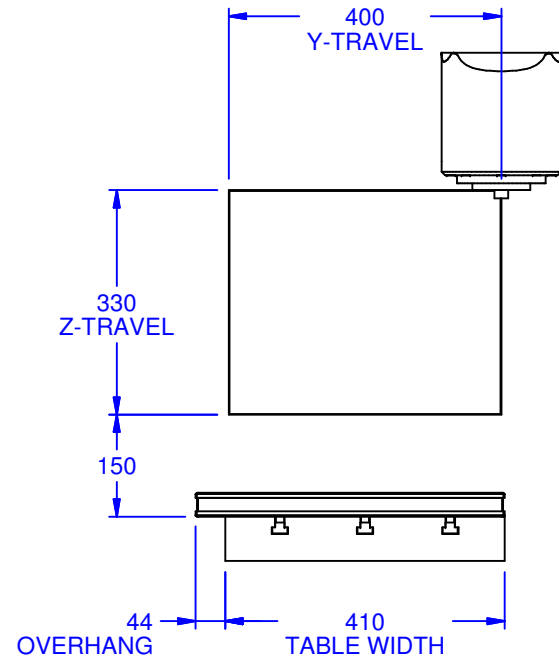
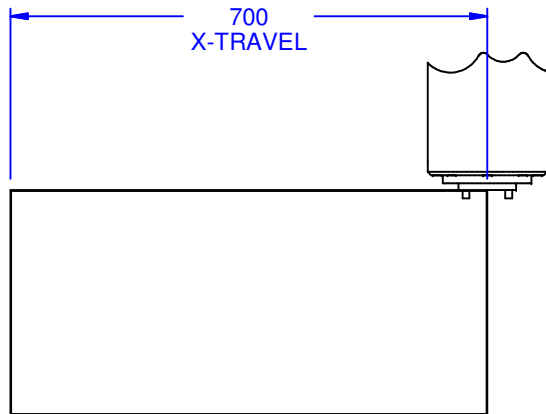
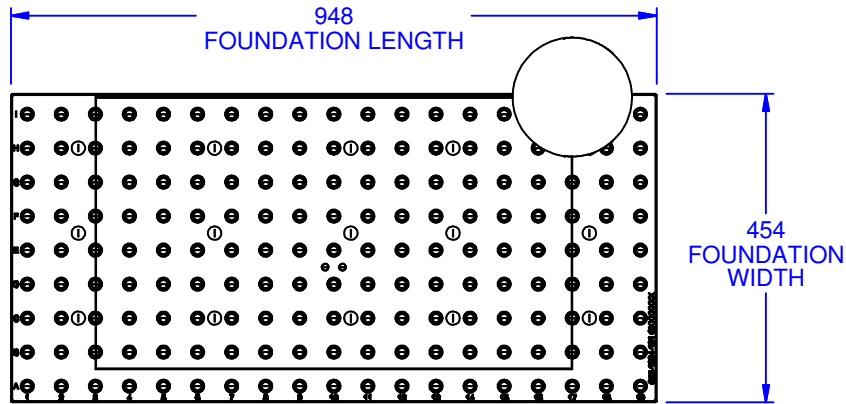

MATERIAL: <b>NA</b>
HARDNESS: <b>NA</b>
COATING: <b>NA</b>
WEIGHT: <b>149204 g</b>
COMMENTS:

UNSPECIFIED TOLERANCES:  
 X ±0.2  
 X.X ±0.1  
 X.XX ±0.05  
 ANGLES ±0.5°  
 ALL DIMENSIONS ARE MILLIMETERS.

**CHICK** (800) 332-4425  
 (724) 772-1644  
[www.ChickWorkholding.com](http://www.ChickWorkholding.com)

ITEM: <b>WORK PKG - VMC</b>
TYPE: <b>FANUC ROBO DRILL T21iEL(iBL)</b>
FAM: <b>FOUNDATION</b>
STYLE: <b>948 X 454</b>

BSM	2 OF 3	5VP-ROBO-00009	REV A
2/18/2011			

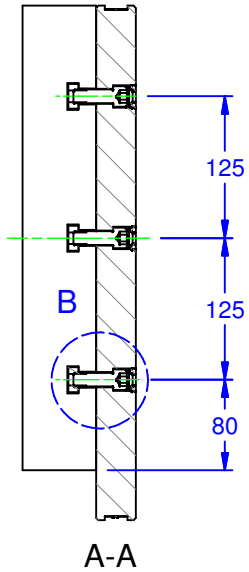

A-A

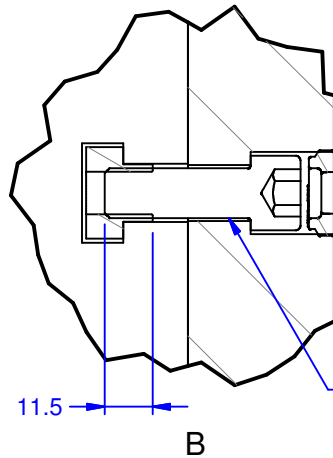

B

15x  
14mm T-NUT / M12 THREAD

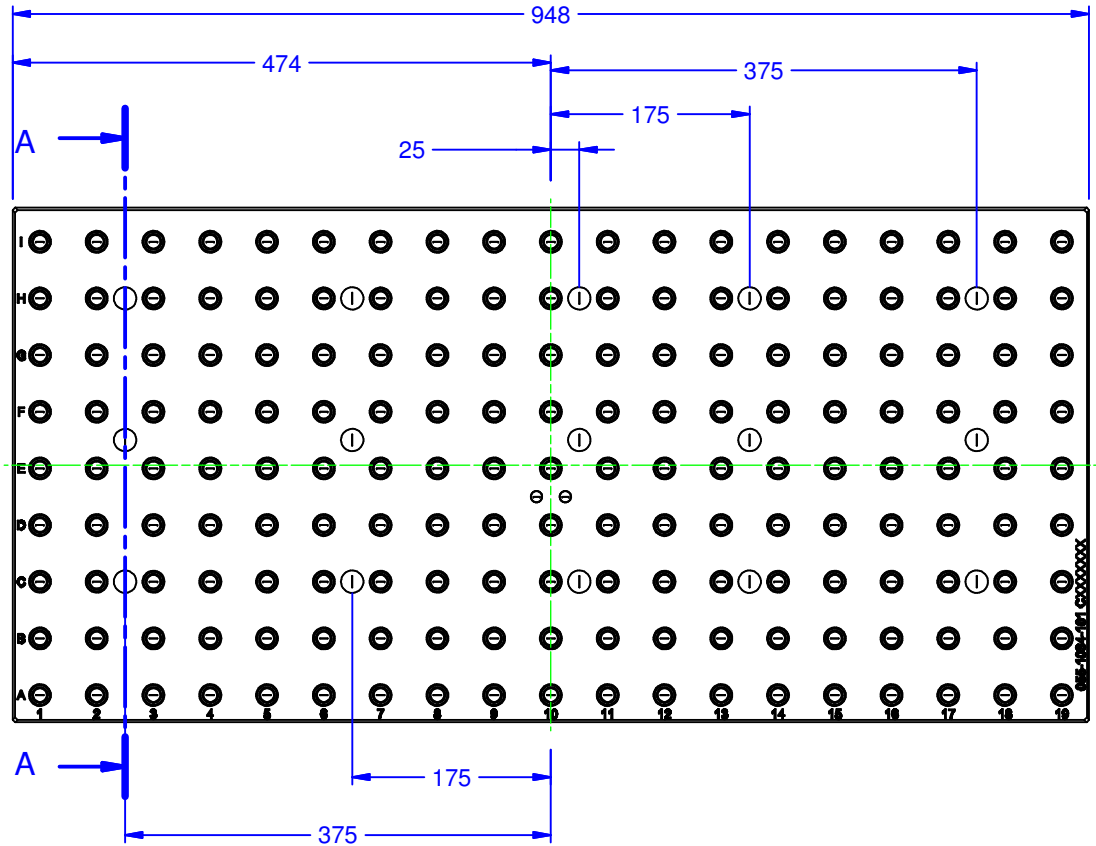

MATERIAL: <b>NA</b>
HARDNESS: <b>NA</b>
COATING: <b>NA</b>
WEIGHT: <b>149204 g</b>
COMMENTS:

UNSPECIFIED TOLERANCES:  
 X ±0.2  
 X.X ±0.1  
 X.XX ±0.05  
 ANGLES ±0.5°  
 ALL DIMENSIONS ARE MILLIMETERS.

**CHICK** (800) 332-4425  
 (724) 772-1644  
[www.ChickWorkholding.com](http://www.ChickWorkholding.com)

ITEM: <b>WORK PKG - VMC</b>		REV <b>A</b>
TYPE: <b>FANUC ROBO DRILL T21iEL(iBL)</b>		
FAM: <b>FOUNDATION</b>		5VP-ROBO-00009
STYLE: <b>948 X 454</b>		
BSM	3 OF 3	
2/18/2011		