

PARTS LIST						
No	QTY	PN	ITEM	TYPE	FAM	STYLE
1	1	050-2-10025	KIT	FOUNDATION MOUNTING	14mm T-SLOT	(15) M12 X 35 SHCS
2	1	055-1034-01	FOUNDATION ASSY	WP STANDARD	FANUC ROBODRILL T21-iEL	948 X 454
3	1	990-50-002	PACKAGING	WOOD SHIPPING PALLET	36" X 54"	NA
4	2	080-9-10002	081-1205	QWIK-LOK	5-0525	SHIPPING GROUP
5	2	080-9-10003	081-0900	FOUNDATION ADAPTER	5-05	SHIPPING GROUP

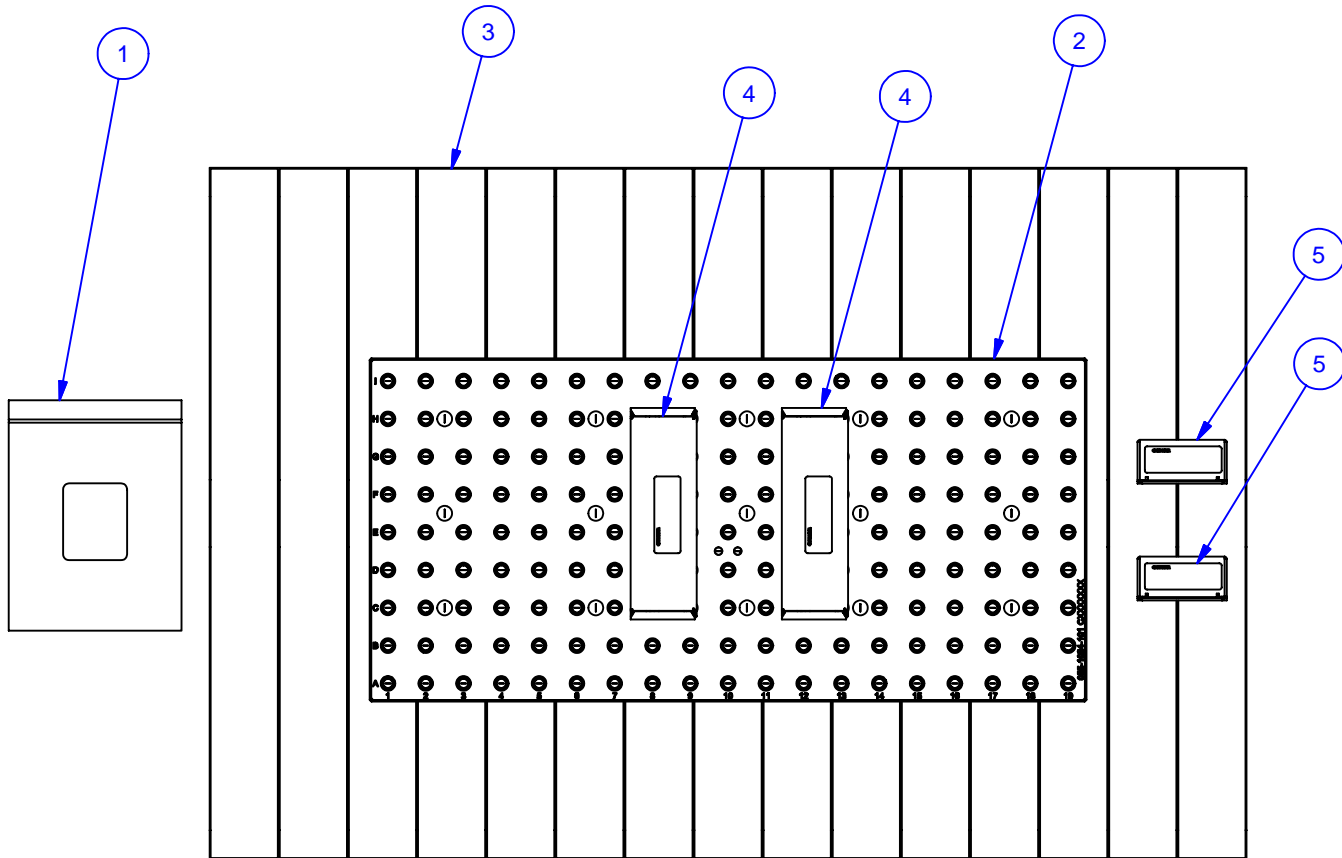

MATERIAL: NA
HARDNESS: NA
COATING: NA
WEIGHT: 134200 g
COMMENTS:

UNSPECIFIED TOLERANCES:
 X ±0.2
 X.X ±0.1
 X.XX ±0.05
 ANGLES ±0.5°
 ALL DIMENSIONS ARE MILLIMETERS.

CHICK (800) 332-4425
 (724) 772-1644
www.ChickWorkholding.com
 UNSPECIFIED EDGES: BREAK 0.3 TO 0.8
 UNSPECIFIED FILLETS: RADIUS 0.3 MAX

ITEM: WORK PKG - VMC	REV
TYPE: FANUC ROBODRILL T21iFL	A
FAM: 081-1205 (2)	
STYLE: 948 X 454 FOUNDATION	
BCE	1 OF 3
10/30/2007	5VP-ROBO-00047

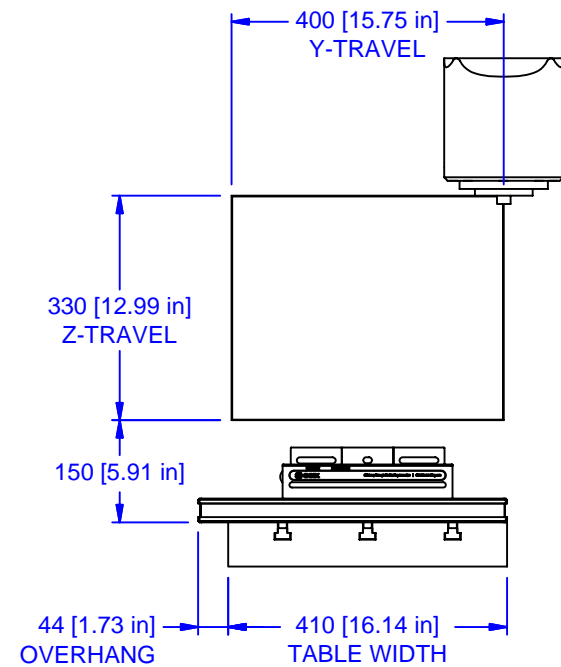
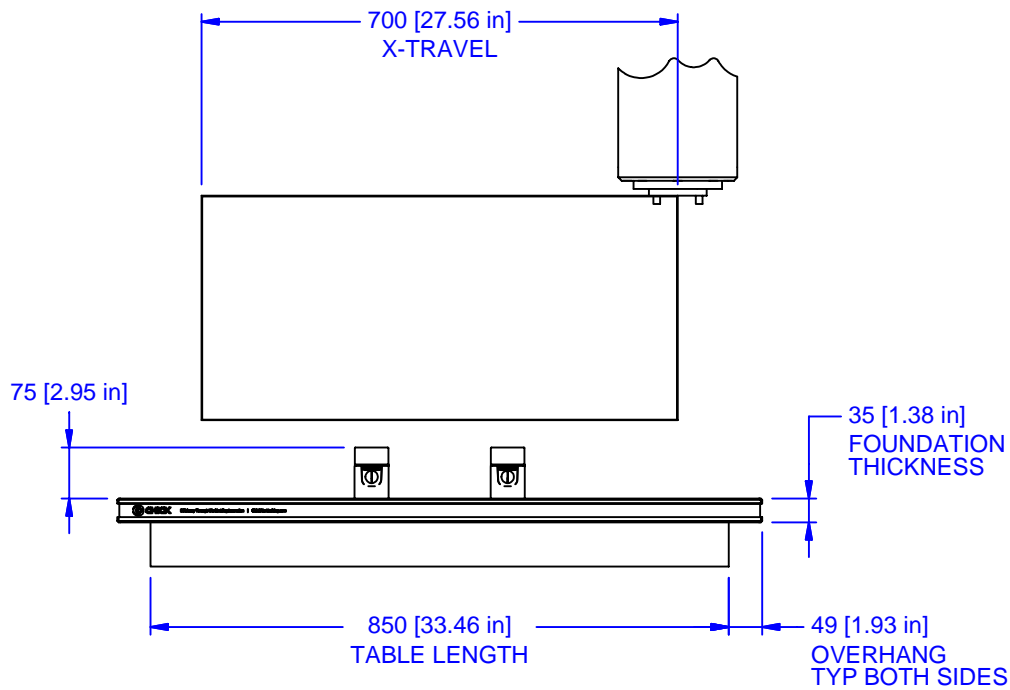
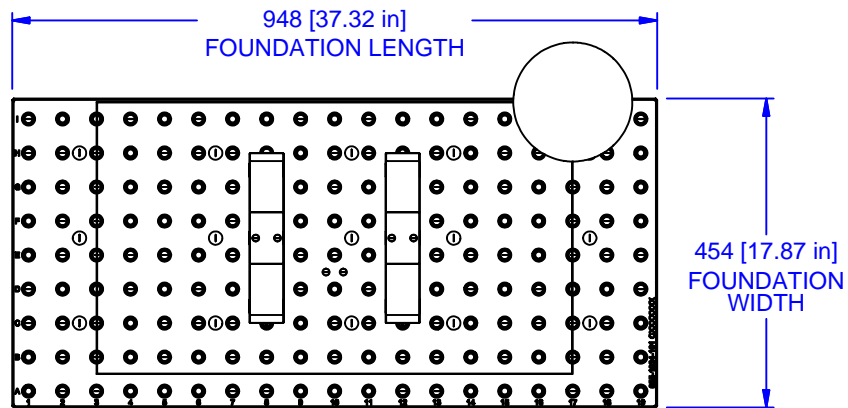

MATERIAL: NA
HARDNESS: NA
COATING: NA
WEIGHT: 134200 g
COMMENTS:

UNSPECIFIED TOLERANCES:
 X ±0.2
 X.X ±0.1
 X.XX ±0.05
 ANGLES ±0.5°
 ALL DIMENSIONS ARE MILLIMETERS.

CHICK (800) 332-4425
 (724) 772-1644
www.ChickWorkholding.com

ITEM: WORK PKG - VMC		REV A
TYPE: FANUC ROBOTDRILL T21iFL		
FAM: 081-1205 (2)		SVP-ROBO-00047
STYLE: 948 X 454 FOUNDATION		
BCE	2 OF 3	
10/30/2007		

BCE

10/30/2007

Released

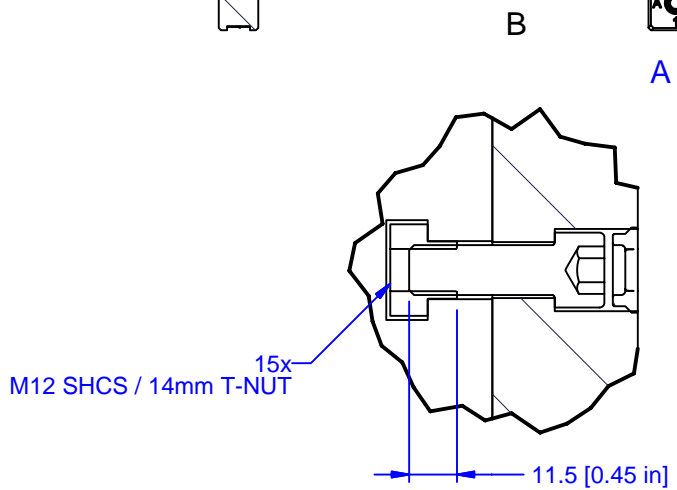
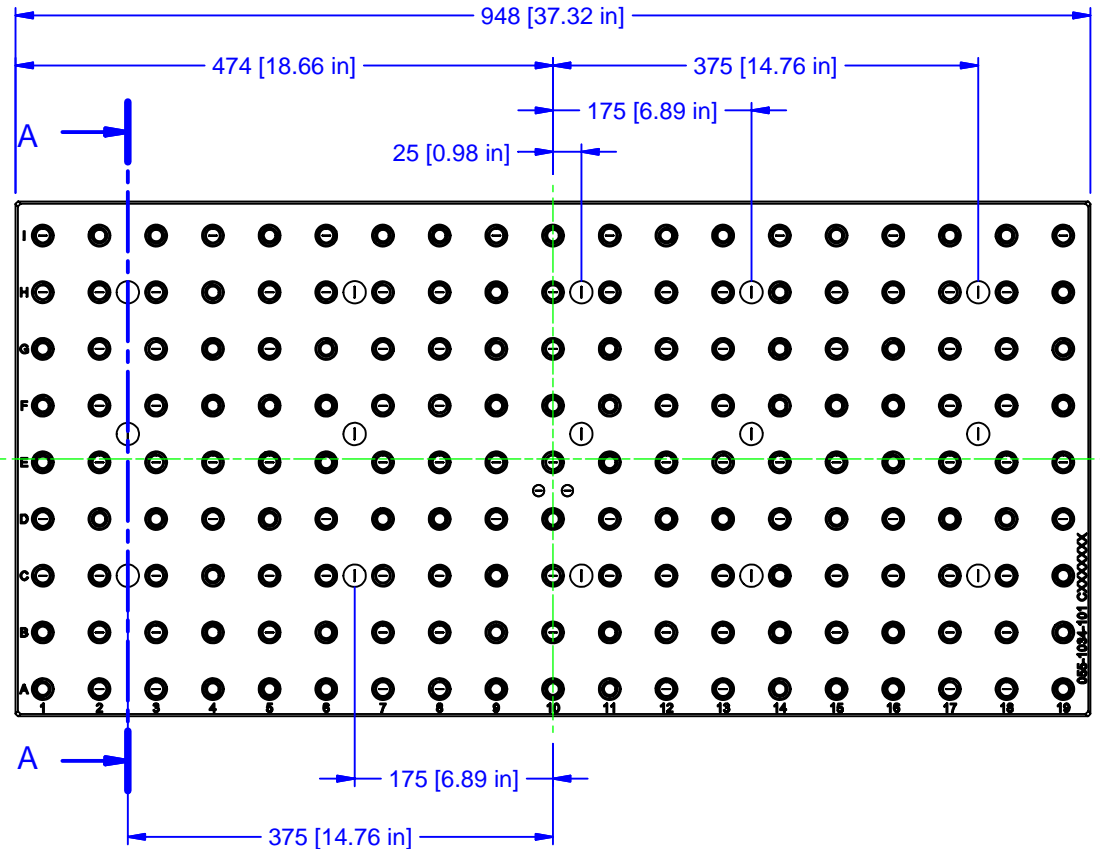
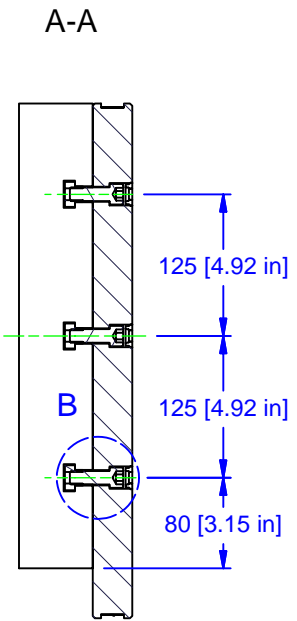

MATERIAL:	NA
HARDNESS:	NA
COATING:	NA
WEIGHT:	134200 g
COMMENTS:	

UNSPECIFIED TOLERANCES:
 X ±0.2
 X.X ±0.1
 X.XX ±0.05
 ANGLES ±0.5°
 ALL DIMENSIONS ARE MILLIMETERS.

CHICK (800) 332-4425
 (724) 772-1644
www.ChickWorkholding.com
 UNSPECIFIED EDGES: BREAK 0.3 TO 0.8
 UNSPECIFIED FILLETS: RADIUS 0.3 MAX

ITEM:	WORK PKG - VMC		
TYPE:	FANUC ROBOTDRILL T21iFL		
FAM:	081-1205 (2)		
STYLE:	948 X 454 FOUNDATION		
BCE	3 OF 3	5VP-ROBO-00047	REV A
10/30/2007			