

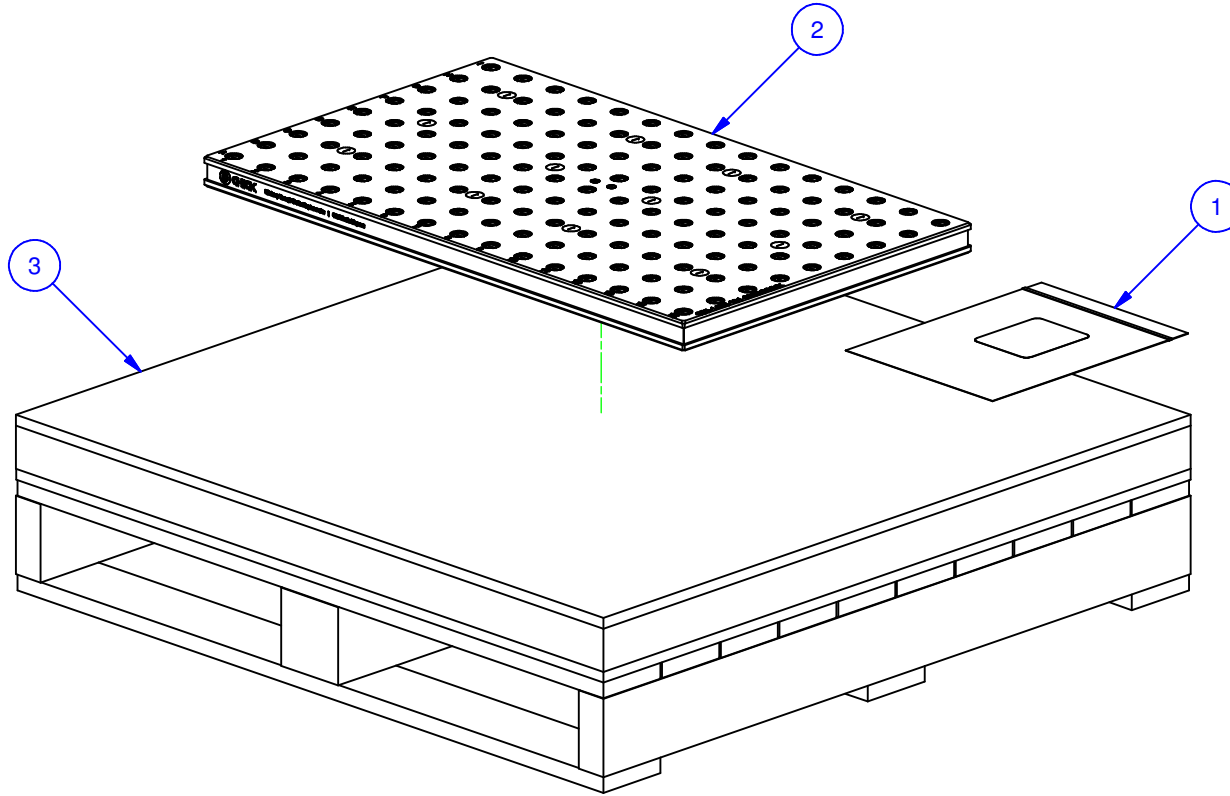

PARTS LIST						
No	QTY	PN	ITEM	TYPE	FAM	STYLE
1	1	050-2-10014	KIT	FOUNDATION MOUNTING	14mm T-SLOT	(12) M12 X 35 SHCS
2	1	055-1432-01	FOUNDATION ASSEMBLY	WP STANDARD	FANUC ROBODRILL	748 x 449
3	1	990-50-021	PACKAGING	SHIPPING CRATE	FOUNDATIONS	36" X 36"



MATERIAL: NA	UNSPECIFIED TOLERANCES: X ±0.2 X.X ±0.1 X.XX ±0.05 ANGLES ±0.5° ALL DIMENSIONS ARE MILLIMETERS.	 CHICK (800) 332-4425 (724) 772-1644 www.ChickWorkholding.com	ITEM: WORK PKG - VMC			
HARDNESS: NA			TYPE: FANUC ROBODRILL T14(21)iFe			
COATING: NA			FAM: FOUNDATION			
WEIGHT: 110347 g			STYLE: 748 X 449			
COMMENTS:		UNSPECIFIED EDGES: BREAK 0.3 TO 0.8 UNSPECIFIED FILLETS: RADIUS 0.3 MAX	TDD	1 OF 3	5VP-ROBO-00062	REV A
			9/19/2011			

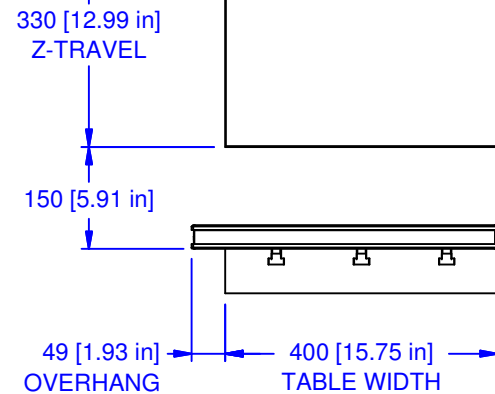
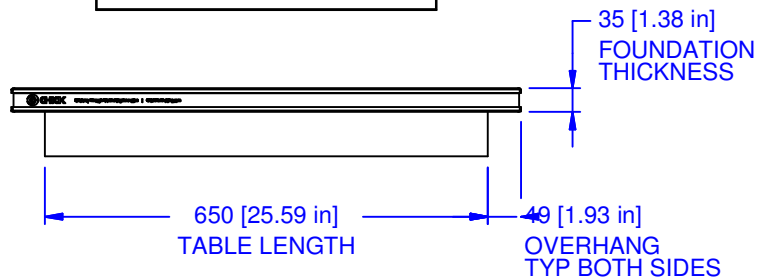
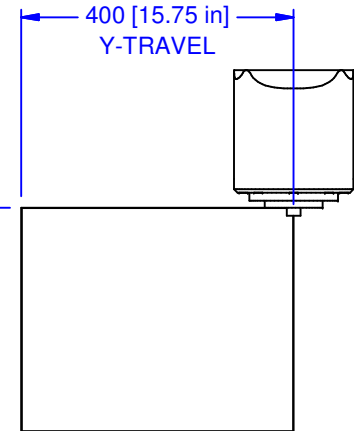
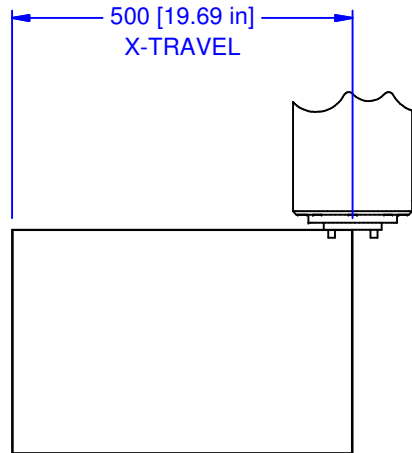
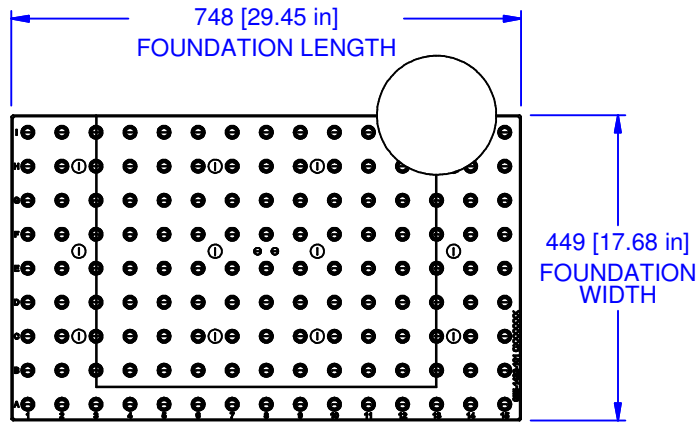

MATERIAL: NA
HARDNESS: NA
COATING: NA
WEIGHT: 110347 g
COMMENTS:

UNSPECIFIED TOLERANCES:
 X ±0.2
 X.X ±0.1
 X.XX ±0.05
 ANGLES ±0.5°
 ALL DIMENSIONS ARE MILLIMETERS.

CHICK (800) 332-4425
 (724) 772-1644
www.ChickWorkholding.com

ITEM: WORK PKG - VMC		REV
TYPE: FANUC ROBODRILL T14(21)iFe		A
FAM: FOUNDATION		
STYLE: 748 X 449		
TDD	2 OF 3	5VP-ROBO-00062
9/19/2011		

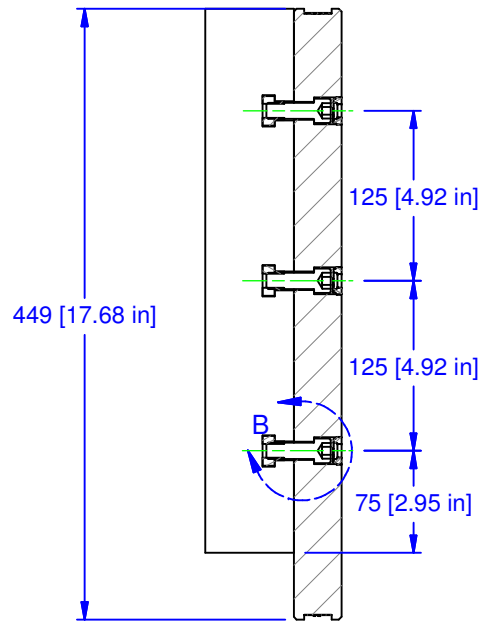

SECTION A-A

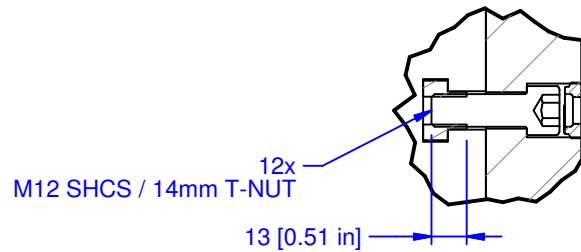

DETAIL B

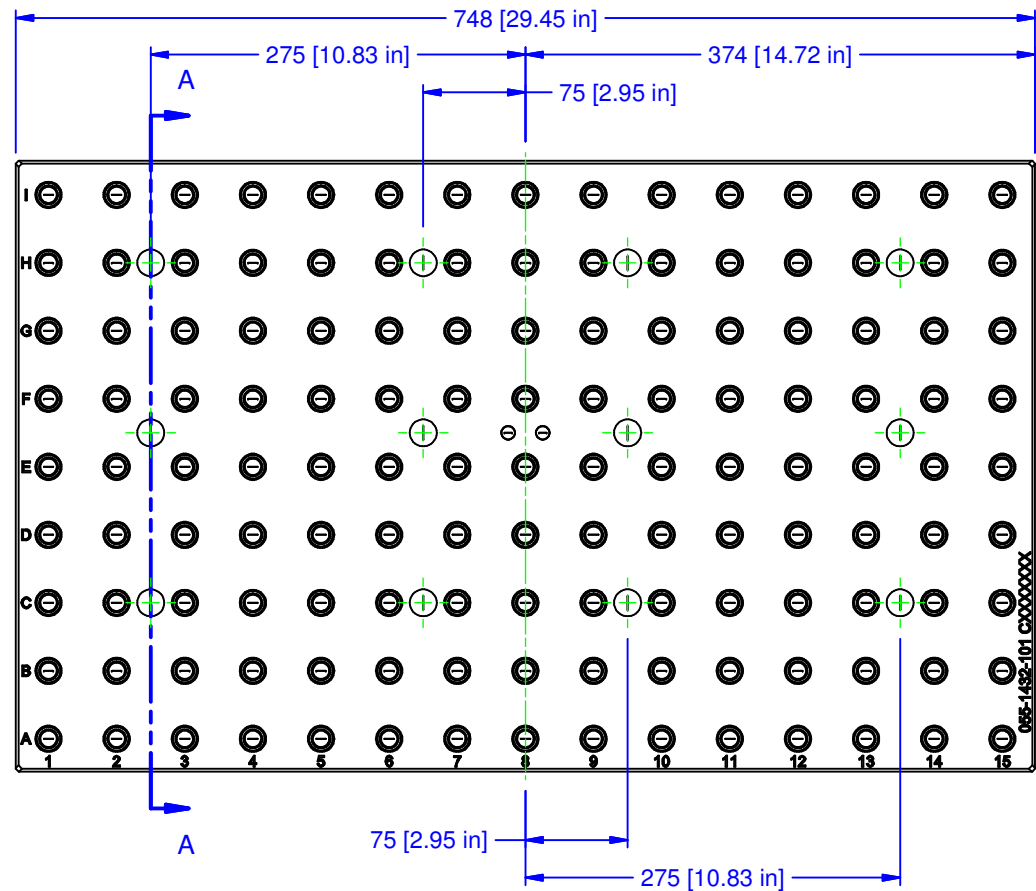

MATERIAL:	NA
HARDNESS:	NA
COATING:	NA
WEIGHT:	110347 g
COMMENTS:	

UNSPECIFIED TOLERANCES:
 X ±0.2
 X.X ±0.1
 X.XX ±0.05
 ANGLES ±0.5°
 ALL DIMENSIONS ARE MILLIMETERS.

CHICK (800) 332-4425
 (724) 772-1644
www.ChickWorkholding.com

ITEM:	WORK PKG - VMC
TYPE:	FANUC ROBODRILL T14(21)iFe
FAM:	FOUNDATION
STYLE:	748 X 449

TDD	3 OF 3	5VP-ROBO-00062	REV A
9/19/2011			