

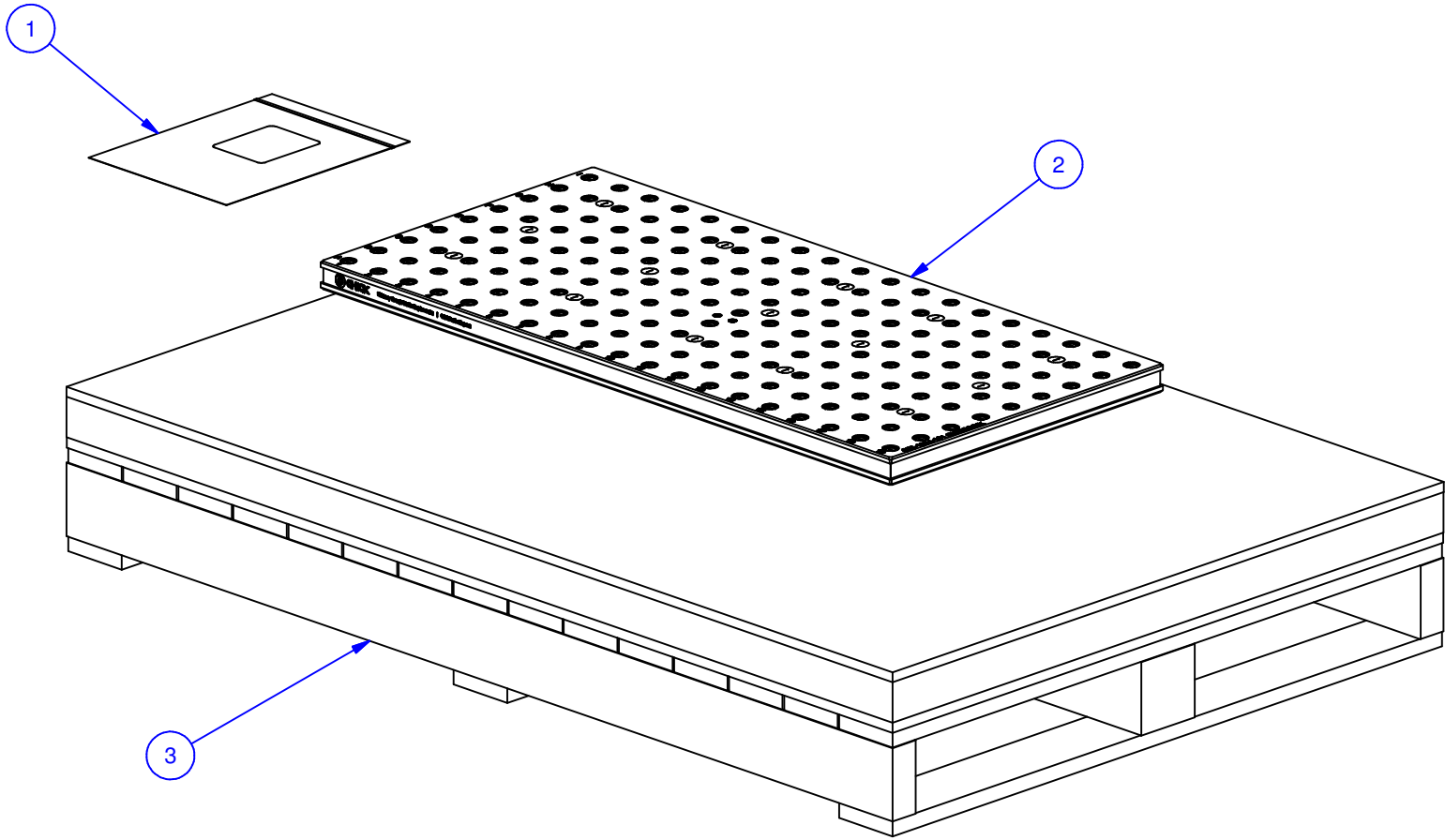

PARTS LIST						
No	QTY	PN	ITEM	TYPE	FAM	STYLE
1	1	050-2-10025	KIT	FOUNDATION MOUNTING	14mm T-SLOT	(15) M12 X 35 SHCS
2	1	055-1034-01	FOUNDATION ASSY	WP STANDARD	FANUC ROBODRILL T21-iEL	948 X 454
3	1	990-50-022	PACKAGING	SHIPPING CRATE	FOUNDATIONS	54" X 36"



MATERIAL: <b>NA</b>	UNSPECIFIED TOLERANCES: X ±0.2 X.X ±0.1 X.XX ±0.05 ANGLES ±0.5° ALL DIMENSIONS ARE MILLIMETERS.	 (800) 332-4425 (724) 772-1644 <a href="http://www.ChickWorkholding.com">www.ChickWorkholding.com</a>	ITEM: <b>WORK PKG - VMC</b>						
HARDNESS: <b>NA</b>			TYPE: <b>FANUC ROBODRILL T21-iBL</b>						
COATING: <b>NA</b>			FAM: <b>FOUNDATION</b>						
WEIGHT: <b>N/A</b>			STYLE: <b>948 X 454</b>						
COMMENTS:		UNSPECIFIED EDGES: BREAK 0.3 TO 0.8 UNSPECIFIED FILLETS: RADIUS 0.3 MAX	<table border="1"> <tr> <td>BSM</td> <td>1 OF 3</td> <td rowspan="2">5VP-ROBO-00069</td> <td rowspan="2">REV A</td> </tr> <tr> <td colspan="2">2/21/2011</td> </tr> </table>	BSM	1 OF 3	5VP-ROBO-00069	REV A	2/21/2011	
BSM	1 OF 3	5VP-ROBO-00069	REV A						
2/21/2011									

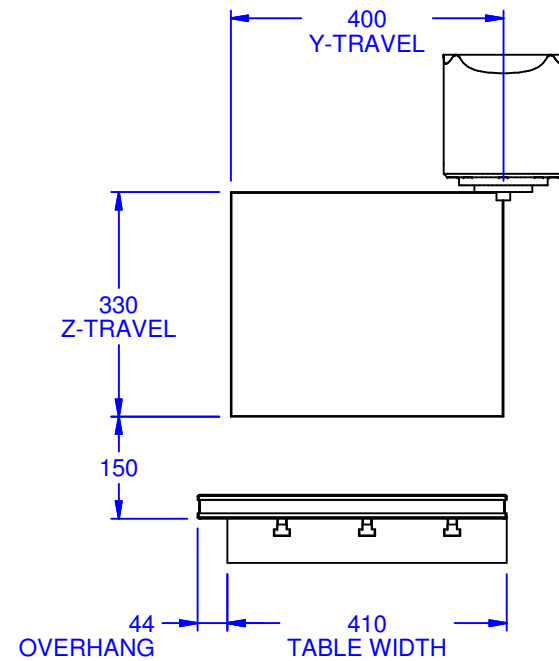
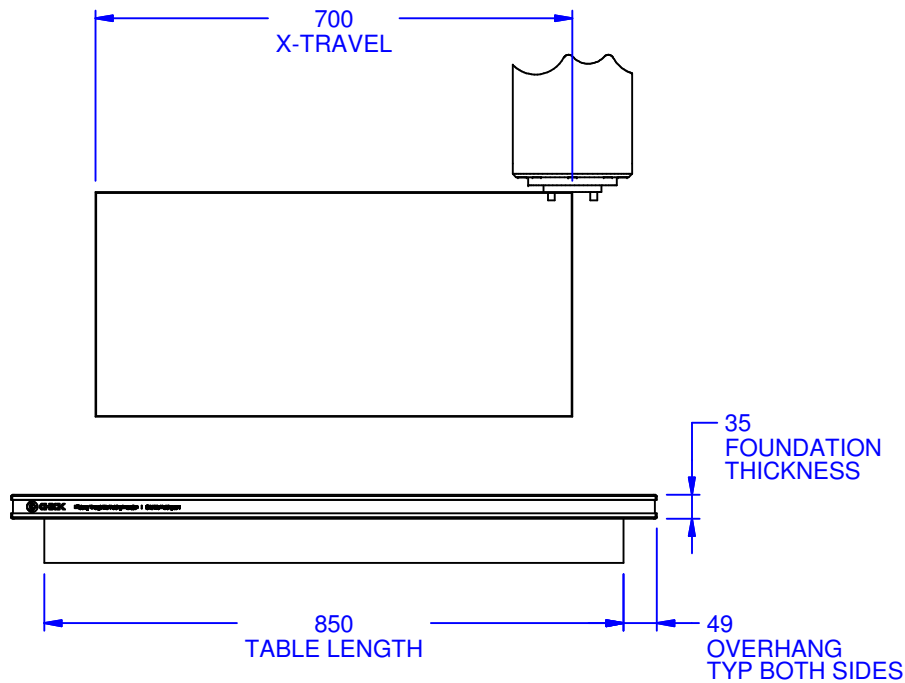
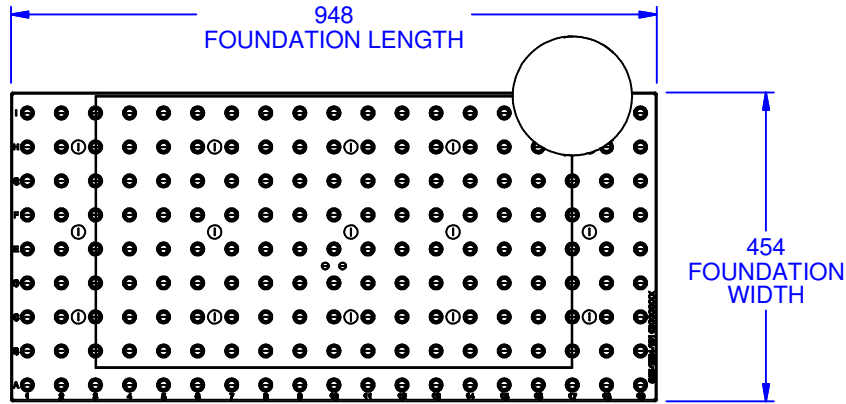

MATERIAL:	NA
HARDNESS:	NA
COATING:	NA
WEIGHT:	N/A
COMMENTS:	

UNSPECIFIED TOLERANCES:  
 X ±0.2  
 X.X ±0.1  
 X.XX ±0.05  
 ANGLES ±0.5°  
 ALL DIMENSIONS ARE MILLIMETERS.

**CHICK** (800) 332-4425  
 (724) 772-1644  
[www.ChickWorkholding.com](http://www.ChickWorkholding.com)

UNSPECIFIED EDGES: BREAK 0.3 TO 0.8  
 UNSPECIFIED FILLETS: RADIUS 0.3 MAX

ITEM: WORK PKG - VMC		REV A
TYPE: FANUC ROBO DRILL T21-iBL		
FAM: FOUNDATION		5VP-ROBO-00069
STYLE: 948 X 454		
BSM	2 OF 3	
2/21/2011		

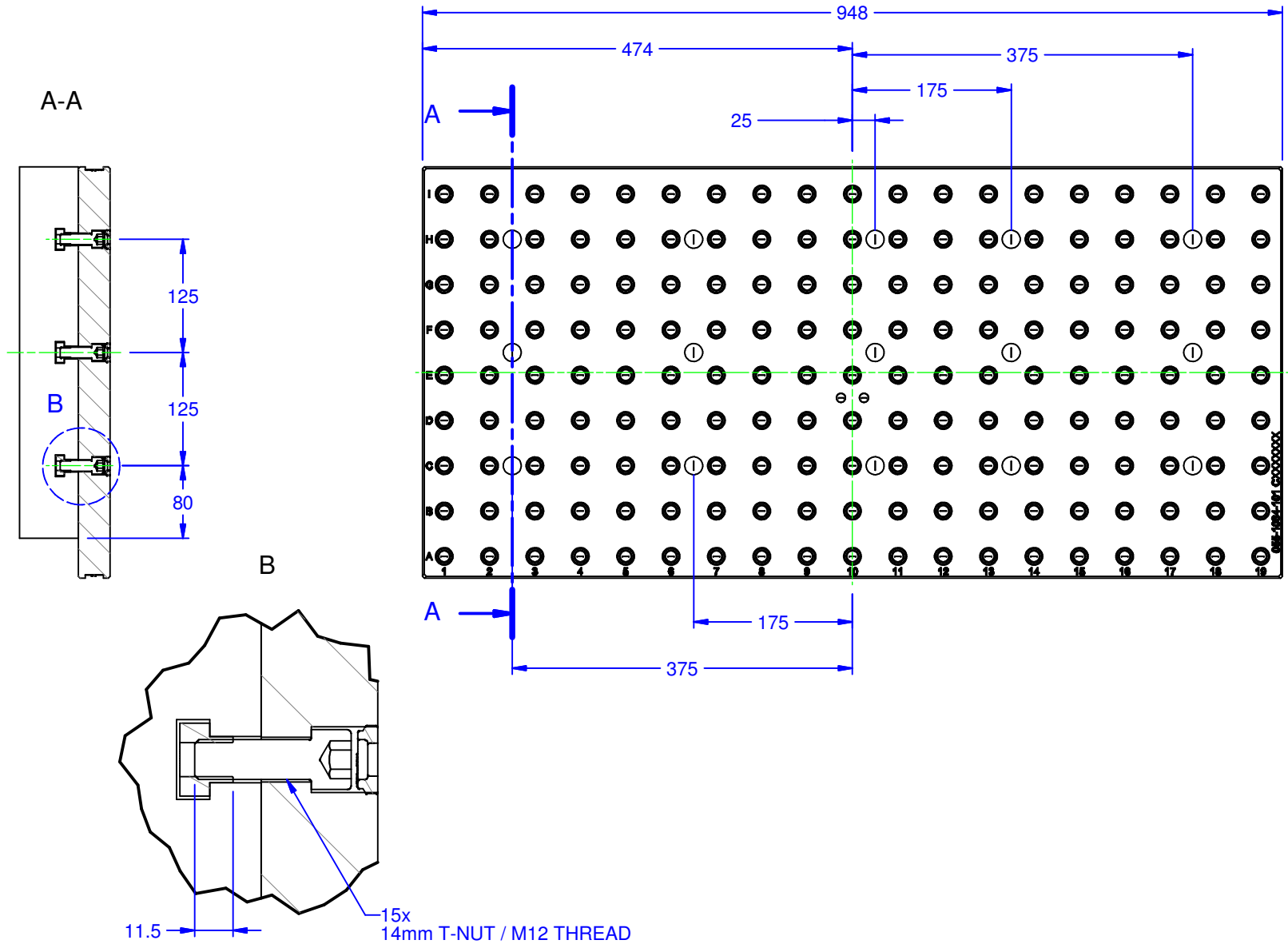

MATERIAL:	NA
HARDNESS:	NA
COATING:	NA
WEIGHT:	N/A
COMMENTS:	

UNSPECIFIED TOLERANCES:  
 X ±0.2  
 X.X ±0.1  
 X.XX ±0.05  
 ANGLES ±0.5°  
 ALL DIMENSIONS ARE MILLIMETERS.

**CHICK** (800) 332-4425  
 (724) 772-1644  
 www.ChickWorkholding.com

UNSPECIFIED EDGES: BREAK 0.3 TO 0.8  
 UNSPECIFIED FILLETS: RADIUS 0.3 MAX

ITEM: WORK PKG - VMC			
TYPE: FANUC ROBO DRILL T21-iBL			
FAM: FOUNDATION			
STYLE: 948 X 454			
BSM	3 OF 3	5VP-ROBO-00069	REV A
2/21/2011			