

One-Lok™ Single Station CNC Vise User Guide: Workpiece Clamping

STEP 1:
Insert the One-Lok swivel wrench into base.

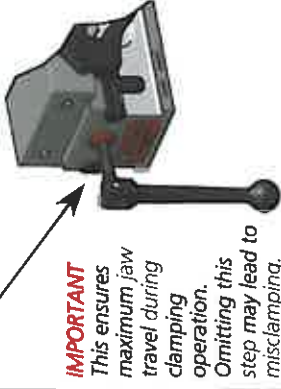

STEP 2:
Open the movable jaw to its maximum open position with the drive racks extended slightly outside the base.



STEP 3:
Depress the buttons on the quick-release toggles and rotate the toggles down to their unlocked position.



STEP 4:
Slide the movable jaw to meet your workpiece – now that's fast!



STEP 5:
Rotate the toggles back up to their locked position.

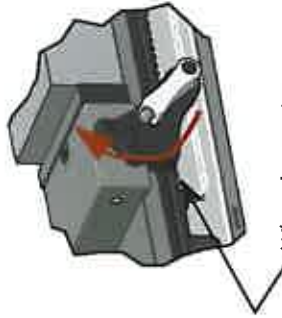

When the toggles are locked, the movable jaw will move back slightly to engage the drive racks.

STEP 6:
Clamp your workpiece down – up to 10,000 lbs! – by turning the swivel wrench only several turns clockwise.



Note: The drive racks have 20mm (.75") of travel. The pitch of the drive rack teeth is 10mm (.375).

STEP 7:
Now you can quickly unclamp and clamp successive workpieces using just the swivel wrench.

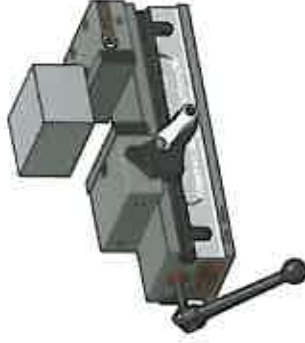

chickworkholding.com



CHICK

800.322.4425

One-Lok™ Single Station CNC Vise User Guide: Removal and Installation of BoltFast™ Jaws

STEP 1:
Insert the One-Lok T-wrench
into the locking screw.

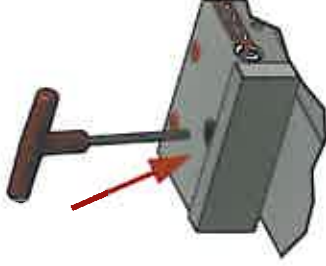

STEP 2:
Turn counterclockwise to loosen
the BoltFast locking slider.

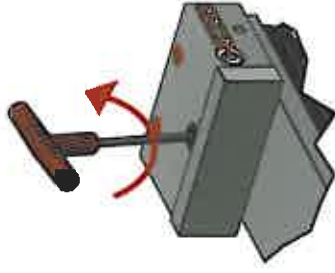

STEP 3:
Remove the BoltFast jaw by
sliding it upward.

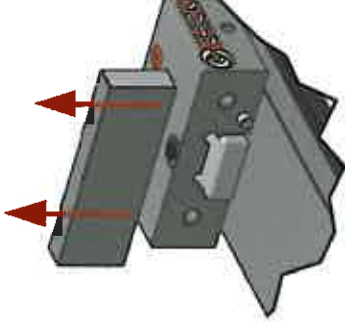

STEP 4:
Place the new BoltFast jaw by
sliding it downward onto the
locking slider.

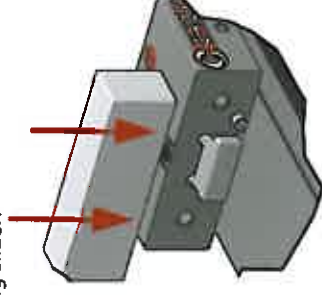

STEP 5:
Using the T-wrench, tighten
the locking screw hand-tight.

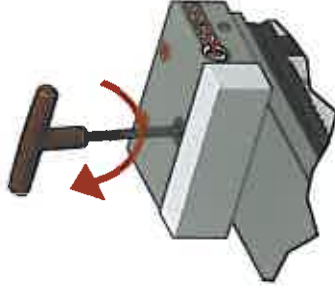

STEP 6:
Your BoltFast jaws are now
ready for clamping.



chickworkholding.com



CHICK

800.322.4425