

AUTOMATIC BAR FEEDER WITH HYDRAULIC SUSPENSION

ATTACHMENTS LIST
MANUAL FOR USE AND MAINTENANCE
KEYBOARD INSTRUCTION MANUAL
SPARE PARTS BOOK
SCHEMATICS
EC CONFORMITY DECLARATION FOR MACHINE

MASTER 880 MP E-evolution

GB

MANUAL FOR USE AND MAINTENANCE

Rel. 1 Date 01/10/02 Cod. 381005410

S/N

COMPILER: Ragazzini Gian Luca



ON APPROVAL: Bevini Claudio



MANUFACTURER: IEMCA division of IGMI S.p.A.

ADDRESS: Via Granarolo, 167 - 48018 Faenza (RA) - ITALY

Tel. 0546/698000 - Fax. 0546/46338 - 0546/46224

TLX 550879

TYPE OF DOCUMENT: MANUAL FOR USE AND MAINTENANCE

PRODUCT: AUTOMATIC BAR FEEDER WITH HYDRAULIC SUSPENSION

MODEL: MASTER 880 MP E-volution



1	GENERAL INFORMATION	MASTER 880MP E-volution
2	TECHNICAL INFORMATION	MASTER 880MP E-volution
3	SAFETY PROCEDURES - GENERAL INFORMATION	MASTER 880MP E-volution
4	HANDLING AND INSTALLATION.....	MASTER 880MP E-volution
5	ADJUSTMENTS AND SETTING-UP	MASTER 880MP E-volution
6	USE AND OPERATION	MASTER 880MP E-volution
7	BAR FEEDER MAINTENANCE	MASTER 880MP E-volution
8	TROUBLES - CAUSES - CURES.....	MASTER 880MP E-volution
9	PART REPLACEMENT	MASTER 880MP E-volution

INDEX

1.1	TERMS OF WARRANTY	2
1.2	MANUAL PURPOSE	3
1.3	MANUFACTURER AND BAR FEEDER IDENTIFICATION	4
1.4	TECHNICAL ASSISTANCE	4
1.5	ANNEXES ENCLOSED	4

 Operations described in paragraphs showing this symbol, must be performed by qualified and skilled personnel only.
Any other operation can be performed either by qualified personnel or by professional bar feeder operators.

 ***Before carrying out any servicing whatsoever on the bar feeder, it is of the utmost importance to read this manual carefully.***

1.1 TERMS OF WARRANTY

Please note that the validity of the warranty is subject to a correct alignment of the bar feeder and to the consequent floor fastening by expansion plugs (as indicated at chapter 4.4.6).

1.2 MANUAL PURPOSE

This manual has been written and supplied by the manufacturer and is integral part of the bar feeder and of its equipment.

The compliance with the instructions contained herein ensures the operator and bar feeder safety as well as a running economy and a longer life of the bar feeder itself.

In order to allow a quick search of contents, consult the descriptive index. Particularly important parts of this manual have been highlighted in bold type and preceded by the following symbols:



DANGER - WARNING:

shows impending danger which might cause serious injuries, exert the maximum caution.



CAUTION - PRECAUTION

indicates measures to be adopted to avoid accidents or damages to property.



INFORMATION

technical instructions of particular importance.

For a quick search of topics see the table of contents and/or the index.

In addition to this manual, which contains all the instructions for the bar feeder use and maintenance, two more are supplied: the "Push-button panel instruction manual" and the "Quick reference guide".

The "Push-button panel instruction manual" contains all the instructions on how to use the installed software.

The "Quick reference guide" contains the minimum required instructions to use the bar feeder and the software.

1.3 MANUFACTURER AND BAR FEEDER IDENTIFICATION

- A Manufacturer's identification
- B CE conformity marking
- C Year of manufacture
- D Bar feeder model
- E Serial number
- G Mains frequency
- H Absorption power
- M Feeding voltage
- N Direct driving voltage
- P Air pressure
- Q Bar feeder and pusher length
- R Breaking capacity
- S Number of base wiring diagram
- T Number of interface wiring diagram

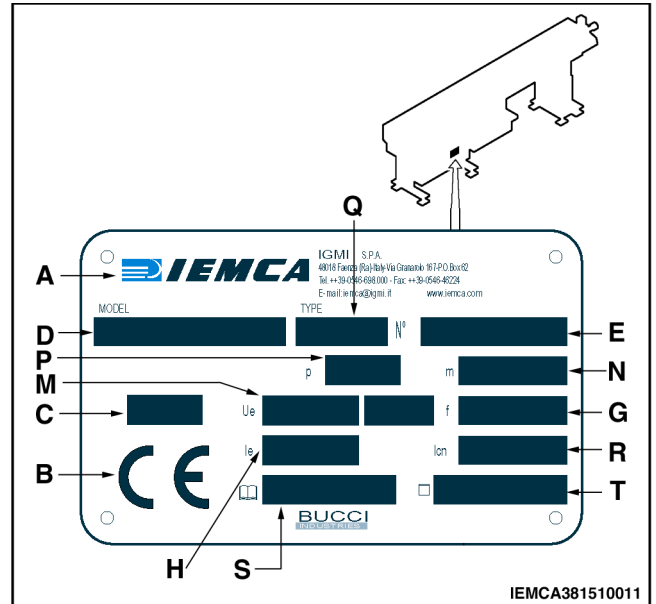
**INFORMATION:**

Always provide the Manufacturer with the above mentioned specifications when requesting information or ordering spare parts, etc.

1.4 TECHNICAL ASSISTANCE

Whenever necessary, please apply to one of the Technical Assistance Centres shown in the attached list.

**INFORMATION**

when requesting technical assistance for the bar feeder, always specify the information shown on the machine dataplate.

1.5 ANNEXES ENCLOSED

- Push-button panel instruction manual.
- GUIDES - BAR PUSHER - REVOLVING TIPS - COLLETS. Manual for choice.
- Wiring diagram.
- Pneumatic diagram.

INDEX

2.1	GENERAL DESCRIPTION OF THE BAR FEEDER	2
2.1.1	Bar feeder - Main components.....	3
2.1.2	Hydraulic system - Main components	4
2.1.3	Pneumatic system - Main components	5
2.2	OPERATING CYCLE	6
2.3	Bar feeder - Safety devices	10
2.4	SAFETY PLATES - POSITION AND DESCRIPTION.....	11
2.5	DESCRIPTION OF THE VERSIONS	12
2.6	TECHNICAL DATA	13
2.6.1	Noise levels	18
2.7	FITTINGS - FOREWORD	19
2.7.1	Bush-holder device - Description	19

2.1 GENERAL DESCRIPTION OF THE BAR FEEDER

The MASTER 880 automatic bar feeder is used in the machine-tool industry and in particular, for automatic lathe feeding.

The working cycle is controlled by a control panel with built-in PLC, which is able to dialogue with the lathe control.

The digital hand-held keyboard makes programming easier and allows the bar-feeder functions to be controlled without leaving the lathe.

The bar feeder can be used to feed bars, pipes and various sections.

The guide channel is fully closed during machining; a pump is provided to maintain a continuous oil flow inside the channel, creating a hydrodynamic support effect; these characteristics allow the bar to rotate at a high r.p.m. number, with no vibrations and no surface damaging.

Thanks to the use of a "BRUSHLESS" and electronically controlled motor, the bar speed, thrust value and feeding position may be determined at any time during the working cycle.

Bar remnant ejection can be caused by bar-pusher feeding or next bar feeding.

The lathe tooling and maintenance can be easily carried out due to the axial displacement of the bar feeder body.

2.1.1 Bar feeder - Main components

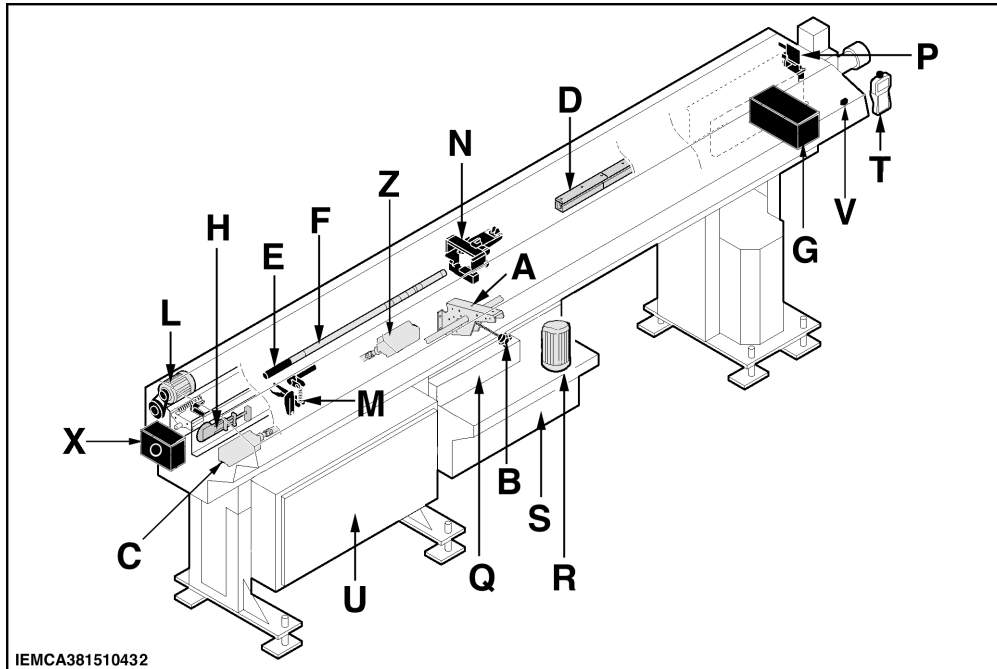

- A Magazine; where bars are stored.
- B Bar selectors; this selects the first bar contained in the magazine, so that it can be afterwards loaded by the lifting device.
- C Bar lifting device; this lifts the first bar contained in the magazine.
- D Guide channels; they drive the bar during the machining.
- E First feeding carriage; it pushes the bar forward until the necessary space for the bar pusher connection has been created.
- F Bar pusher; it pushes the bar during the machining. The collet is fixed on its front end.
- G Bar pusher drive; it drives the bar pusher.
- H Feed chain; it transmits the motion from the drive to the bar pusher.
- L Cam drive; it drives the opening and closing of the clamps, the opening and closing of the guide channels, the lifting and lowering of the bar drop device.
- M Pneumatic bar drop control devices; they control the bar during the drop into the guide channels.
- N Clamps; they hold the bar during its loading and removal from the bar pusher collet.
- P Facing device; it sends a signal during the bar passage.
- Q Remnant collection box; it collects the bar remnant.
- R Lubricating pump; it delivers oil to the guides.
- S Oil tank; contains the lubricating oil.
- T Hand-held keyboard; it allows bar feeder programming and function actuation.
- U Electric cabinet; houses the electric switchboard.
- V Axial displacement; it helps to remove the bar feeder body from the lathe.
- Z Pneumatic bar drop controls cylinder
- X Pneumatic clamps cylinder

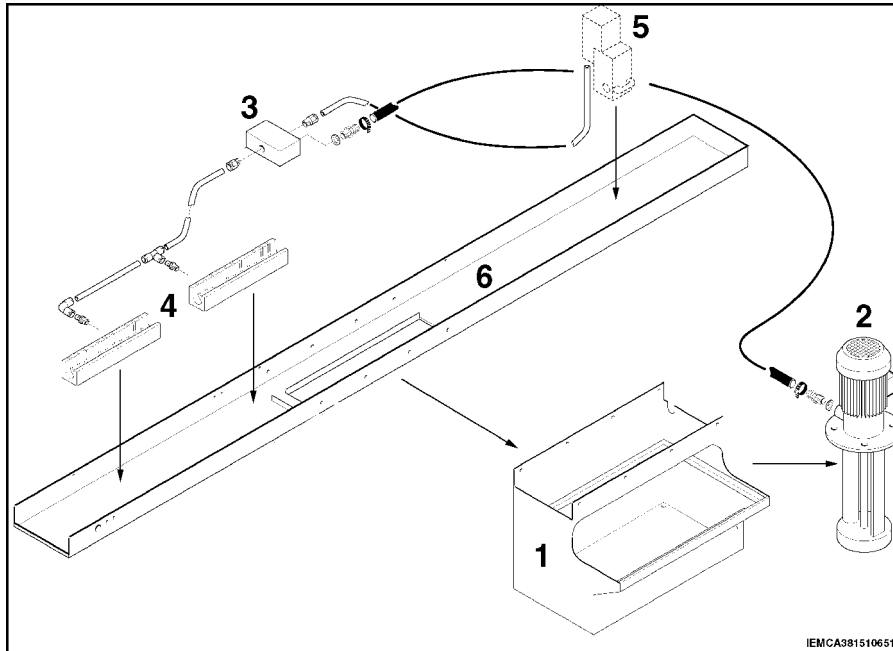
2.1.2 Hydraulic system - Main components

- 1 TANK
- 2 PUMP
- 3 DIRECTIONAL CONTROL VALVE
- 4 GUIDES
- 5 BUSHING
- 6 OIL RECOVERY TRAY

Lubrication oil cycle: forced by pump (2) installed in tank (1), the oil flows to guides (4) and bushing holder (5) to lubricate the bars in production.

From these two devices the oil enters recovery tray (6) from where it is returned to the tank via a filter for use in the next lubrication cycle.

2.1.3 Pneumatic system - Main components

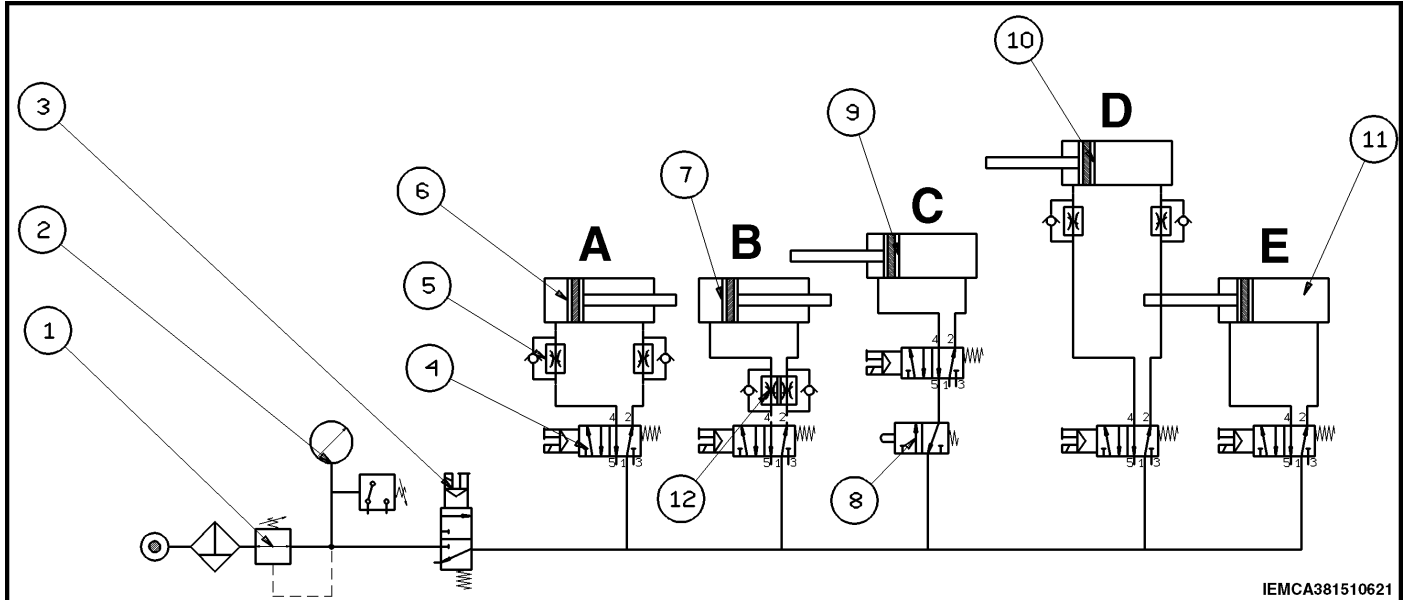

IEMCA381510621

- A - PNEUMATIC BAR DROP CONTROL DEVICE UNIT
- B - FACING UNIT
- C - BUSHING DRIVE UNIT
- D - BAR SELECTORS UNIT
- E - PNEUMATIC CLAMPS CYLINDER

POS.	DENOMINATION
1	FILTER
2	PRESSURE GAUGE
3	VALVE
4	ELETCTROVALVE
5	CONNECTION
6	CYLINDER
7	CYLINDER
8	VALVE
9	CYLINDER
10	CYLINDER
11	CYLINDER
12	VALVE

2.2 OPERATING CYCLE

The automatic functioning controls the motions of the bar feeder according to the sequence described below.

The bar pusher (A) makes bar (B) move forward in the lathe until the bar runout.

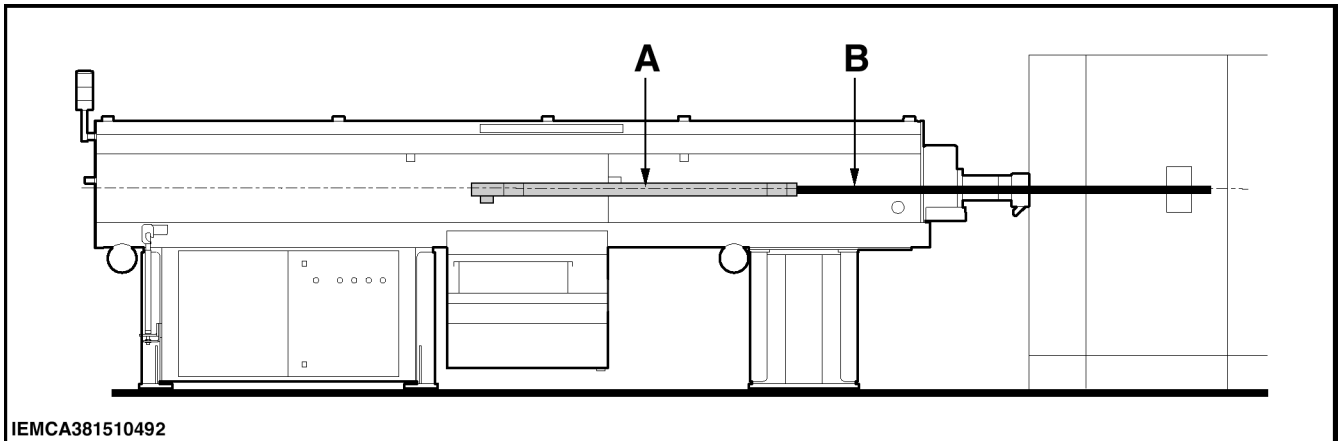

The bar-pusher (A) and remnant (C) are in their forwards limit stop position.

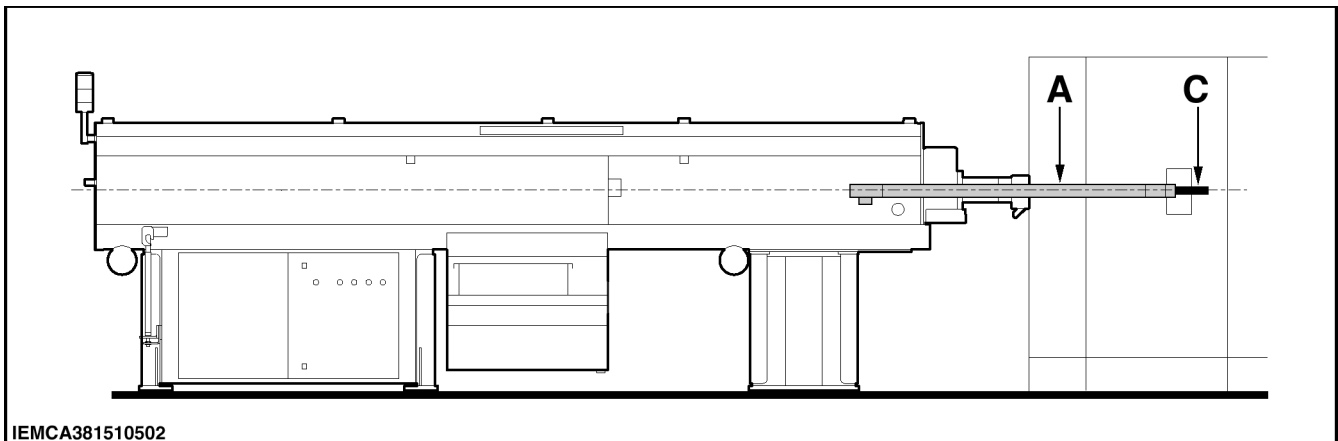

The bar-pusher (A) and remnant (C) reach their backwards limit stop position. The clamps (D) close and the bar pusher moves backwards; the remnant is removed from the collet. The clamps open and the bar remnant drops into collection box (E).

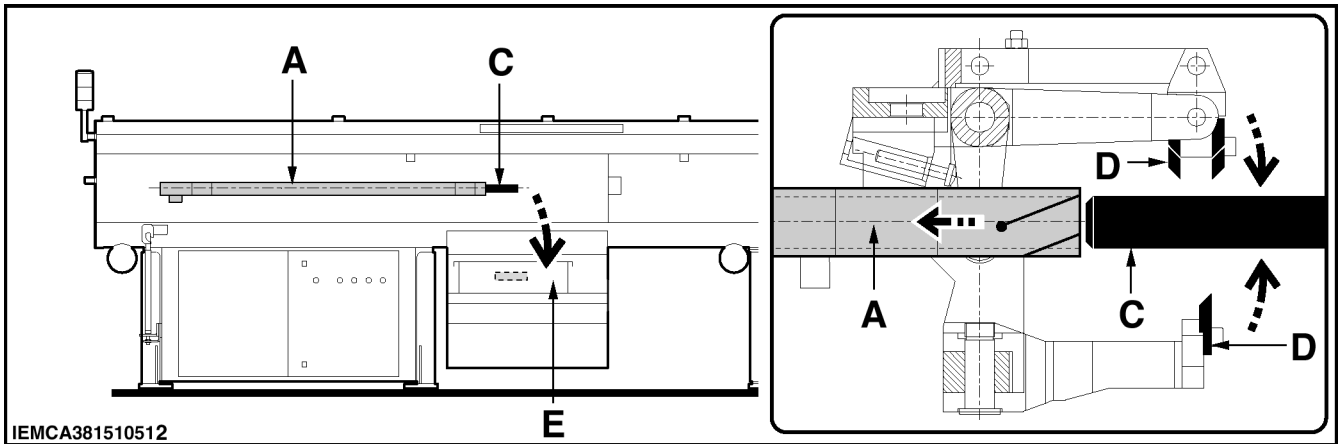

When dropping, bar remnant (C) activates a control device. If the bar remnant is still inside the collet of the bar pusher, the bar feeder stops, otherwise the cycle goes on.

The top guides (G) are lifted together with the bar pusher (H), and also the bar control devices are lifted.

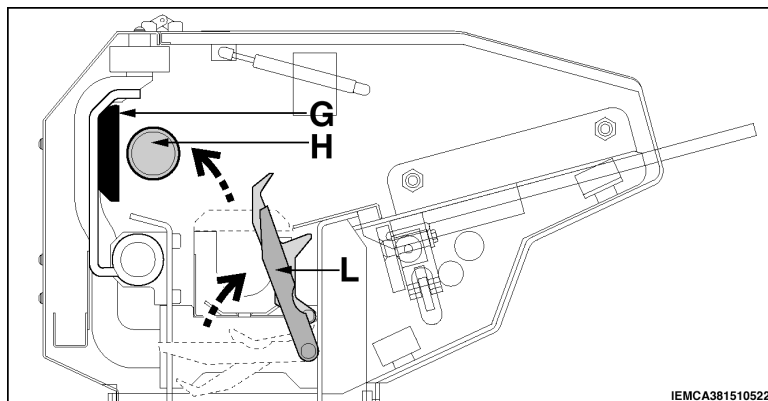

Bar lifts (L) load bar (M) that falls into lower guides (N) with the help of levers (H).

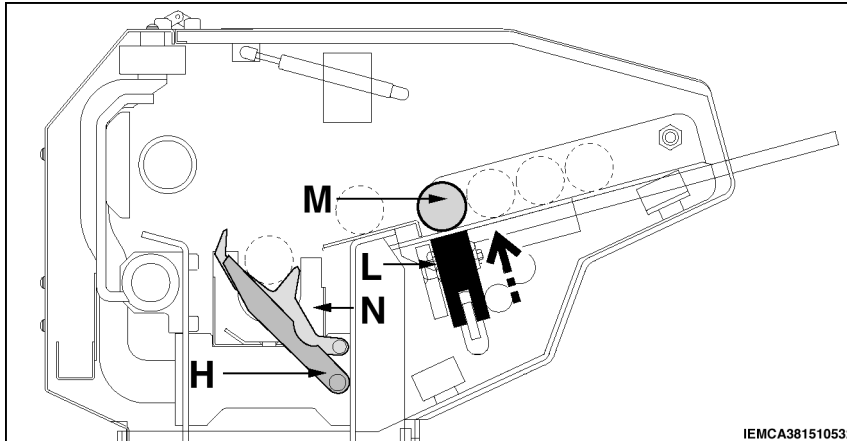

The 1st feeding carriage (P) stroke begins.

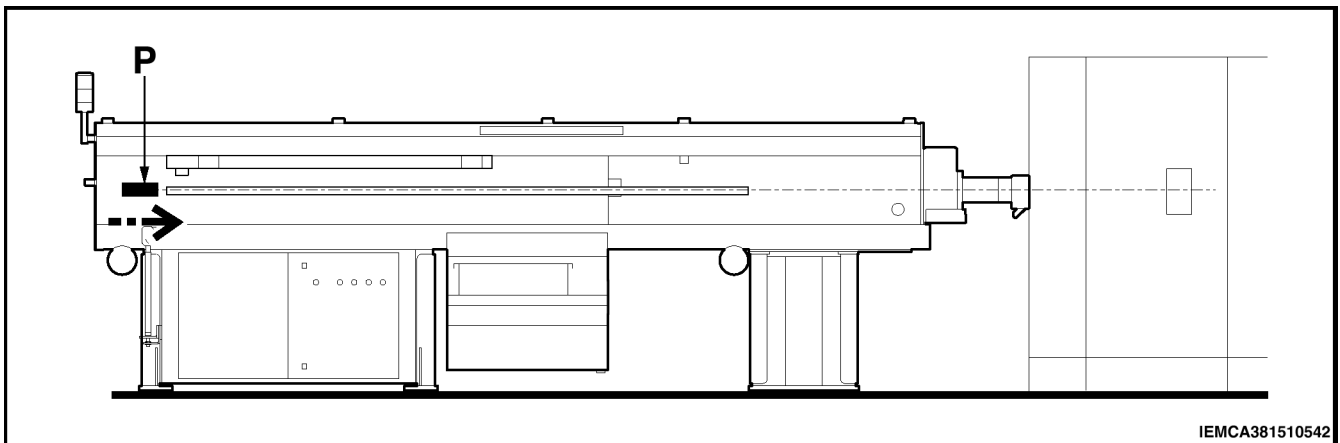

When the small pusher truck (P) completes its stroke, the required space has been created for bar-pusher insertion.

The small pusher truck executes its return stroke.

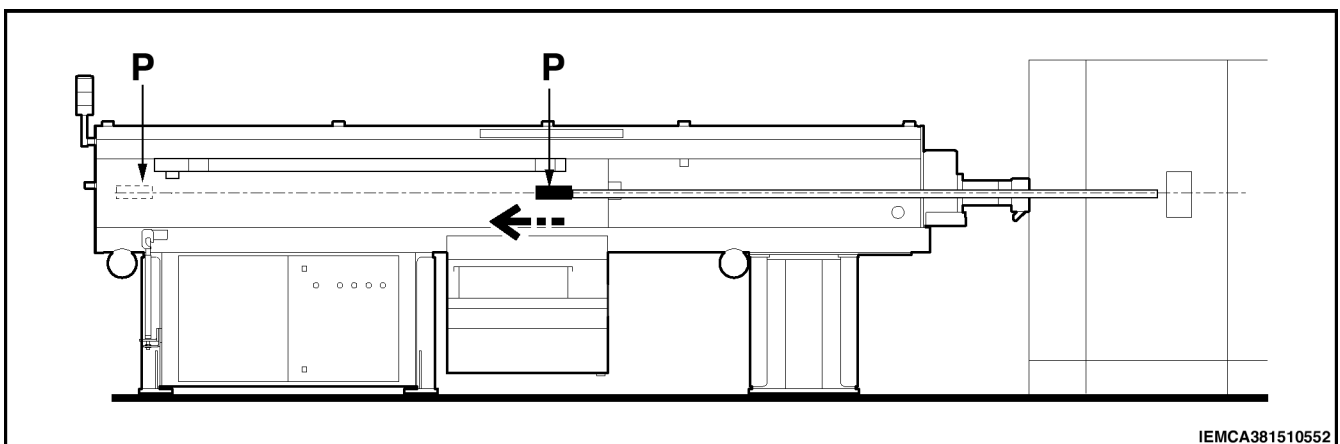

The upper guides (G) are closed; the bar-pusher (H) is positioned along the spindle axis.

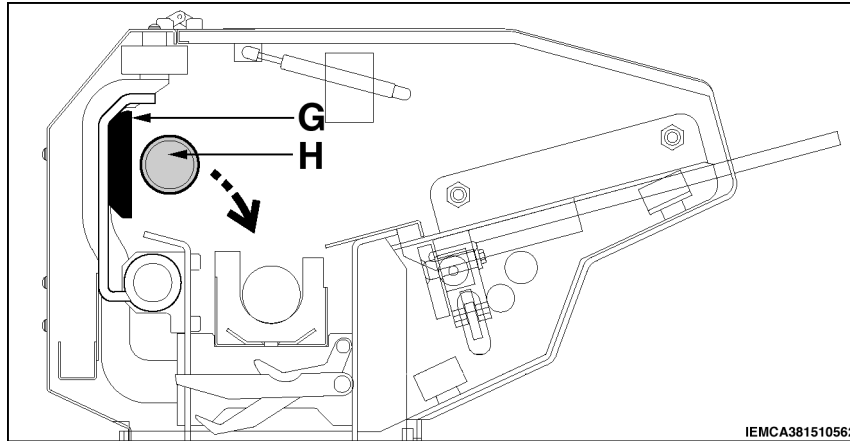

The clamps (D) close, the bar-pusher (A) moves forwards; the bar (N) is inserted into the bar-pusher collet.

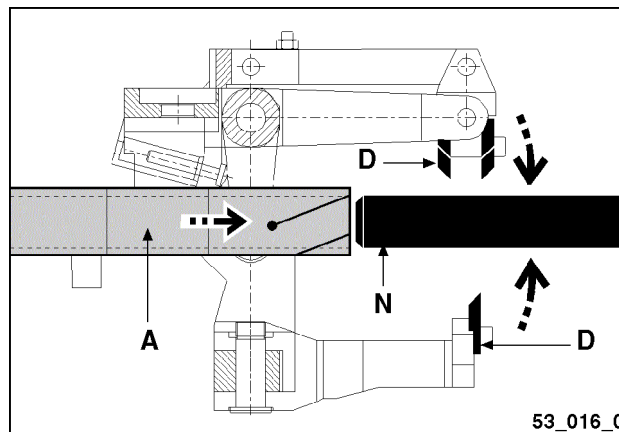

The bar-pusher (A) and bar (N) execute their facing stroke. A new automatic work cycle is started.

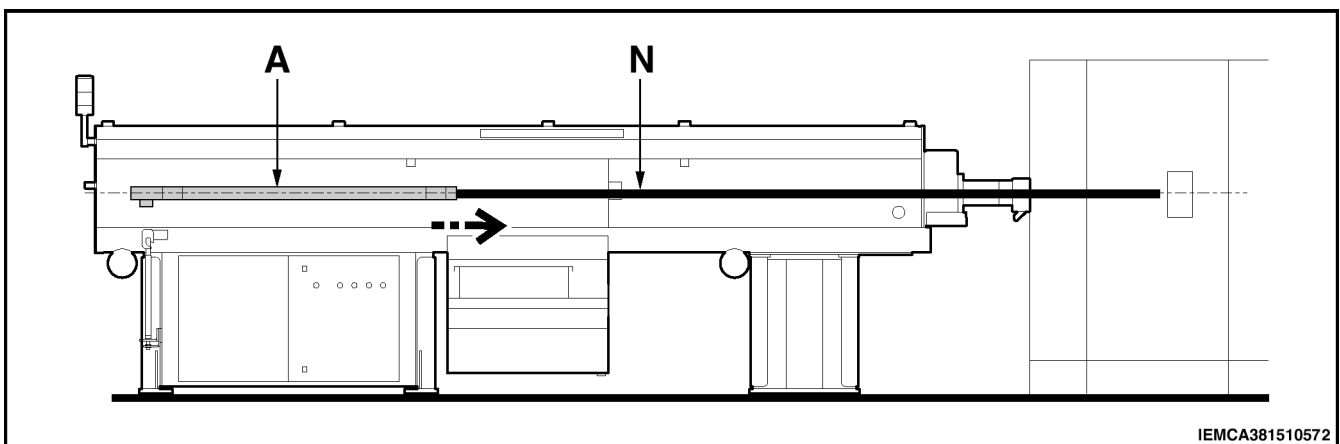

2.3 Bar feeder - Safety devices

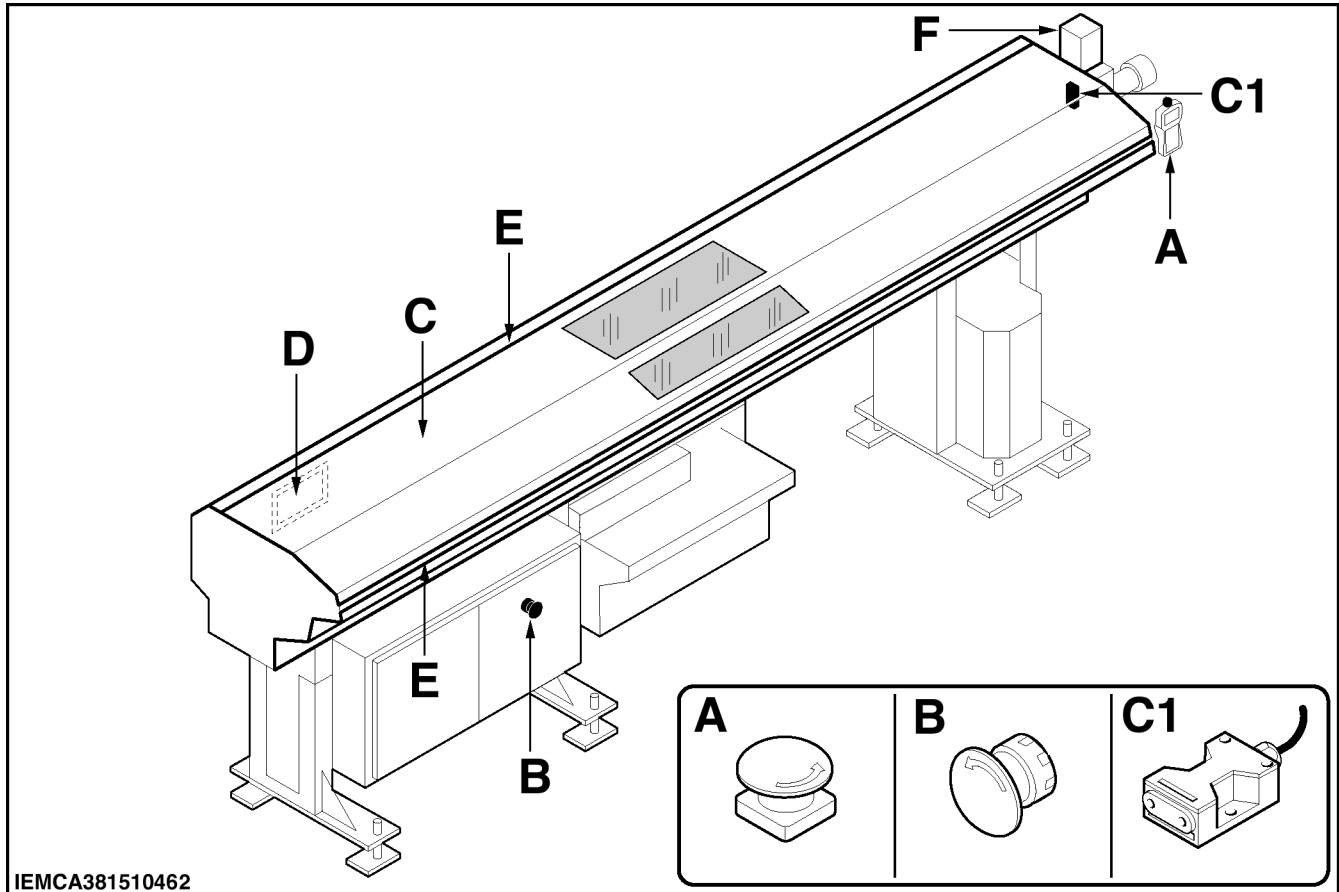

- A-B Emergency push-button; when pressed, all the bar feeder and lathe functions stop in emergency condition.
- C Interlocked mobile guard: associated with microswitch C1. According to the cycle setting, its functions are:
 manual cycle;
 -on guard opening, the bar feeder controls are locked with the exception of bar pusher movement controls.
 automatic cycle;
 -during the bar feeding phase, the guard opens to allow magazine refilling. Although the bar feeder and lathe functions are not stopped, there are no residual risks for the operator within the area.
 -during the bar change phase, on guard opening, the bar feeder and lathe functions are stopped. Guard closure allows the cycle to be restarted by the operator.
- D Fixed guard: it is made from transparent material to allow visual inspection of the bar feeder devices.
- E Fixed guard: hinders an accidental access to the operating components.
- F Fixed guard: it prevents accidental access to the bar selection area.

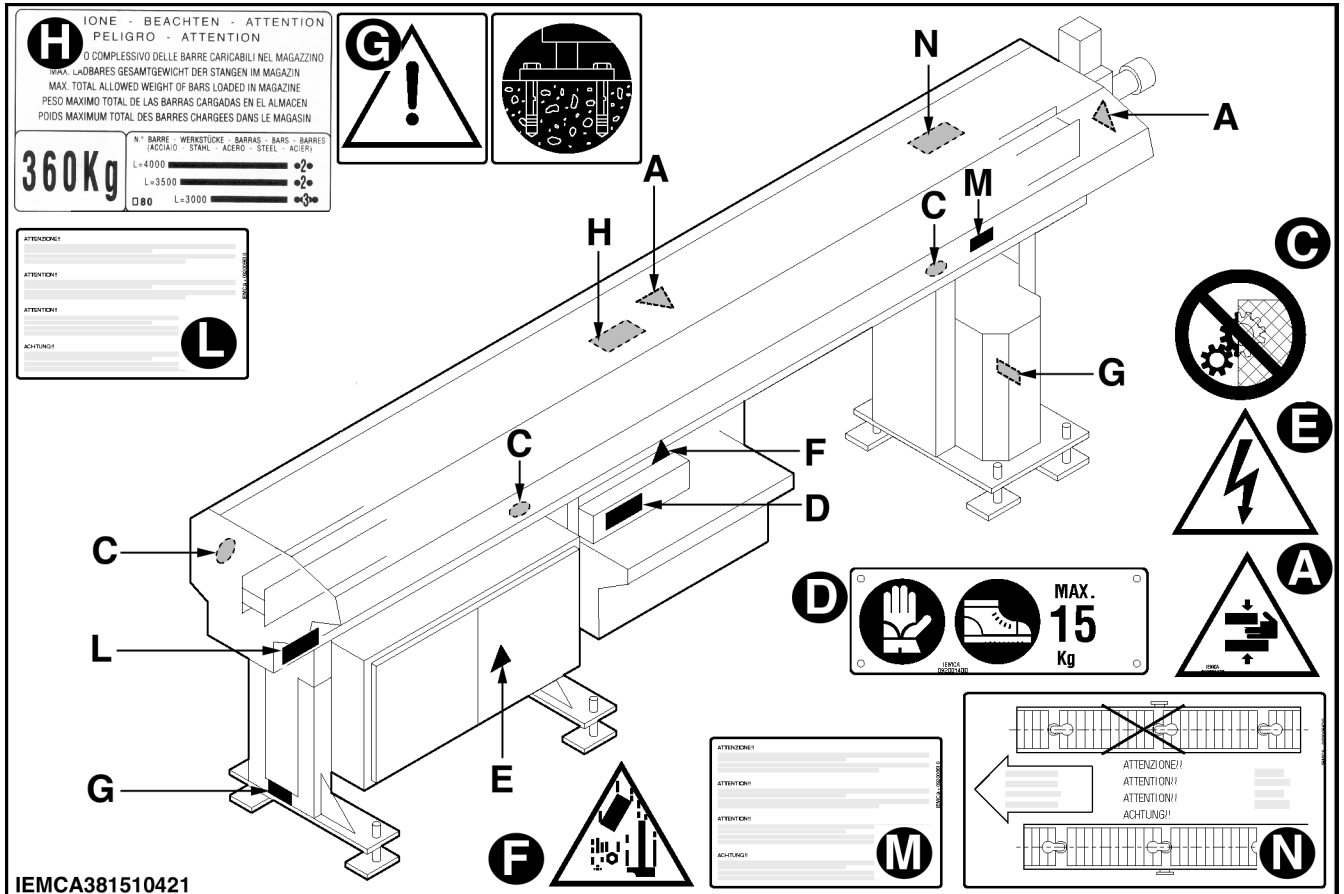
2.4 SAFETY PLATES - POSITION AND DESCRIPTION

- A Danger of upper limb crushing.
- C Do not remove the safety barriers.
- D Wear safety gloves and shoes.
Do not lift loads exceeding 15 kg manually.
- E Caution! Danger of electric contact.
- F Warning; danger of falling material.
- G Warning: fix the bar feeder to the ground.
- H Maximum overall weight of magazine loadable bars.
- L Warning; axial sliding
- M Warning; oil leakage.
- N Warning; respect the correct guide channel assembly direction.

2.5 DESCRIPTION OF THE VERSIONS

Table 1. Bar length

Modello	Versione	Lunghezza massima mm (ft)	Lunghezza minima mm (ft)
MASTER 880 MP Evolution	33	3300 (10,8)	1000 (3,2)
	38	3800 (12,4)	
	43	4300 (14,1)	

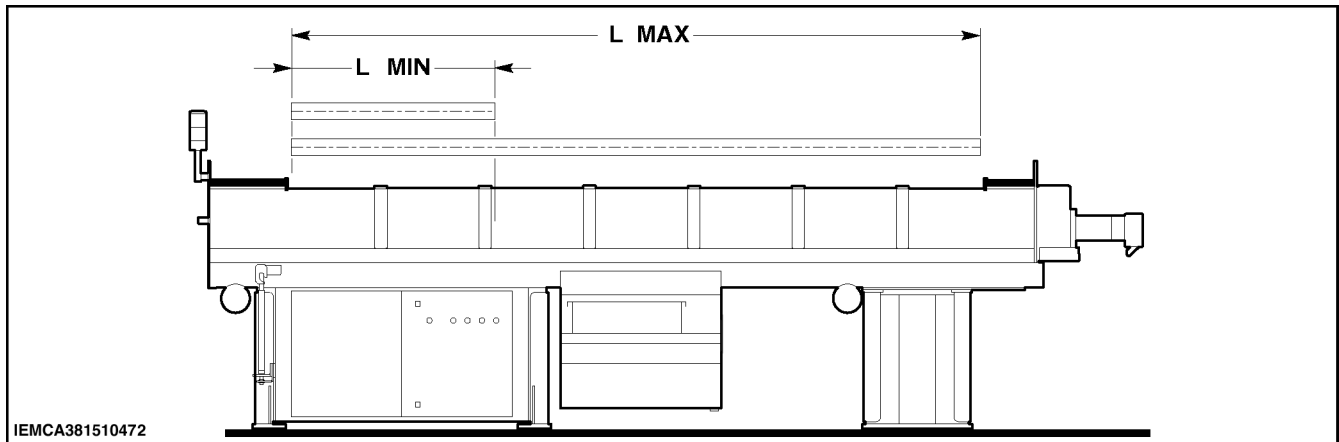
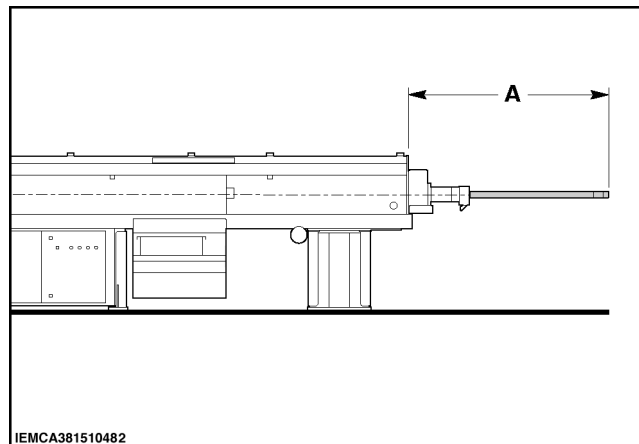

Table 2. Bar pusher max. extension

Model	Version	Version	A - Max. extension (mm)
MASTER 880 MP Evolution	33-38-43	L	1350
		LL	1600
	38-43	XLL	1850



2.6 TECHNICAL DATA

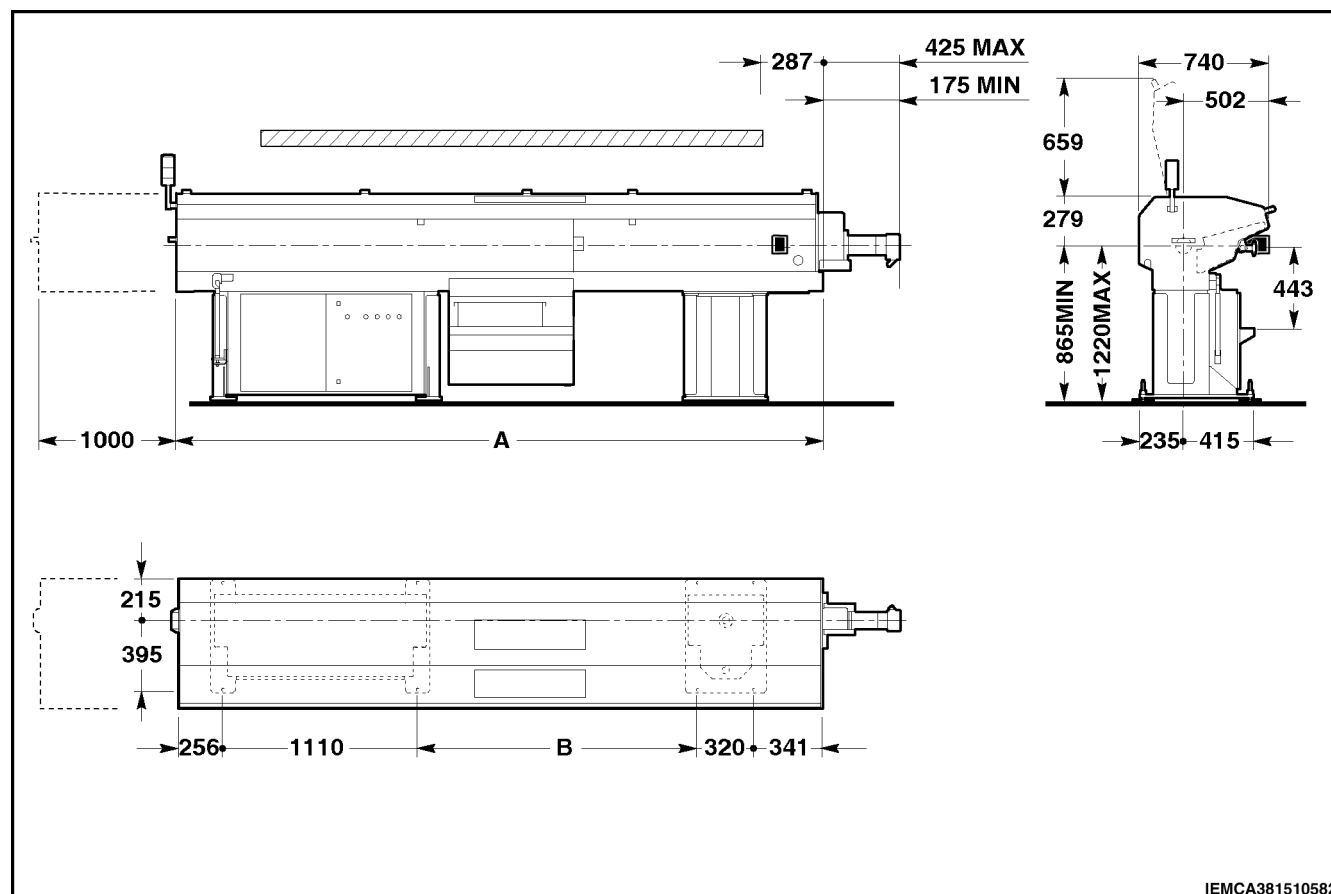

Table 3. Overall dimensions

Model	Version	A (mm)	B (mm)
MASTER 880 MP Evolution	33	4000	1950
	38	4500	2450
	43	5000	2950

Table 4. General technical specifications

	MASTER 880 MP Evolution	
Round bar diameter	Ø min 8 mm (5/16")	Ø max 80 mm (3")
Hex bar diameter	min 10 mm (5/16")	max 50 mm (2"1/4)
Max bar length	min 7 mm (5/16")	max 65 mm (2")
Min bar length	1000 mm	
Max bar length	Mod. 33 – 3300 mm (10,8 ft) Mod. 38 – 3800 mm (12,4 ft) Mod. 43 – 4300 mm (14,1 ft)	
Magazine capacity (maximum allowable load)	~360 kg	
Magazine capacity (Working width)	270÷320 mm (es. n° 34 bars with a diameter Ø 8 mm, n° 4 bars with a diameter Ø 80 mm)	
Remnant max. length	Ø 8÷65 = 400 mm Ø 66÷80 = 250 mm	
Bar change-over time (with 3000 mm bar)	30 sec (varying according to the bar diameter)	
(Adjustable) feeding speed	150 mm/sec	
(Adjustable) return speed	950 mm/sec	
Input voltage	230/400 Volt	
Control voltage	24 Volt A.C. – 24 Volt D.C.	
Installed power	3 kW	
Air pressure	6 bar	
Oil quantity	80 l	
Air consumption	6 NI/min	
Bar feeder weight	Mod. 33 – 1360 kg. Mod. 38 – 1440 kg. Mod. 43 – 1520 kg.	

Table 5. Working axis height

Model	Upper screws position	X (mm)
MASTER 880 MP Evolution	1	865÷899
	2	900÷939
	3	940÷969
	4	975÷1009
	5	1010÷1044
	6	1045÷1079
	7	1080÷1114
	8	1115÷1149
	9	1145÷1179
	10	1180÷1220

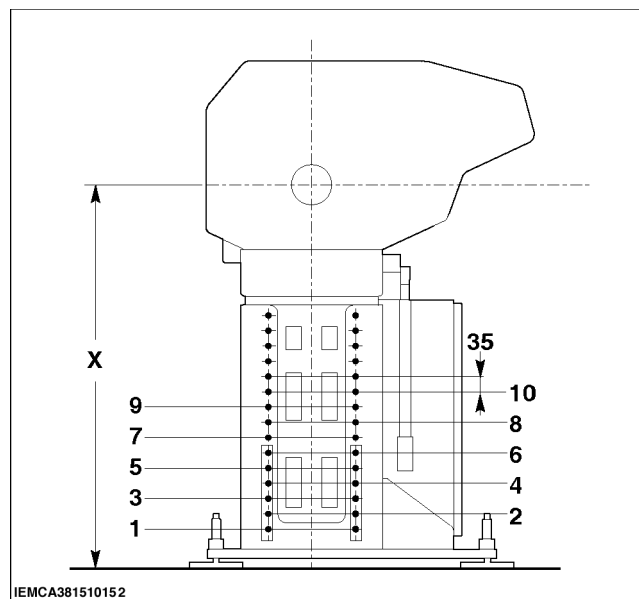

Table 6. Guide channel, bar pusher, bar and tube diameters

Model	Guide channel diameter (mm)	Bar pusher diameter (mm)	Bar diameter		Tube diameter (mm) (*)
			Minimum	Maximum	
MASTER 880 MP Evolution	21	20	8	18	20
	26	25	8	23	25
	33 (**)	32	10	29	31
	36	35	10	32	35
	43	42	12	39	42
	46	45	15	42	45
	52	51	18	47	51
	57	56	22	52	56
	61 (**)	60	30	56	60
	66	65	38	61	65
	69	68	48	63	68
	71	70	48	65	70
	73	72	50	67	72
	76	75	50	70	75
	81	80	52	75	80
	86 (**)	85	55	80	80

(*) Valid also for prepared bars or normal bars machined with front remnant ejection.

(**) Recommended guide according to max lathe bar passage.

Example: ø85 max bar passage - GUIDES 86-61-33.

Example: ø80 max bar passage - GUIDES 81-61-33.

Example: ø75 max bar passage - GUIDES 76-61-33.

Table 7. Guides lubricating oils

Model ISO and UNI	Make	Name
CLASSE C CKB 150	Agip	Acer 150
	Api	Api Cis 150
	BP	Energol CS 150
	Castrol	Magna 150
	Chevron	Circulating Oil 150
	Elf	Movixa 150
	Esso	Nuto 150
	Fina	Solna 150
	IP	IP Hermea 150
	Klüber	Crucolan 150
	Mobil	Vectra Oil Heavy
	Olio FIAT	Daphne LPN 150
	Roloil	Arm V 150
	Shell	Vitrea 150 Tellus C 150
	Tamoil	Industrial Oil 150
	Texaco	Omnis 150
	Total	Cortis 150 Azolla ZS 150
Aral	Aral Degol Tu 150	

Table 8. Air lubricator oils

Designazione ISO/UNI	Make	Name
ISO e UNI VG 10	BP	Energol HP 10
	SHELL	Tellus C 10
	MOBIL	DTE 21
	ESSO	Spinesso 10

Oil quantity: 80 litres

2.6.1 Noise levels

Bar feeder does not cause acoustic noise.

Noise occurs when lathe, connected to the bar feeder, is working and the bar is rotating into bar feeder guides.

In such a case, noise level emitted depends on the following conditions:

- perfect alignment and levelling of the lathe-bar feeder unit;
- proper fastening to the floor both of lathe and bar feeder;
- suitable bar gripping device fitted on lathe;
- dimensions of guide channel and bar-pusher suited to the bar stock;
- front guide bush of suitable diameter (if supplied);
- bar with a straightness within prescribed limits (max. arrows equal to 0.5 % of the bar length);
- spindle liner having the same diameter as the bar feeder guide channel diameter;
- spindle rotation speed suitable for the material to be machined;
- as to the bar feeder, use of oil having features suitable for the diameter of the bar to be machined;
- all bar feeder panels must be closed.

Should the above mentioned conditions be met, the noise level emitted during bar rotation into the guide channel, measured in compliance with the international standards, will be within the following limits:

- brass and steel round bars within 80 dbA
- hexagonal steel bars within 83 dbA
- brass hexagonal bars within 85 dbA

2.7 FITTINGS - FOREWORD

The bar feeder may be provided with the fitting that is described below to increase its performance and versatility.

2.7.1 Bush-holder device - Description

It is attached to the front part of the bar feeder. Its function is to reduce bar vibrations to a minimum, by keeping the bar centered during rotation through two half bushes A, which are coupled to form a round channel with a diameter just slightly larger than that of the bar being machined.

In many cases, this device can be used (by only changing the diameter of the half bushes) to greatly extend the range of diameters which can be machined without having to replace the guide channel.

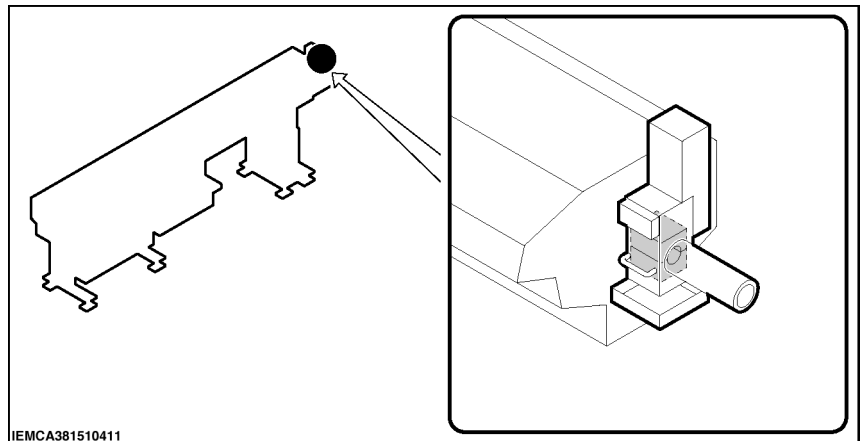

OPERATION

- When the bar is dropped into the guide channel, the two half bushes are open.
- Closure is controlled by a pneumatic cylinder after the feeder has completed the bar feeding cycle. Closure also controls lubricating oil flow for lubrication and machined bar support purposes.
- When the bar-pusher approaches the device, the half bushes open up to allow its passage; oil flow is then discontinued.

INDEX

3.1	GENERAL SAFETY PRESCRIPTIONS	2
3.2	HANDLING AND INSTALLATION - Safety.....	3
3.3	ADJUSTMENTS AND SETTING UP - Safety.....	3
3.4	USE AND OPERATION - Safety	4
3.5	BAR FEEDER MAINTENANCE - Safety.....	4

3.1 GENERAL SAFETY PRESCRIPTIONS



It is of the utmost importance to read this manual carefully before installing, using or servicing the bar feeder or performing any other work . Constant compliance with the instructions in this manual is a guarantee of protection against injury.

- The operator and skilled engineer must perform only their specified duties.
- Do not tamper with the safety devices for any reason whatsoever.
- Comply strictly with the work health and safety regulations issued by the relevant authorities in the country of installation of the machine.
- IEMCA declines any liability whatsoever for injury to persons or damage to property if the relevant safety prescriptions are disregarded.

3.2 HANDLING AND INSTALLATION - Safety

- The bar feeder must be handled using suitable means and methods.
- Persons must not stand or transit underneath a suspended load, or within the range of action of the crane, lift truck or other suitable means of lifting and transportation.
- The working area and bar loading area must be cordoned off to prevent collisions between the operator and machines used to transport or handle the barstock or other materials.
- Correct positioning of the bar feeder, adequate lighting and a clean working environment are of the utmost importance as far as personal safety is concerned.
- The electric system connection must be made exclusively by skilled electricians.
- Make sure the electrical system is connected to an efficient earth circuit by means of a dedicated wire.

3.3 ADJUSTMENTS AND SETTING UP - Safety

- Carry out the adjustments as described in the user manual.
- Do not change working parameters to obtain performances other than those envisaged in the design and testing phases.
- Do not adjust the bar feeder when it is running unless expressly requested to do so in the manual.
- Do not feed the machine with bars having dimensions different from those recommended by the manufacturer.
- Do not use hoses as handholds.







3.4 USE AND OPERATION - Safety

- The working area around the bar feeder must always be kept clean and uncluttered in order to allow immediate access to the emergency devices and bar loading to be performed without creating obstructions or danger.
- Perform the cycle starting sequence as prescribed.
- Keep hands and other parts of the body well clear of moving parts or live electrical parts.
- Remove bracelets, watches, rings and neckties.
- Whenever necessary, use strong work gloves with 5 fingers, which do not reduce the sensitivity or power of your grip.
- Wear working shoes as well as personal protection devices provided for by the accident prevention regulations in force in the country in which the machine is installed.
- Inform maintenance personnel of all operating anomalies that come to your attention.
- Before starting the bar feeder, make sure that there are no personnel engaged in servicing or cleaning the machine.

3.5 BAR FEEDER MAINTENANCE - Safety

- Do not allow unauthorized persons to carry out maintenance.
- Read this manual carefully before carrying out maintenance.
- Do not lubricate, repair or adjust the bar feeder while it is running, unless expressly indicated to do so in the manual.
- Stop the bar feeder in accordance with the prescribed methods before carrying out lubrication or other work.
- Do use matches, lighters or torches when servicing the machine in the presence of inflammable fluids.
- Keep spent oil in suitable containers and consign it to companies specialized in the storage and disposal of polluting waste products.
- Do not pollute the environment.
- Use original IEMCA spare parts only.

INDEX

4.1	PACKAGING	2
4.2	LIFTING 	2
4.2.1	Bar feeder without packaging - Lifting.....	3
4.2.2	Bar feeder with pallet - Lifting	4
4.2.3	Bar feeder with case - Lifting	4
4.3	INSTALLATION AREA - CHARACTERISTICS 	5
4.4	INSTALLATION OF THE BAR FEEDER - INTRODUCTION.....	6
4.4.1	Support plates and feet - Installation	6
4.4.2	Height - Adjustment	6
4.4.3	Preliminary positioning	8
4.4.4	Sleeve - Installation.....	9
4.4.5	Levelling and alignment.....	10
4.4.6	Feeder fastening	15
4.5	LUBRICATING OIL - FILLING 	16
4.6	ELECTRIC CONNECTION 	16
4.7	PNEUMATIC CONNECTION 	17
4.8	SOFTWARE PARAMETRING 	17

4.1 PACKAGING

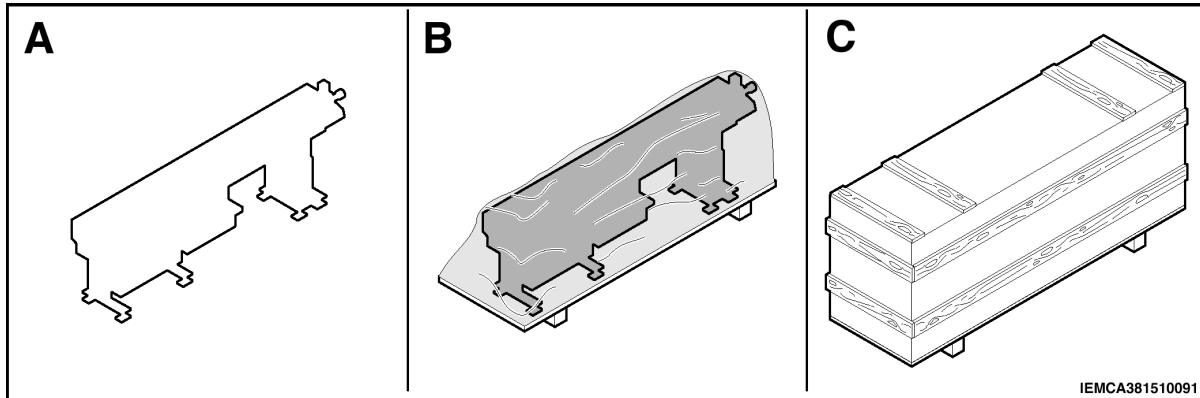

There are three possible bar feeder packagings:

- A WITH NO PACKAGING.
- B WITH PALLET: the feeder is placed on a pallet and wrapped in protective film.
- C WITH CRATE: the feeder is placed in a crate wrapped in protective film.

4.2 LIFTING



DANGER - WARNING:

e lifting and handling are to be done with proper means (see weight table, paragraph 2.6.) and by skilled staff, trained for this kind of manoeuvres.

- 4.2.1 Bar feeder without packaging - Lifting
- 4.2.2 Bar feeder with pallet - Lifting
- 4.2.3 Bar feeder with case - Lifting

4.2.1 Bar feeder without packaging - Lifting

- Assemble the two crosspieces A supplied.
- Use a hooked lifting device of adequate capacity.



CAUTION-PRECAUTION:
during the lifting and installation phases pay special attention to the section housing the motor (B).

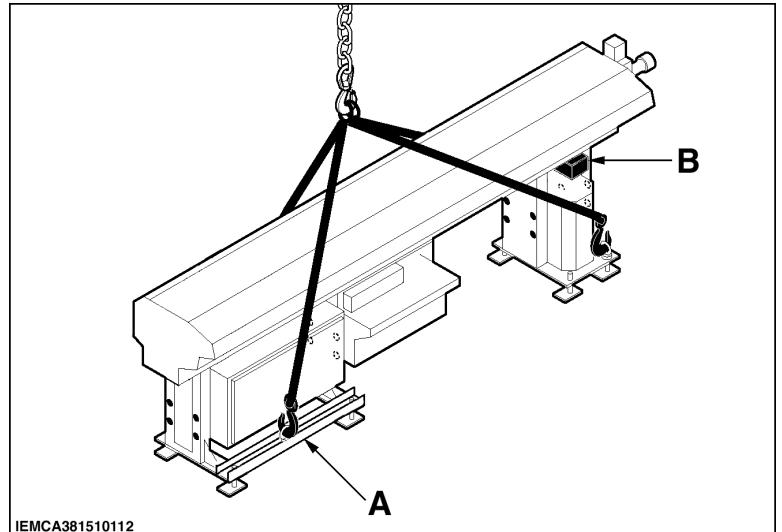

4.2.2 Bar feeder with pallet - Lifting

Use a hook lifting device of adequate capacity load.

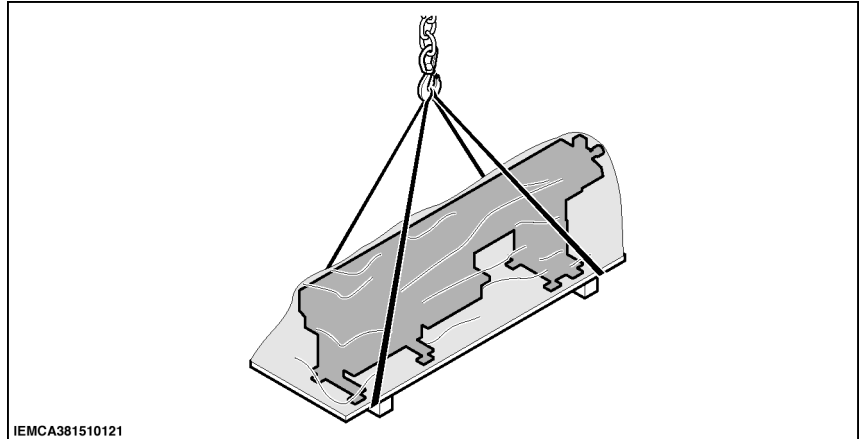

4.2.3 Bar feeder with case - Lifting

Use a hook lifting device of adequate capacity load.

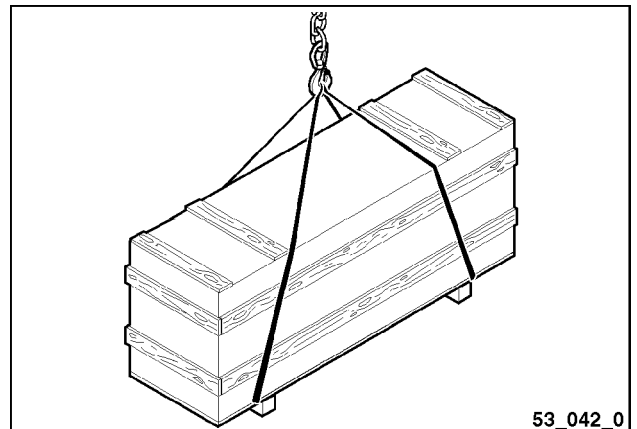

4.3 INSTALLATION AREA - CHARACTERISTICS

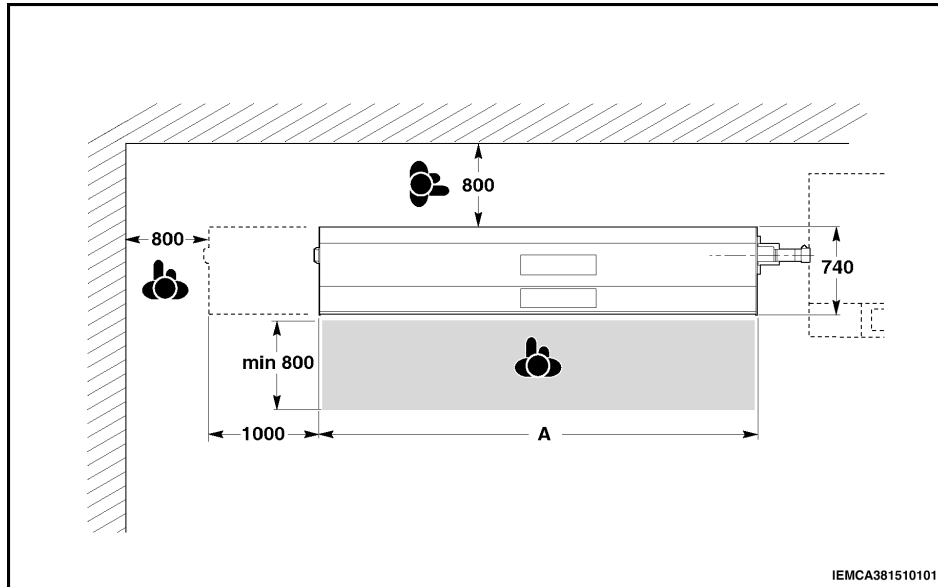

The floor should be stable and levelled to guarantee good fastening to the ground. Provide an area of suitable dimensions according to the type of feeder use. The area: A (work area, bar feeding area, remnant discharge area) should be properly delimited to prevent collisions between the operator and any handling equipment or transport vehicles travelling near the bar feeder. The selected bar feeder setting should be suitably lit and provided with an electric power and air outlets. During operation, the feeder will release small amount of oil vapors. Make sure that the premises where the feeder is installed are suitably ventilated. The feeder has not been designed and built for use in an explosive atmosphere.

Model	Version	A (mm)
MASTER 880 MP Evolution	33	4000
	38	4500
	43	5000

4.4 INSTALLATION OF THE BAR FEEDER - INTRODUCTION

Before carrying out feeder installation, check lathe stability; make sure that it is firmly fastened to the ground and with a horizontal spindle axis.

4.4.1 Support plates and feet - Installation

- Position the feeder next to the lathe.
- Keep it lifted and install the plates (A).

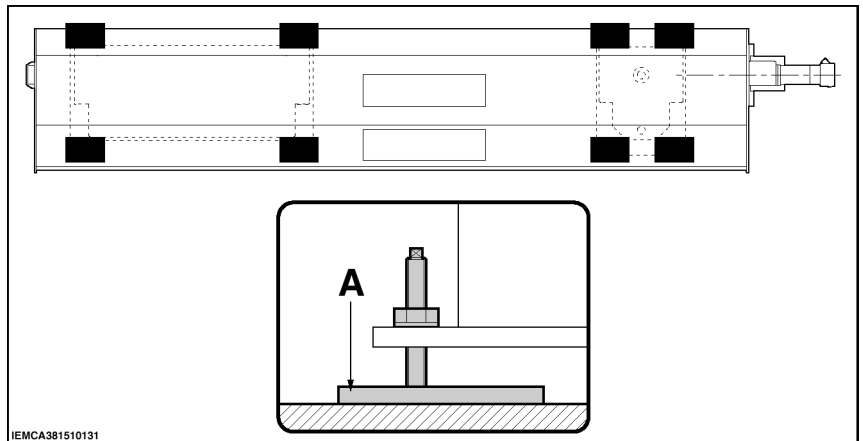

4.4.2 Height - Adjustment

The feeder is normally factory-preset to have a working axis height adjusted to lathe height. However, if feeder height needs adjustment, proceed as follows:

- stretch the lifting belts and remove screws (C) in the front and rear bases;



CAUTION-PRECAUTION:

during the lifting and installation phases pay special attention to the section housing the motor (B).

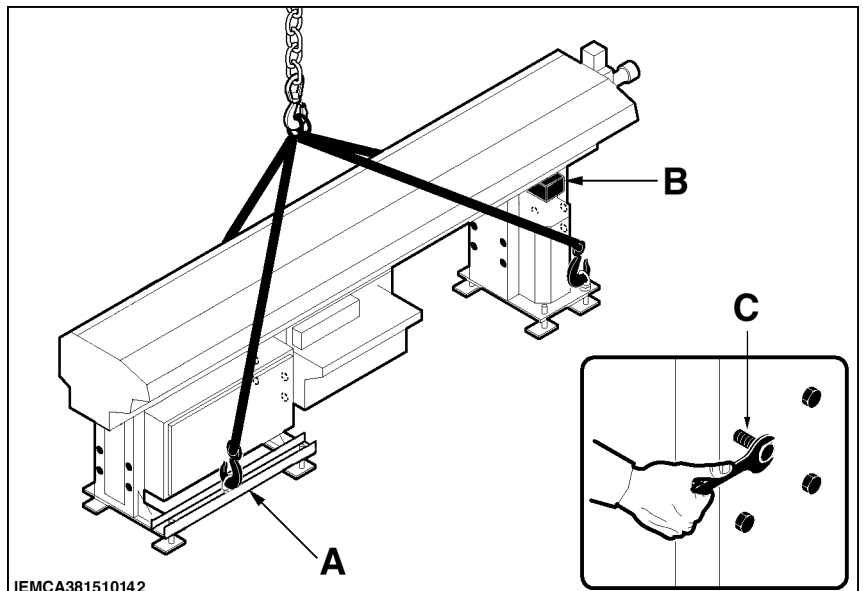

- lift or lower the bar feeder according to necessary value X, see table.

Table 2. Working axis height

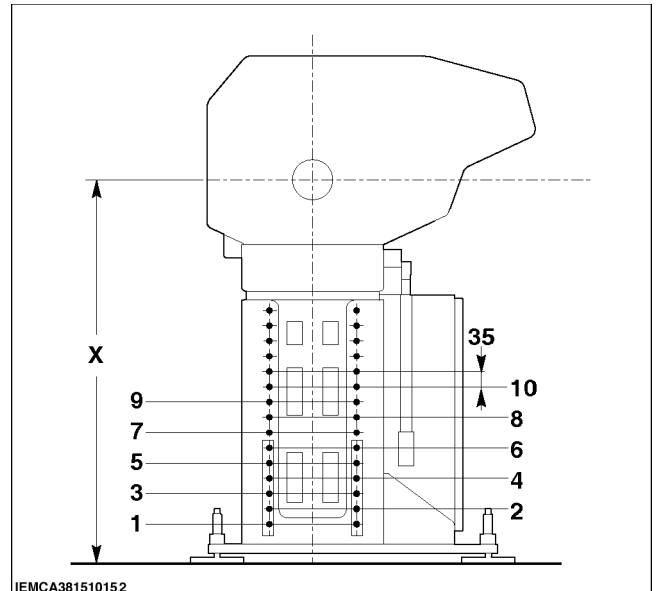

Model	Upper screws position	X (mm)
MASTER 880 MP Evolution	1	865÷899
	2	900÷939
	3	940÷969
	4	975÷1009
	5	1010÷1044
	6	1045÷1079
	7	1080÷1114
	8	1115÷1149
	9	1145÷1179
	10	1180÷1220

- tighten screws (A); remove the cross-member and the eyebolts utilised for lifting purposes.

4.4.3 Preliminary positioning

- Position the feeder behind the lathe, by taking into account the overall dimensions and side plays of both machines. The coupling distance (B) should not exceed the bar-pusher max. extension (A).

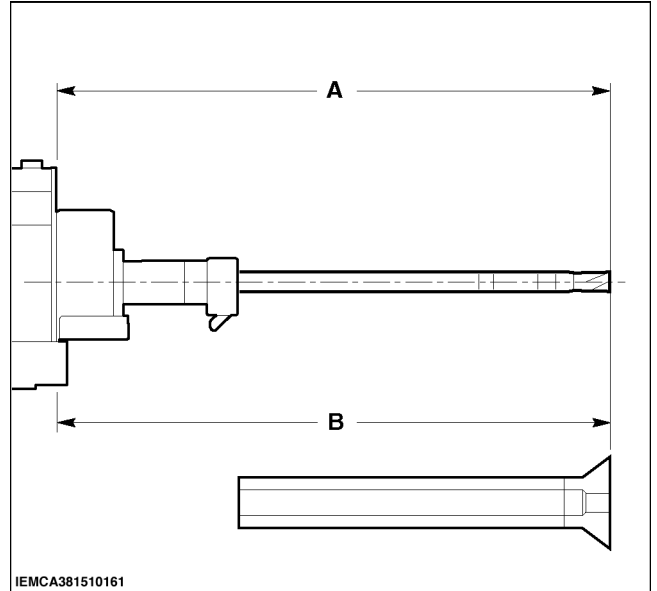
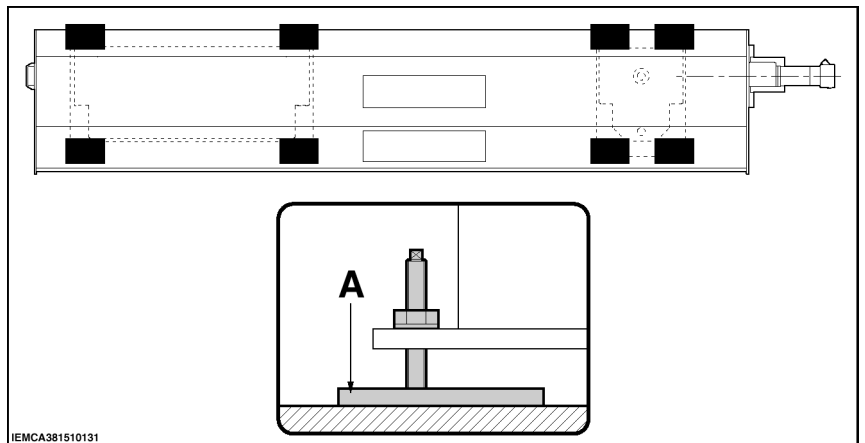

Table 3. Max. bar-pusher extension

Model	Version	Version	A - Max. extension (mm)
MASTER 880 MP Evolution	33-38-43	L	1350
	38-43	LL	1600
		XLL	1850

- Roughly adjust the height of the working axis and the alignment with the lathe by turning the screws of plates A.



4.4.4 Sleeve - Installation

- Install the sleeve (A) in the bush holder device.
- Install the oil recovery device (B).
- Connect lubrication line (C) to the feeder nose.
- Connect the drain pipe (D) to the tank.

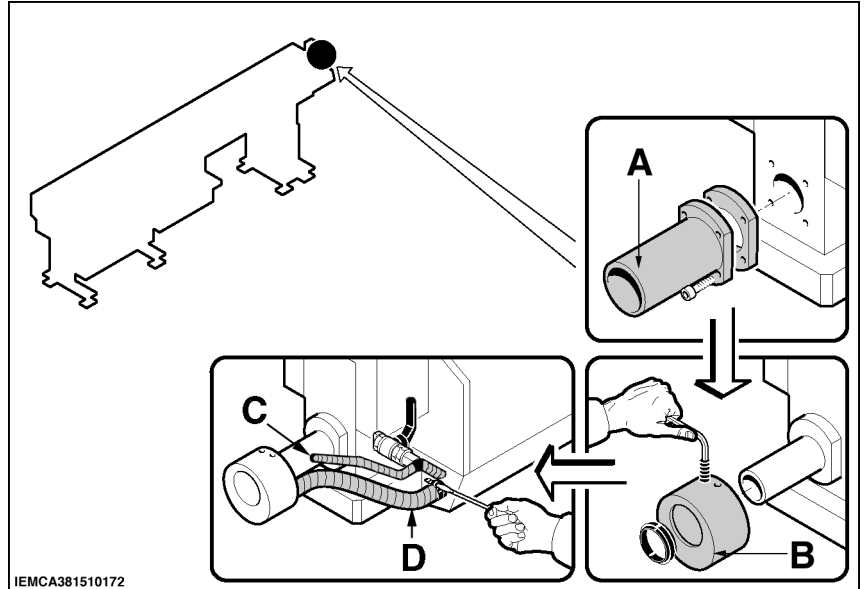

4.4.5 Levelling and alignment

FOREWORD

Alignment between the feeder and lathe is the most critical installation phase; therefore, this operation should be carried out by experienced personnel with the greatest accuracy.

**CAUTION:**

bad alignment can be the main cause of feeder malfunction and resulting damage.

**CAUTION:**

do not operate manually (i.e. using the special crank) when the electric power is connected.

PRELIMINARY PROCEDURE

- Open the upper guard.

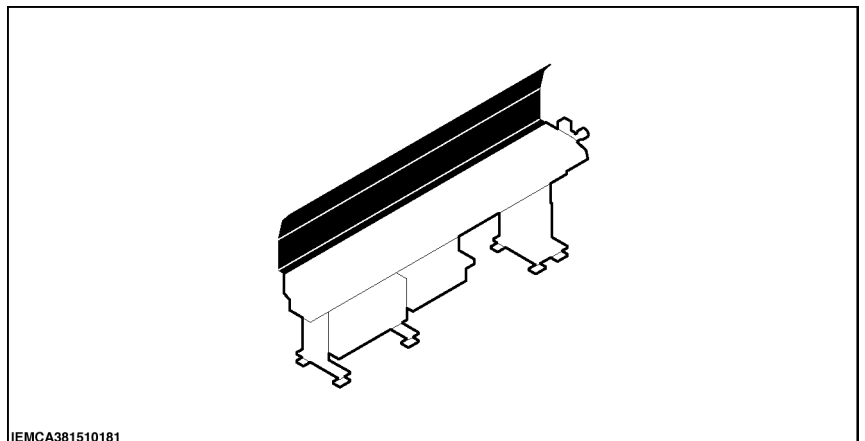

- To bring the bar pusher to its fully retracted position, select manual mode and press key



or



on the keypad.

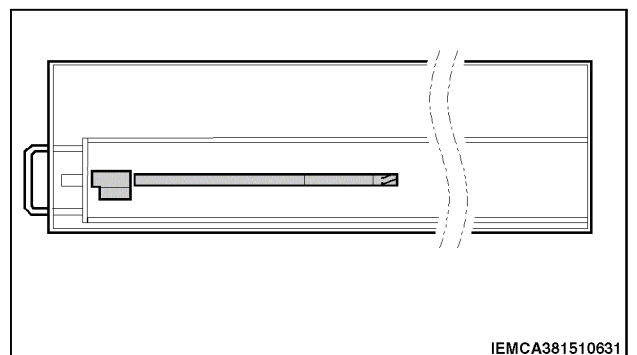

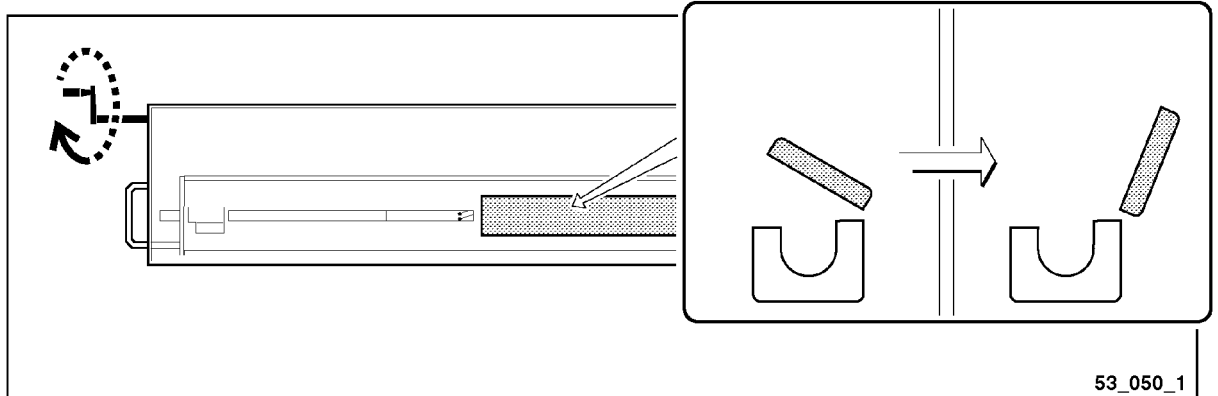

53_050_1

- Press key **SEMI AUT.** and repeatedly press key **STEP by STEP** until the upper guide channels open.
- Remove the first and the last lower guide channel by using the special wrench provided for the purpose.

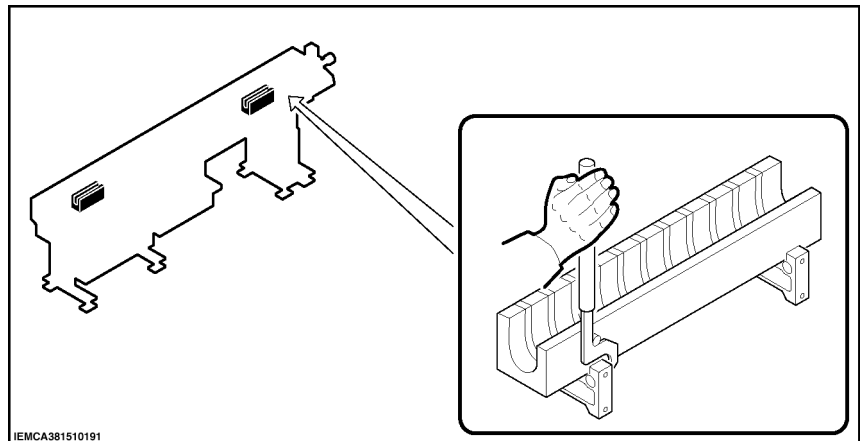

IEMCA381510191

LEVELLING

- Rest provided shelf on (A) supports.
- Check the levelling by placing the level crosswise and lengthwise.

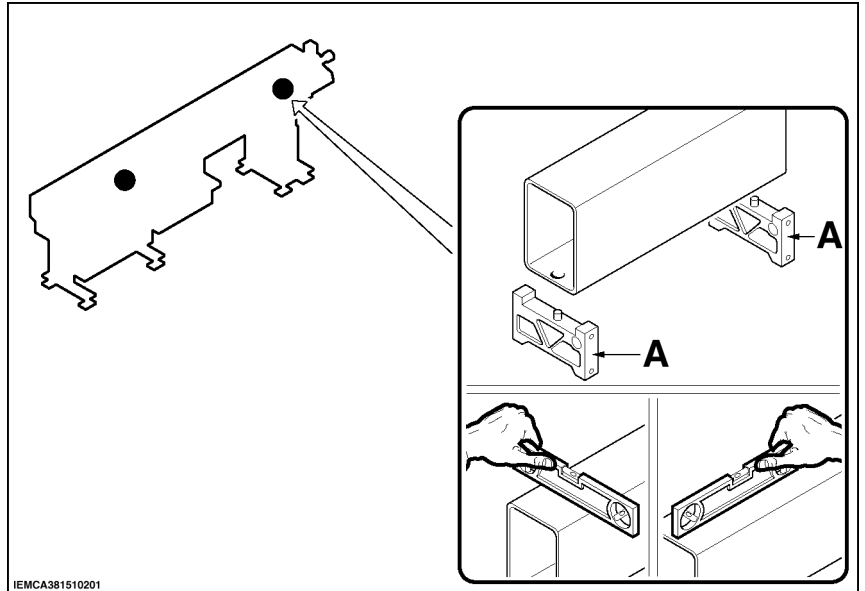

- Carry out the required connections by turning the feet (A) and (B) screws.

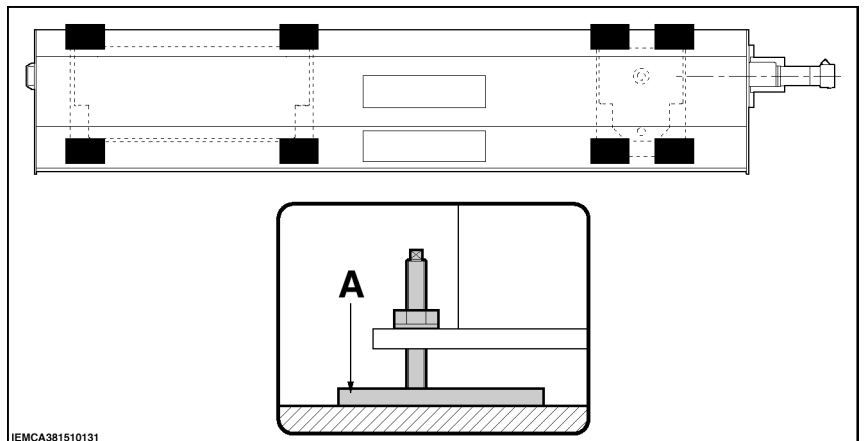

ALIGNMENT

Alignment is obtained by interposing a nylon yarn (\varnothing 1 mm) between the lathe collet and the first feeding carriage, by proceeding as follows:

- place a pierced bushing (A) in the lathe collet;
- stretch the yarn between the bushing and the hole in the 1st feeding carriage (B).

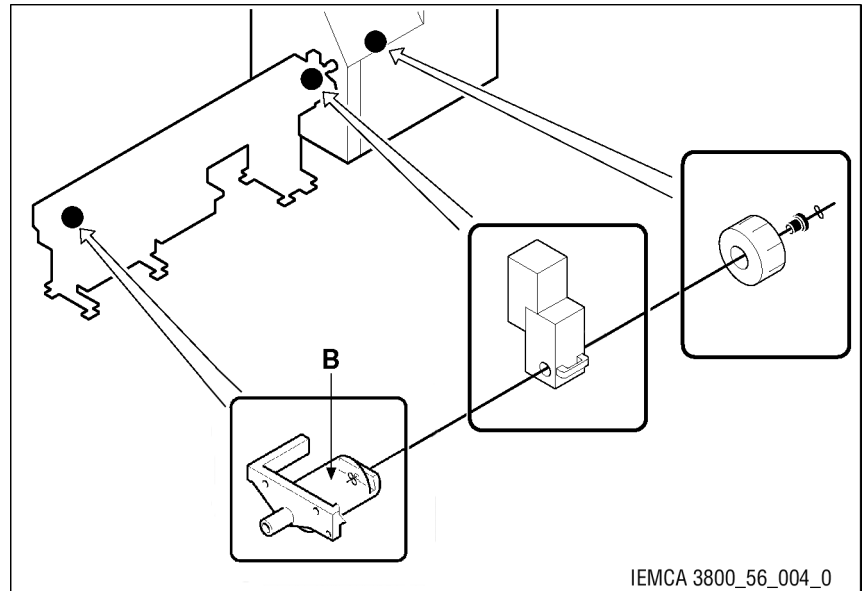

IEMCA 3800_56_004_0

- use a sliding calliper to check alignment near the sleeve (C) and the spindle (D); adopt a tolerance of 0.15 mm in all four directions.

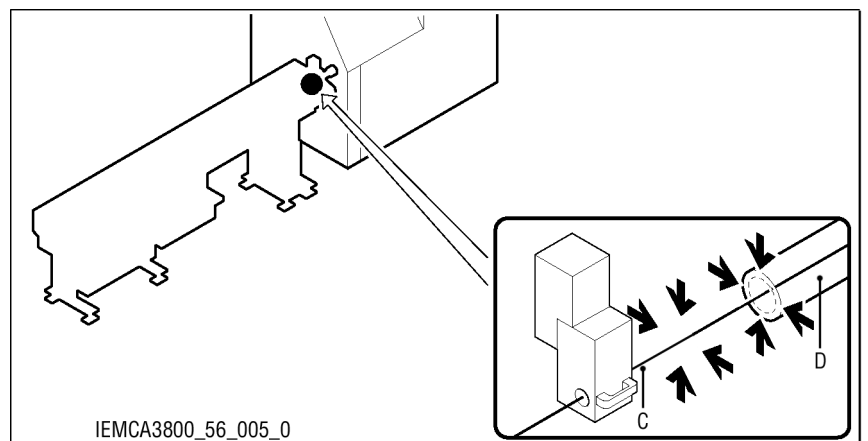

IEMCA3800_56_005_0

It is also possible to carry out alignment by placing a bar in the guides. Proceed as follows:

- prepare a perfectly straight ground bar, having an outside diameter equal to the max. spindle bar passage and a length equal to twice the coupling distance (see item B paragraph 4.4.3);
- place the bar in the guide and cause it to slide forwards and backwards in the spindle, until almost reaching the lathe collet area.

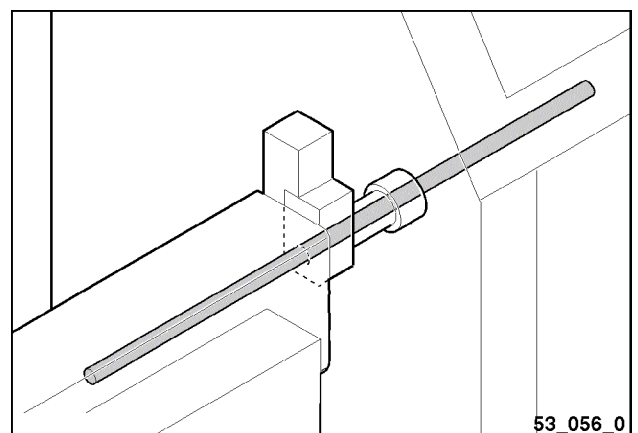

53_056_0

POSITIONING ADJUSTMENTS

After checking alignment of the feeder with either the thread or the bar, any required corrections should be carried out.

Adjust height by turning the (A) and (B) screws in the support feet; carry out lateral adjustment with calibrated mallet blows on the sides of plates (C).

During this phase, any adjustment carried out during levelling should be preserved; therefore, in most cases, feeder positioning will be the result of a good adjustment compromise.

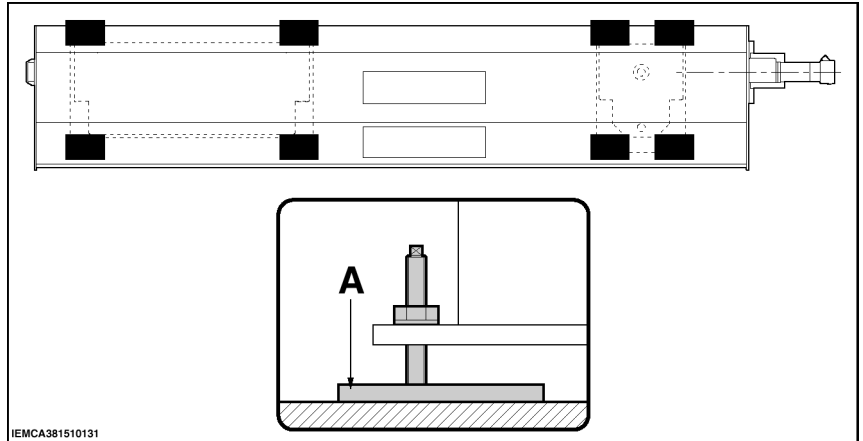

4.4.6 Feeder fastening



CAUTION:

failure to fix the bar feeder to the ground or bad bar feeder fixing to the ground can be the main cause of bar feeder bad operation and resulting damaging.

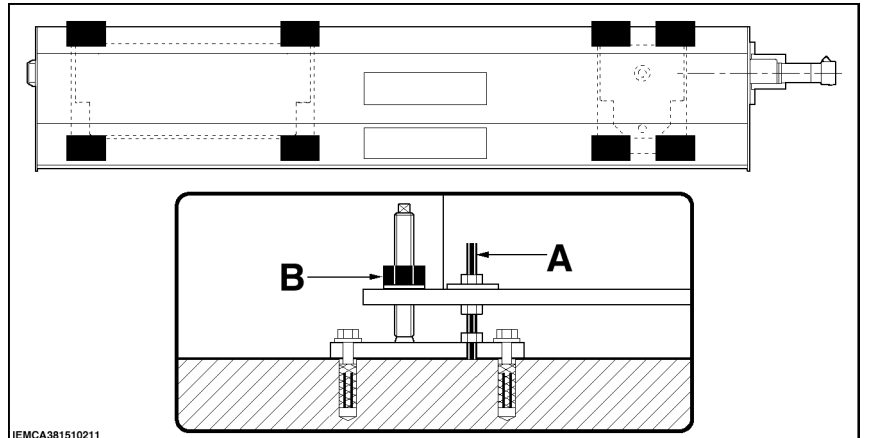

- Drill the floor and fix the backing plates with expansion plugs. Drill the floor and fix the backing plates with the expansion plugs. Use the highest possible number of plugs in order to guarantee good fixing.
- Fix the feeder to the plates through the tie-rods A and lock with nuts B.
- Perform another levelling and alignment check.
- Remove all the equipment used for levelling and alignment and restore initial feeder conditions.

4.5 LUBRICATING OIL - FILLING

**CAUTION:**

wear personal protections according to the regulations in force.

- Pour the oil directly into the tank and check the level through the relevant indicator (A).

Oil characteristics: Class C - CKB 150, amount 80 l.
See paragraph 2.6. for the comparative table.

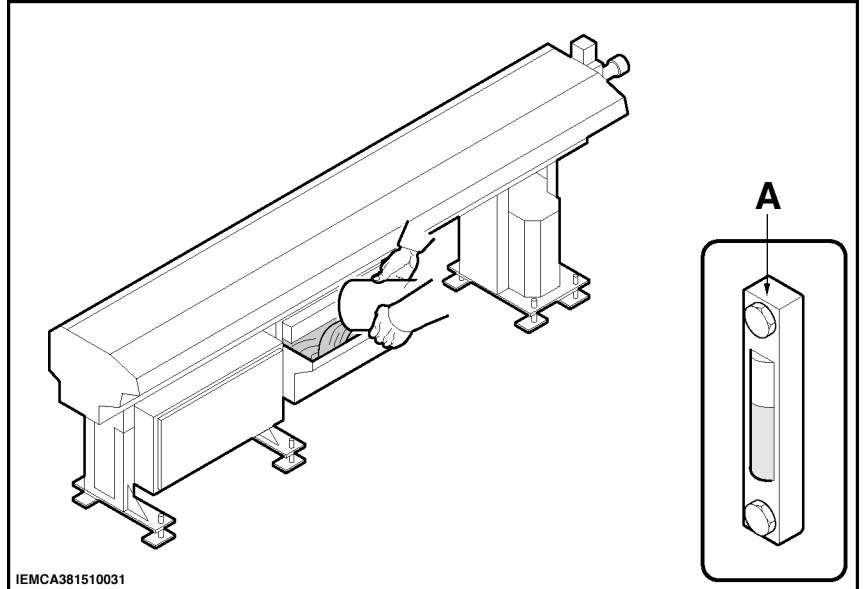

4.6 ELECTRIC CONNECTION

**DANGER - WARNING:**

this type of operation should only be entrusted to skilled technical staff to comply with the applicable standards and statutory regulations in force.

The feeder must be electrically connected to the lathe, which in turn, must be connected to the plant wiring system in compliance with the applicable regulations in force.

The feeder is normally provided with a multiple plug to plug into the special lathe outlet; refer to the "Wiring diagram" if necessary.

4.7 PNEUMATIC CONNECTION

- Connect pipe (H) to the compressed air ductwork system as shown in the figure.



CAUTION - PRECAUTION:
*to adjust pressure, follow the directions
 in section 7.2.3.*

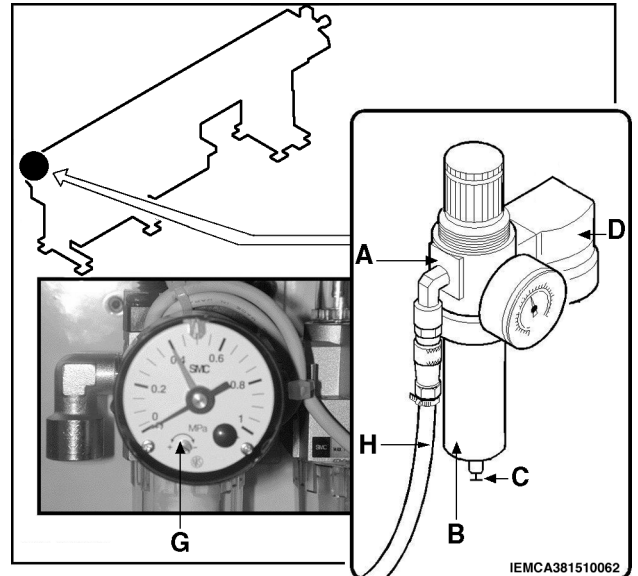



4.8 SOFTWARE PARAMETRING

There should be an adequate parametring of the bar feeder software according to the working needs and to the type of lathe.

For information on this operation, refer to the "Keyboardf panel instruction manual".

INDEX

5.1	INTRODUCTION TO ADJUSTEMENTS AND SET-UP - FOREWORD 	2
5.2	GENERAL ADJUSTMENTS - FOREWORD 	2
5.2.1	Feeding chain - Adjustment	3
5.2.2	Setting the pressure switch	3
5.3	BAR FEEDER SETTING UP 	4
5.3.1	Guide channels, half-bushings, bar pusher and collet - Replacement	5
5.3.2	Adjusting the bar selectors	12

5.1 INTRODUCTION TO ADJUSTEMENTS AND SET-UP - FOREWORD **DANGER - WARNING:**

do not adjust while the bar feeder is running, unless it is explicitly stated in the manual.

This bar feeder also requires - besides the ordinary adjustments necessary during its life - setting ups depending on the bar dimensions and the type of bar magazine. Such interventions are listed and explained as follows.

**5.2. General adjustments
5.3. Bar feeder setting up****5.2 GENERAL ADJUSTMENTS - FOREWORD **

All adjustments necessary for the bar feeder good operation are meant. They can be necessary for maintenance and as a cure to a trouble, or they can be required after a component replacement.

**5.2.1 Feed chain - Adjustment
5.2.2 Setting the pressure switch**

5.2.1 Feeding chain - Adjustment

- Adjust the chain tension through screw (A).

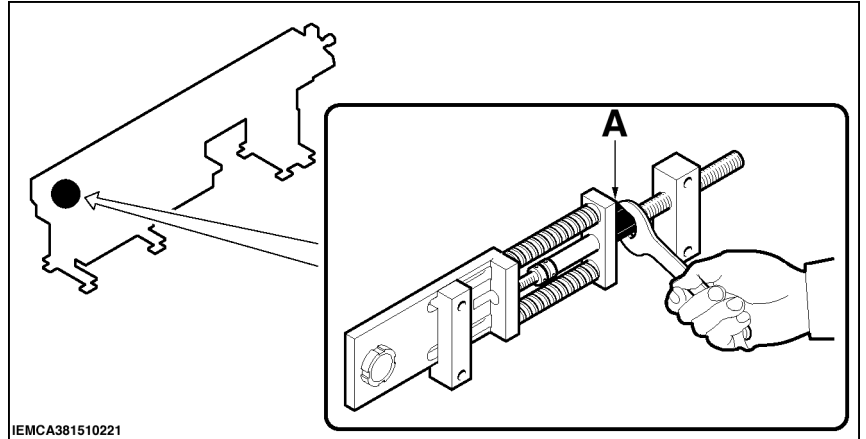

- The distance (C) (among the ring nuts D and plate E) should be equal to 0 mm. Operate ring nuts (D) in case an adjustment is needed.
- Restore the bar feeder initial conditions.

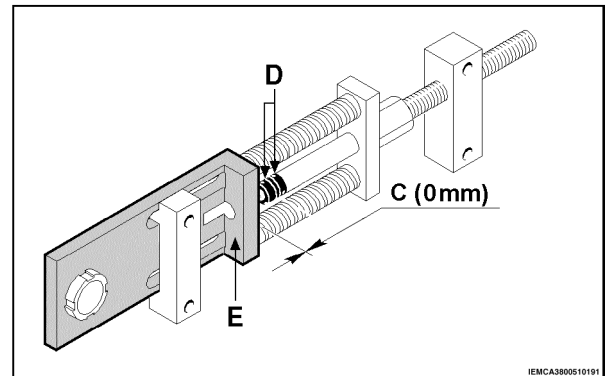

5.2.2 Setting the pressure switch

After unscrewing the glass protection, the pressure switch can be properly adjusted by turning the relevant adjusting screw (G). Proper setting is 4.5 bars (0.45 MPa).



CAUTION:

Do not further turn anti-clockwise when the green pointer is found on 0, as this may cause damage to the pressure switch.

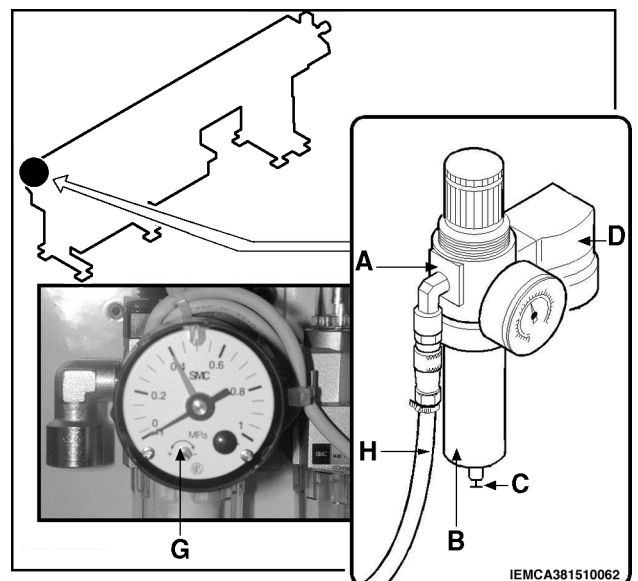

5.3 BAR FEEDER SETTING UP

Some interventions are necessary, depending on the bar diameter of the previous machining in relation to the diameter of the "new" bar. The table reports the diameters of available guides as well as the range of the bar pushers that can be assembled, and the diameters of the bar to be machined.

Table 1. Guide channel, bar pusher, bar and tube diameters

Model	Guide channel diameter (mm)	Bar pusher diameter (mm)	Bar diameter		Tube diameter (mm) (*)
			Minimum	Maximum	
MASTER 880 MP Evolution	21	20	8	18	20
	26	25	8	23	25
	33 (**)	32	10	29	31
	36	35	10	32	35
	43	42	12	39	42
	46	45	15	42	45
	52	51	18	47	51
	57	56	22	52	56
	61 (**)	60	30	56	60
	66	65	38	61	65
	69	68	48	63	68
	71	70	48	65	70
	73	72	50	67	72
	76	75	50	70	75
	81	80	52	75	80
	86 (**)	85	55	80	80

(*) Valid also for prepared bars or normal bars machined with front remnant ejection.

(**) Recommended guide according to max lathe bar passage.

Example: $\varnothing 85$ max bar passage - GUIDES 86-61-33.

Example: $\varnothing 80$ max bar passage - GUIDES 81-61-33.

Example: $\varnothing 75$ max bar passage - GUIDES 76-61-33.





The bar feeder setting ups are listed and explained as follows.

5.3.1 Guide channels, half-bushings, bar pusher and collet - Replacement

5.3.2 Adjusting the bar selectors

5.3.1 Guide channels, half-bushings, bar pusher and collet - Replacement



- Push  to start the bar feeder.
- Push  plus  to select the semiautomatic function.
- Press  several times until top guide opening is obtained; the displayed message must be "GUIDE FULL OPENING" .

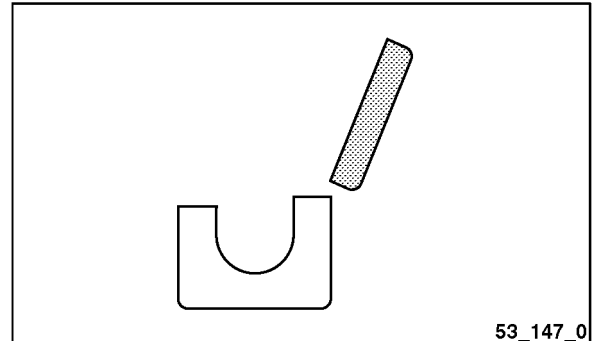

- Press  to open the top cover.

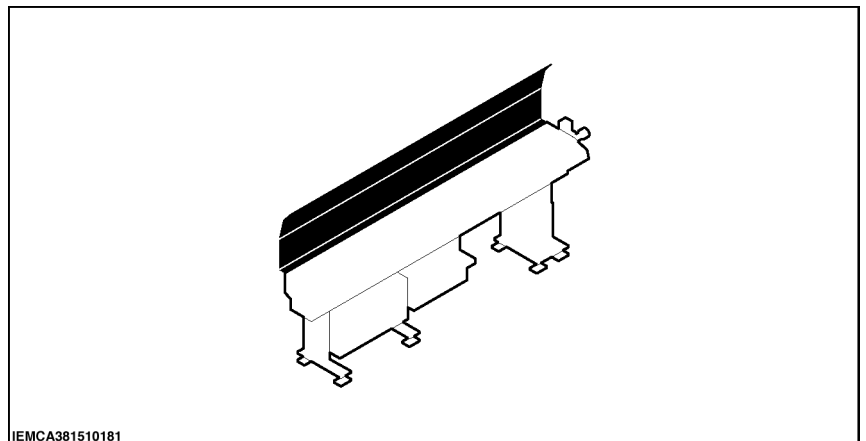

- Remove the bar pusher from the two supports.

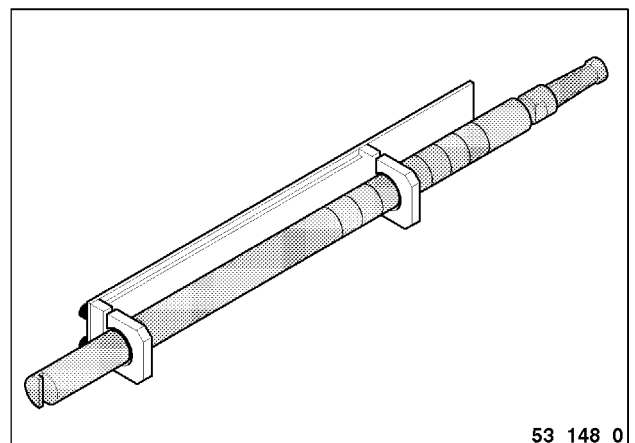

- Remove the block (A) and then, the first feeding carriage (B).

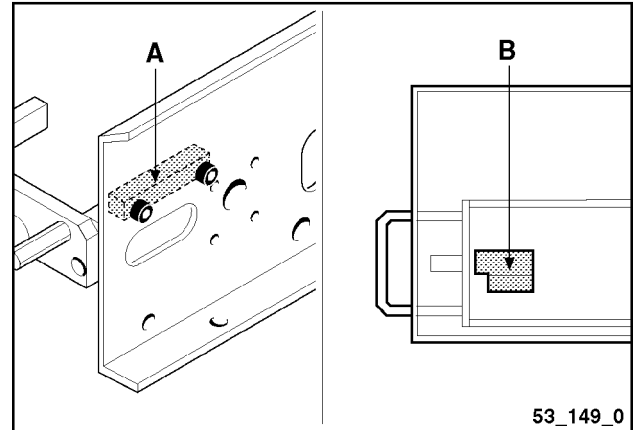

- Remove the lower guide channels by using the special wrench provided for the purpose.

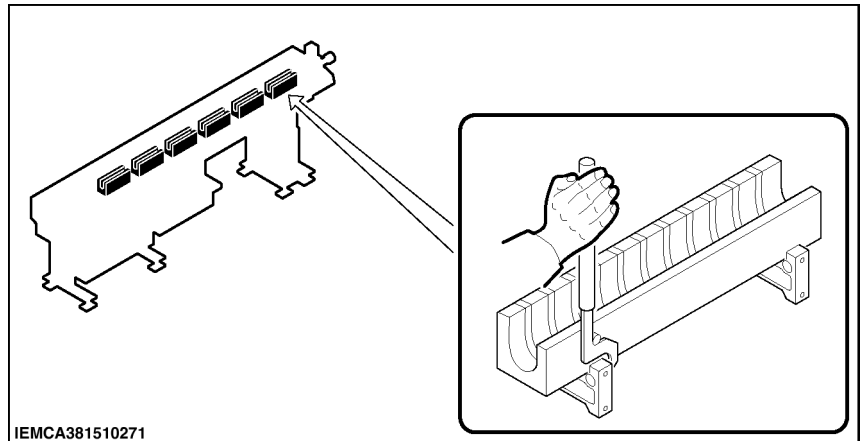

- Replace the bar pusher supports with those of the "new" diameter.

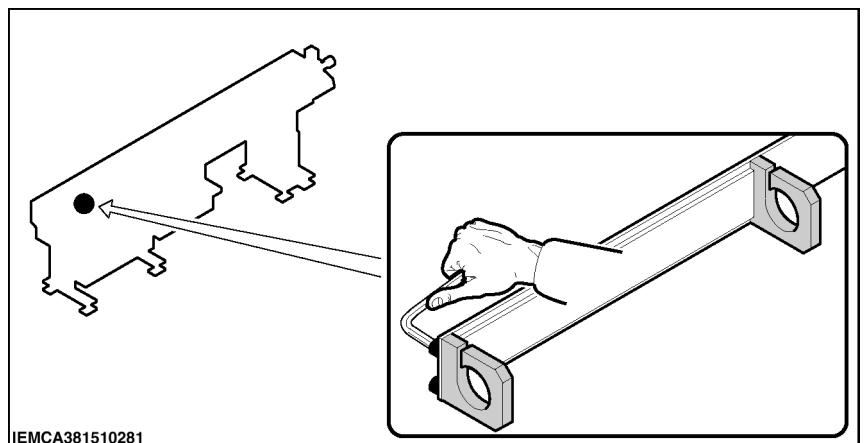

- Turn the screw counter-clockwise to move the feeder body backwards.

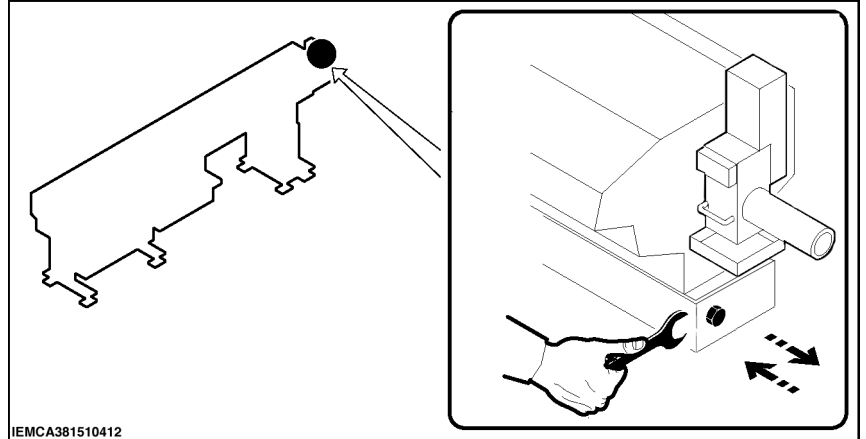

- Remove the oil recovery device (C) and nose (D).

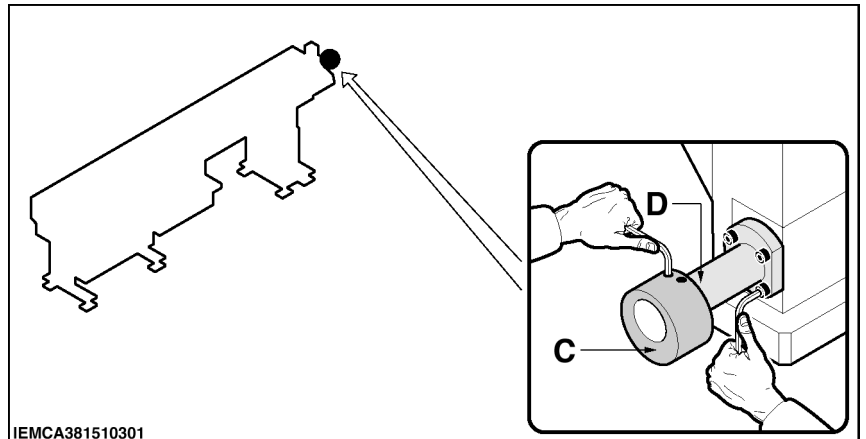

- Remove the cover, fully open the two half bushes by manually turning the shaft E and extract the lower half bush.
- Close the upper half-bushing using the shaft and replace it.
- Turn the shaft and fit the lower half-bushing.
- Fully close the half bushes and place the cover.

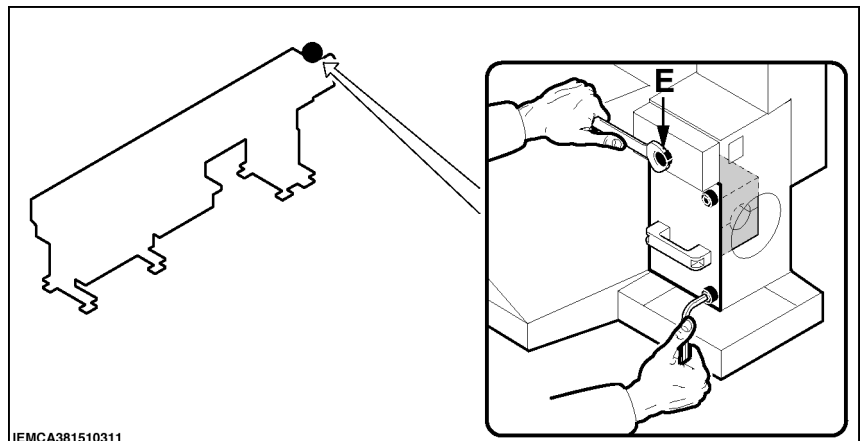

- Remove the lathe spindle liner if required and install a suitable liner for the "new" diameter.

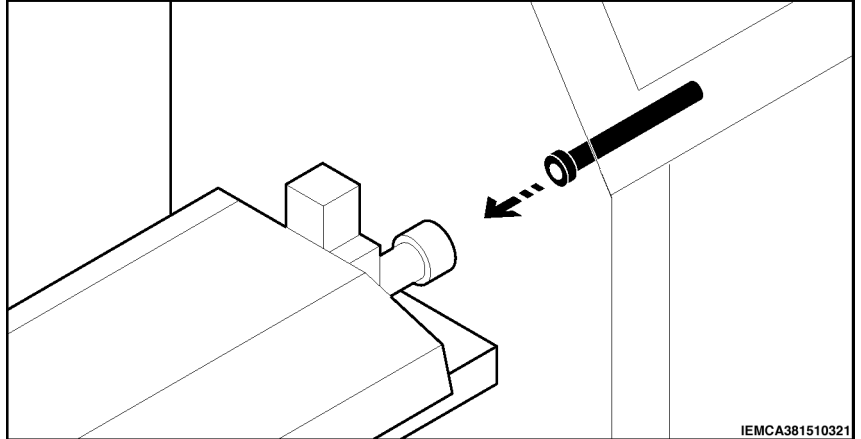

- Assemble sleeve (D) of the "new" diameter and the oil recovery (C).

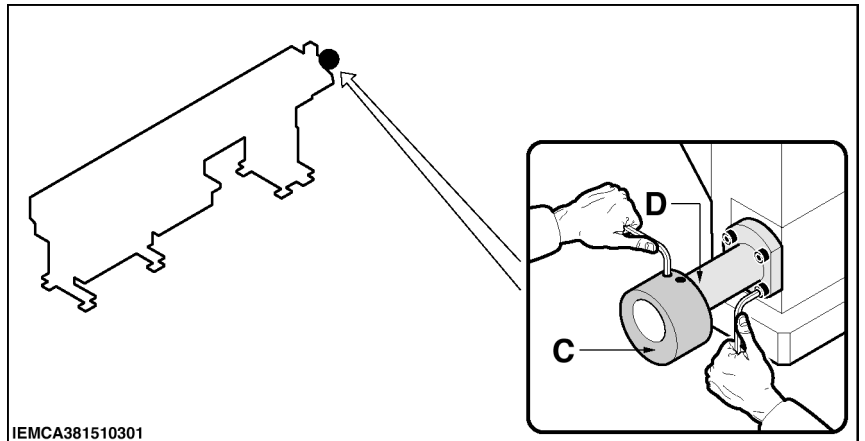

- Turn the screw clockwise to move the feeder body forwards.

CAUTION - PRECAUTION:
bring the body of the feeder up to the stop on the tank slowly, thereby eliminating the risk of damaging the traverse unit.

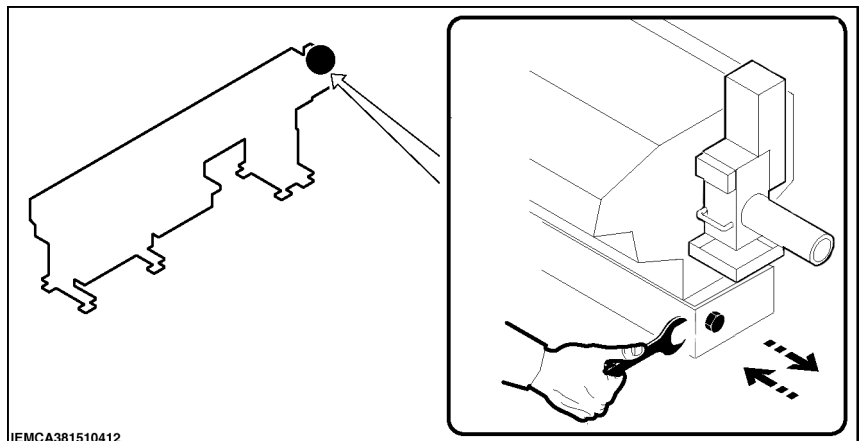

- Assemble the lower guide channels of the "new" diameter.

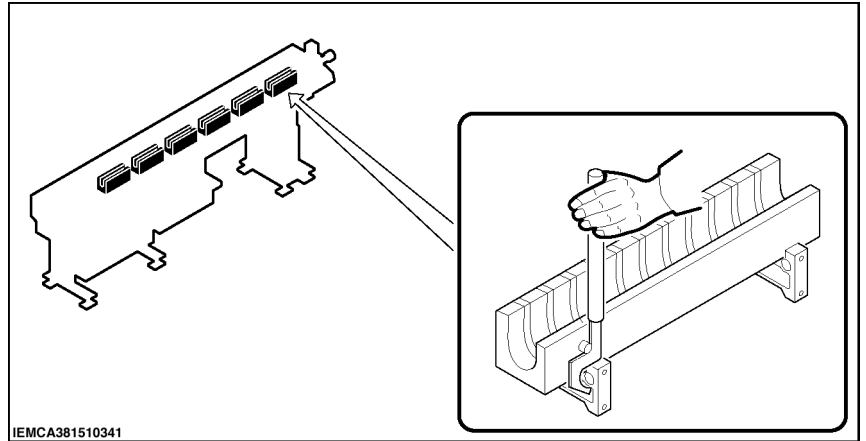

- Choose collet fit to bar diameter and profile; see "BAR PUSHER - GUIDES-COLLET - ROTARY GROUPS - Manual for the choice".

**INFORMATION:**

contact IEMCA After-Sales service for more information.

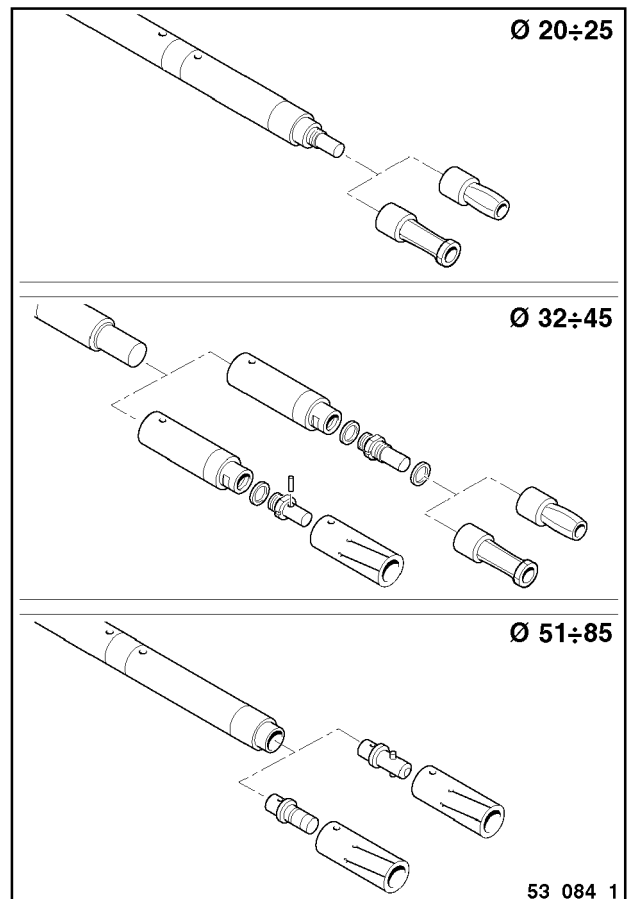

**CAUTION:**

the collet outside diameter should be at least 0.5 mm smaller than the bar-pusher outside diameter.

- Install the collet in the bar-pusher and make sure that the rings are riveted in their special recesses to prevent accidental collet unscrewing from its connection.
- Install a suitable 1st feeding carriage (B) for the new diameter, followed by the block (A).
- Insert bar pushers into two supports. Properly position bar pusher axially, so that (F) groove matches (G) support.

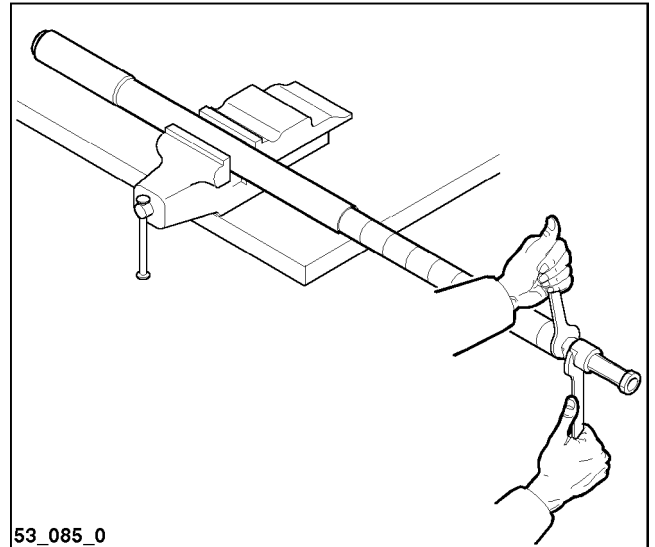

53_085_0

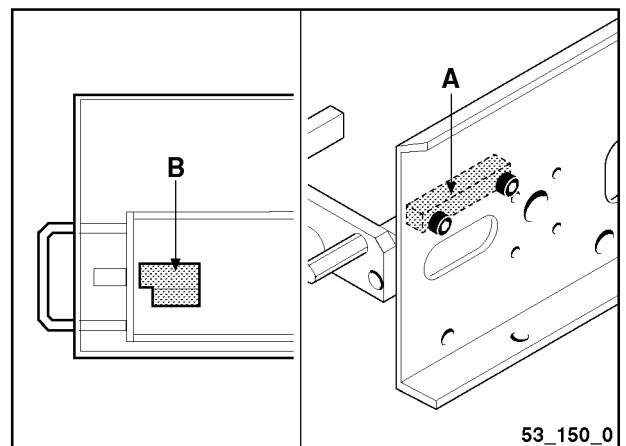

53_150_0

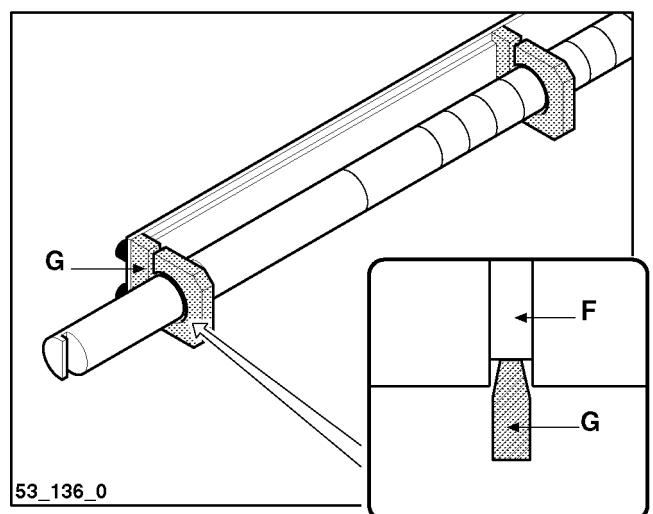

53_136_0

- Properly position bar pusher radially so that in next phase of upper guides locking, matching between bar pusher and (B) 1st feeding carriage occurs correctly.



CAUTION:

The above mentioned positioning has to be assured. Therefore during set-ups or maintenance operations, if bar pusher is struck involuntarily, it has to be correctly repositioned.

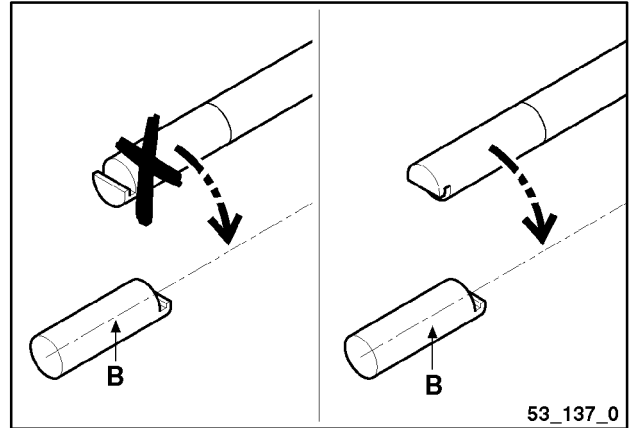

53_137_0

- Press  for partly close the top guides.

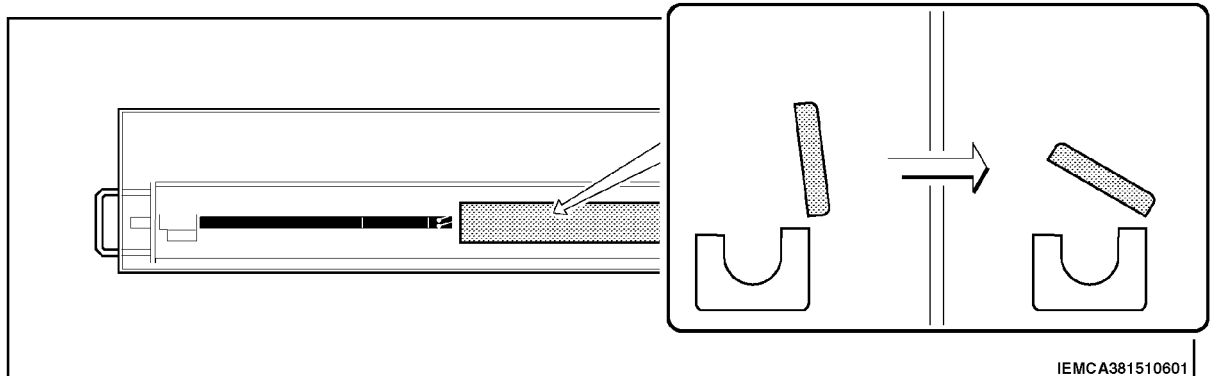

IEMCA381510601

- Loosen all the elastic clamps H (Socket screw key CH6 supplied).

- Close the top guides () until the sensor (D) comes on. By executing this operation, you will cause the top guides to rest against the lower guides. Tighten all the clamps (H).

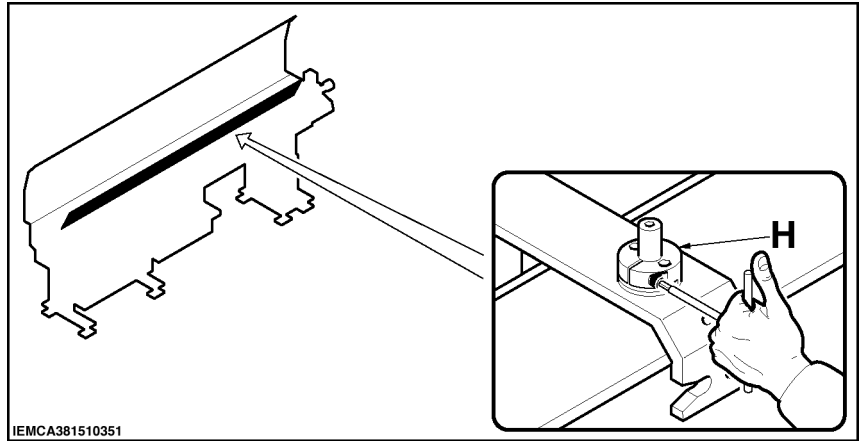

IEMCA381510351

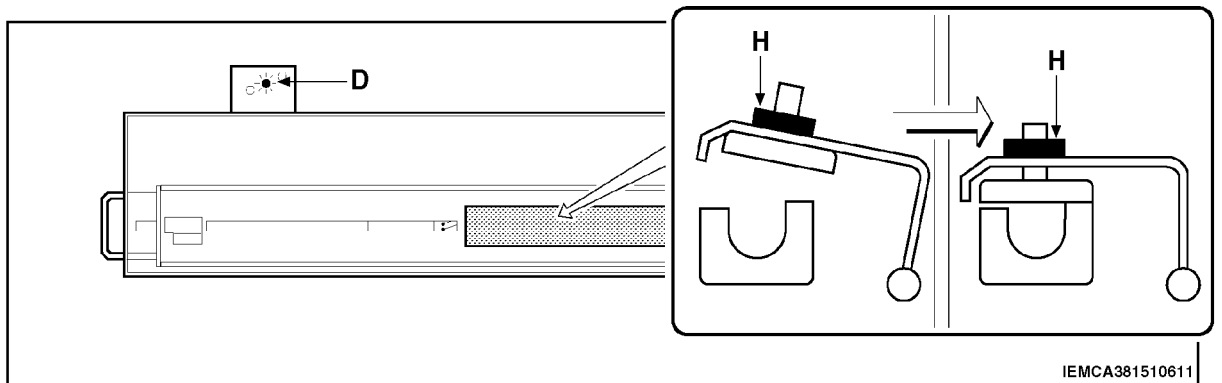

IEMCA381510611

5.3.2 Adjusting the bar selectors

- Properly position selectors A, so that only the first bar B is found along the path followed by lifts C during their travel.

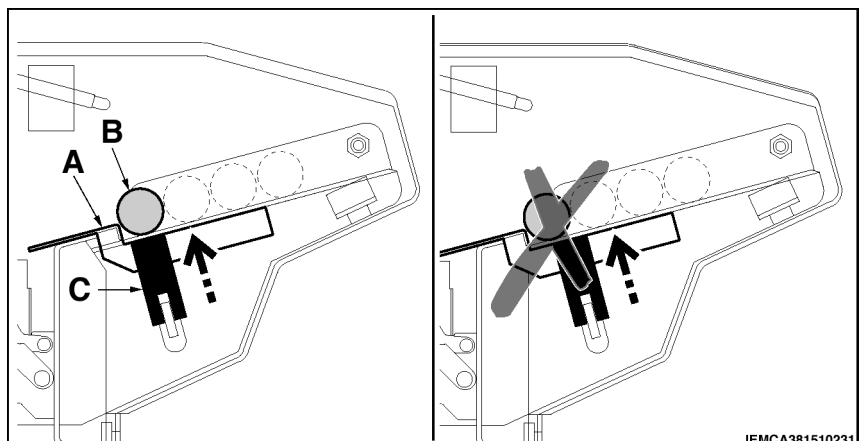

IEMCA381510231

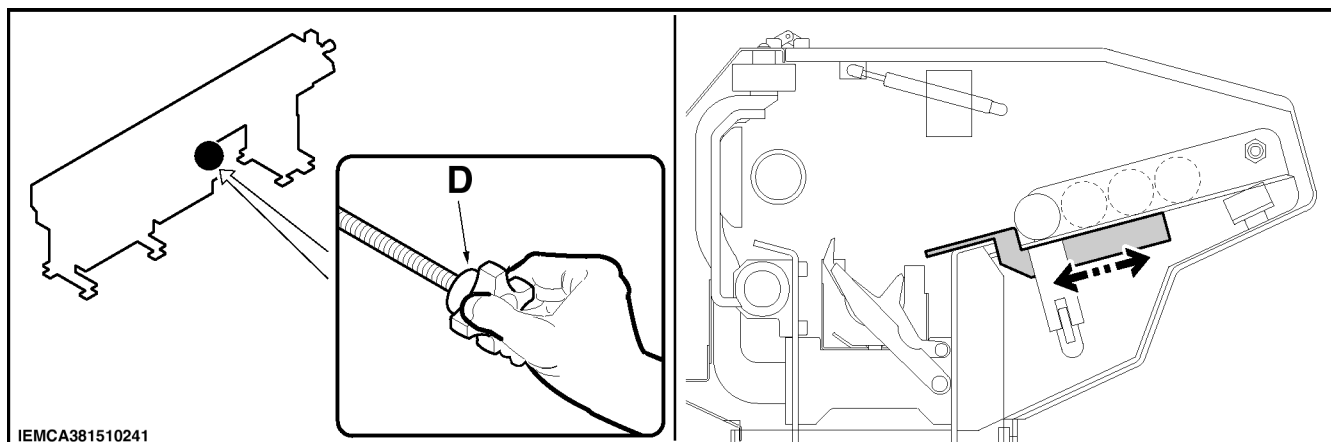

- Work on knob D for adjustment.

INDEX

6.1	DESCRIPTION OF THE CONTROLS	2
6.2	DESCRIPTION OF KEYBOARD CONTROLS	4
6.3	LUMINOUS INDICATOR - SIGNAL DESCRIPTION	7
6.4	BAR FEEDER SETUP	7
6.5	BARS TO BE MACHINED - CHARACTERISTICS AND PREPARATION	8
6.5.1	BAR STRAIGHTNESS - Measurement	10
6.6	BAR MAGAZINE - LOADING.....	11
6.7	AUTOMATIC CYCLE START	12
6.8	BAR LOADING - PROCEDURE	13
6.9	LUBRICATION OIL - FLOW ADJUSTMENT.....	14
6.10	BAR FEEDER STOP.....	14
6.11	CYCLE EXECUTION MODE IN THE "STEP-BY-STEP" FUNCTION.....	15

6.1 DESCRIPTION OF THE CONTROLS



INFORMATION:

from the hand-held keyboard it is possible to start automatically the bar feeder, even when lathe 'MAN/AUT' signal is in Manual mode.



INFORMATION:

When Automatic mode is on, the bar feeding is possible only when lathe 'MAN/AUT' signal is in Automatic mode.



INFORMATION:

Pressing Manual mode button it is possible to prevent the bar feeder automatic start by the lathe.

The illustration shows the positions of both the electrical controls and hand-held keyboard "1".

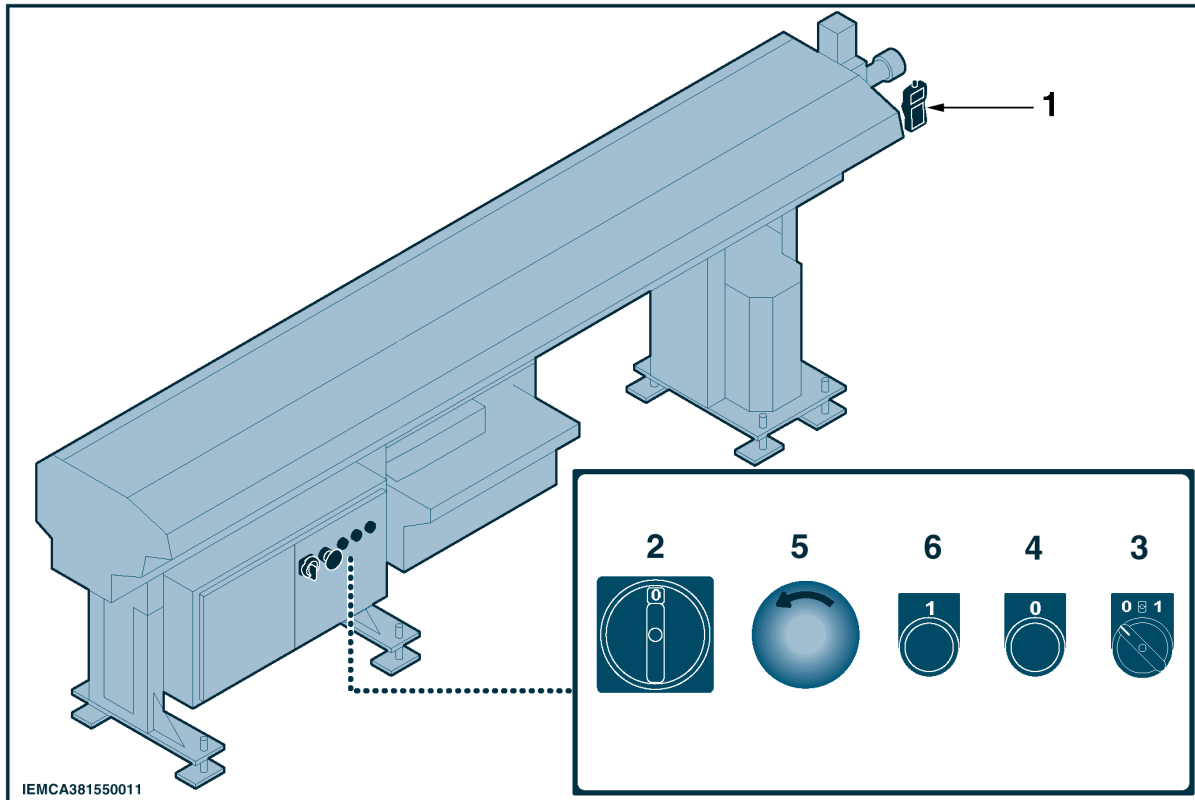

- 2 MAIN SWITCH: turns the power supply on and off.
 - Position 0 (OFF) the machine has no power supply.
 - Position I (ON) the machine has power supply.
- 3 HALF-BUSHING OPENING AND CLOSING SELECTOR (green light)
 - In "Manual" mode; if turned to 1, provided that the bar feeder is in proper working condition and the oil pump is on, the half-bushings close (the selector is lit). When turned to 0, the half-bushings open (the selector is not lit).
 - In "Automatic" mode; if turned to 1 the half-bushings close (the selector is lit) and open according to a preset sequence. If turned to 0, the half-bushings remain open during the whole working cycle (the selector is not lit).
- 4 BAR FEEDER STOP BUTTON (red): to stop the bar feeder and to reset "Errors".
- 5 EMERGENCY STOP BUTTON: this button stops the bar feeder in an emergency situation. To restart, first you must manually unlock the button
- 6 BAR FEEDER START BUTTON AND DISABLING THE BAR REMNANT DETECTION PROCEDURE (green light): to start the bar feeder, hold down the button until the button itself lights up. Holding down the pushbutton, disable the remnant and new bar controls during the bar changeover procedure.



6.2 DESCRIPTION OF KEYBOARD CONTROLS

1 Start buttons: opposite buttons that when pushed together will start some procedures. Press the two buttons, and at the same time, the key corresponding to the required function.

2 Selects the automatic mode.

3 Stops the bar feeder: to restart you must manually un-lock the button.

4 Selects the keyboard modes:

- in the  position; the "messages display" mode is selected.
- in the  position the "parameters display" mode is selected.

5 Multifunction

- Allows you to scroll the page upwards.
- Moves the cursor upwards.
- Increases the preset data programming of date and time, by one unit.

6 Selects the manual mode.

7 Selects the semi-automatic mode.

Push to select, press again to unselect.

8 Multifunction

- Selects the previous parameter.
- Moves the cursor towards the left.

9 Starts "step-by-step" movement of an operation cycle: every push of the key initiates a step in the cycle.

10 Lifts and lowers the bar selectors (LED illuminated when selectors are at their "down" position).

11 Opens/Closes the clamps (LED illuminated when clamps are open).

12 Lift and lower the pneumatic bar drop controls device (led on when this device is low).

13 Multifunction

- Allows the downwards scrolling of the page.
- Moves the cursor downwards.
- Decreases the programming mode of date and time by one unit

14 Multifunction

- Selects the next parameter
- Moves the cursor towards the right.

16 Multifunction

- Number setting.
- Moves the bar pusher to a high speed.
- Press the two running push-buttons and then the key.

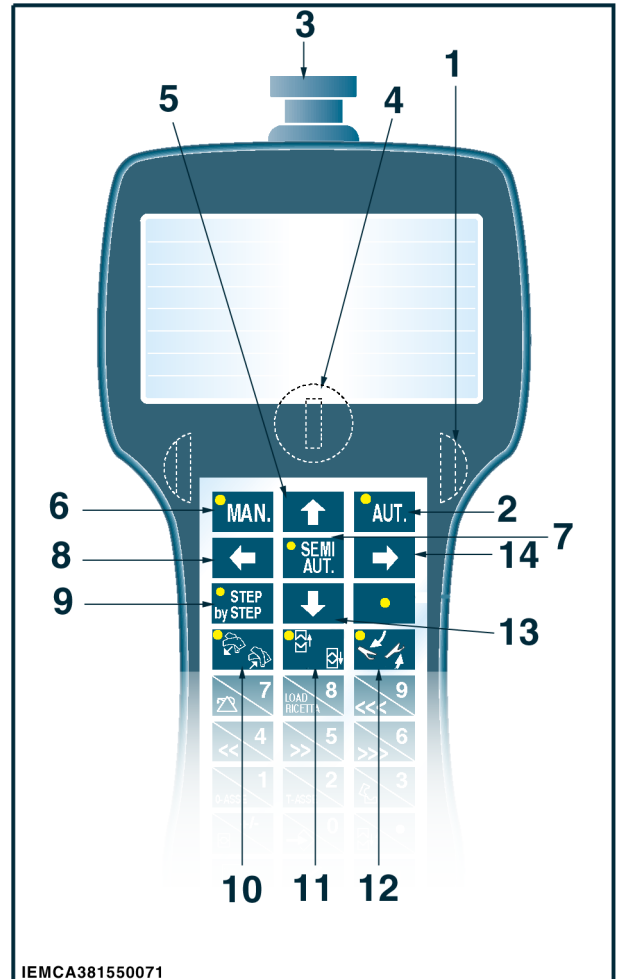

17 Multifunction

- Number setting.
- Sets the carriage movement motor.
During the daily use of the bar feeder this function must never be used.

18 Multifunction

- Number setting.
- Moves the bar pusher to a low speed.

19 Multifunction

- Number setting.
- Resets the "BAR FEEDER ZERO SETTING" of the carriage.
Hold down the two start buttons and then the * key; release the two buttons and the key when the carriage starts moving towards the "BAR FEEDER ZERO SETTING".

20 Multifunction

- Number setting.
- Closes the guide channels.
Push the two start buttons and then the * key; release the two buttons and the key only when the movement has terminated.

21 Goes to the MAIN MENU.
22 Multifunction

- Number setting.
- Recalls the cursor.

23 Multifunction

- Interrupts the selection mode.
- Resets the values held before the modifications, which were not confirmed.

24 Confirms the data entered.
26 Multifunction

- Number setting.
- Starts and turns off the oil pump (push to start and push again to turn off).

27 Multifunction

- Number setting.
- Loads the programme from the PLC (entering default settings in the parameters).

28 Multifunction key

- Sets the numerical value.
- Shifts the bar pusher at a high speed.
- Removes the bar from the bar-pusher collet.
- Press the two running push-buttons and then the key.

29 Multifunction

- Number setting.
- Opens the guide channels from the "partly open" to the "completely open" position.

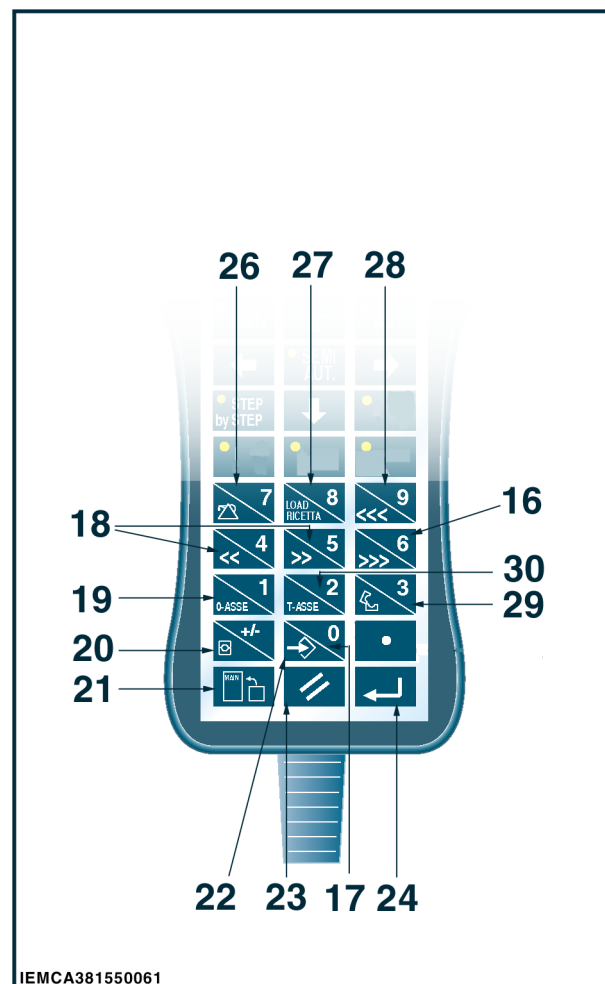

IEMCA381550061

Press  and then the key; release the two keys only when the movement is completed.

6.3 LUMINOUS INDICATOR - SIGNAL DESCRIPTION

- A RED LIGHT;
signals that the bar feeder is not operating, or that it is in the manual mode.
- B GREEN LIGHT;
it indicates that the bar feeder is in the automatic mode.
- C BLUE LIGHT;
signals that the bar feeder is carrying out the bar change.

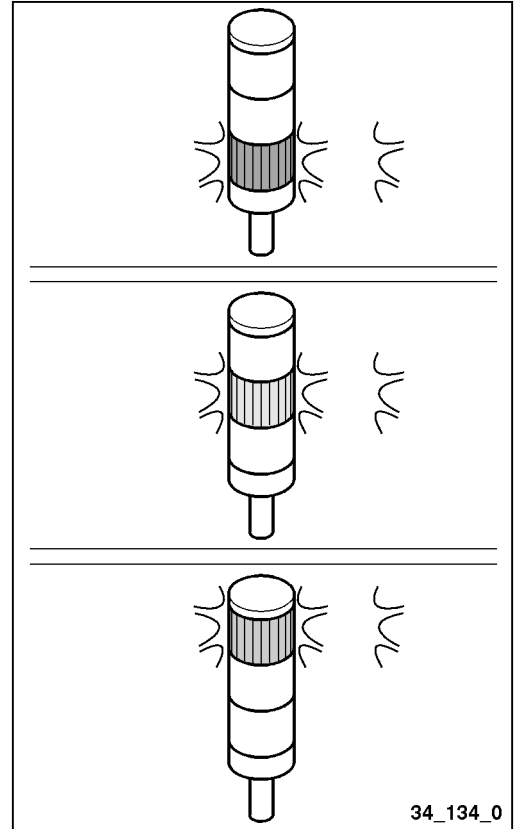

6.4 BAR FEEDER SETUP

This is a list of all the stages of the bar feeder setup, assuming that one wants to start it for the first time.

- Carry out feeder set-up according to the bar to be machined (paragraph 5.3.)
- Preparing the bars to be processed (section 6.5.).
- Load the bar magazine (paragraph 6.6.).
- Starting the automatic cycle (sections 6.7. and 6.8.).
- Adjust the lubricating oil flow (paragraph 6.9.).

6.5 BARS TO BE MACHINED - CHARACTERISTICS AND PREPARATION**CAUTION:**

do not feed bars having different sizes than the manufacturer's prescribed sizes.

Table 1. Maximum bar length

Model	Version	MAX Length mm (ft)	MIN Length mm (ft)
MASTER 880 MP Evolution	33	3300 (10,8)	1000 (3,2)
	38	3800 (12,4)	
	43	4300 (14,1)	

**INFORMATION:**

Bar must not present a straightness defect above 0.5 per 1000.

Please find herewith some advice to optimise the bar feeder performances.

Usually barstocks do not need any preliminary operations to be carried out on ends, nevertheless to obtain the best results when loading them, it is advisable to chamfer them.

SOLID BARS

Check that there is not too much rag on bar head, which might hinder insertion in the lathe collet. Check that there is not too much rag on bar rear end, which might hinder insertion in the bar-pusher collet. In any case, to improve operation during this phase, we advise to chamfer the bar as shown in the figure.

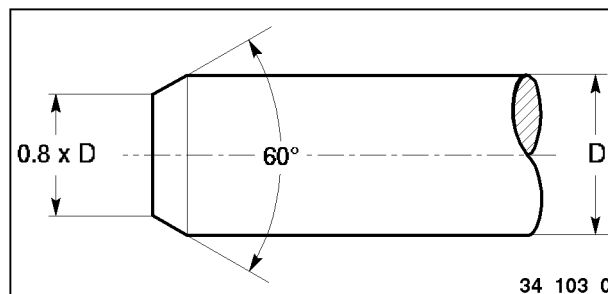

If bars with front remnant ejection have to be machined, we advise to chamfer the bar rear end as shown in the figure.

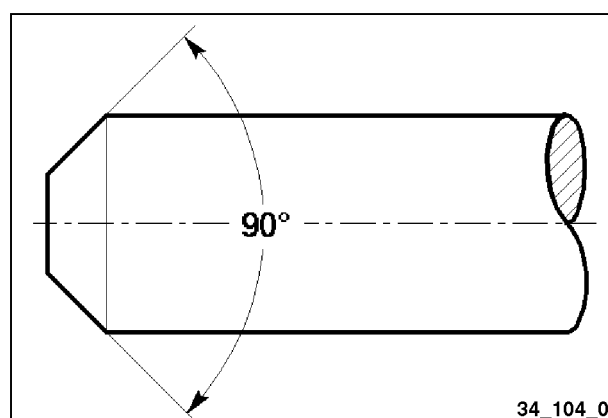

If bars have to be machined having a diameter equal to or only slightly smaller than the bar-pusher diameter, bar rear ends should be machine-turned; diameter "D" should be suitable for the collet size installed in the bar-pusher.

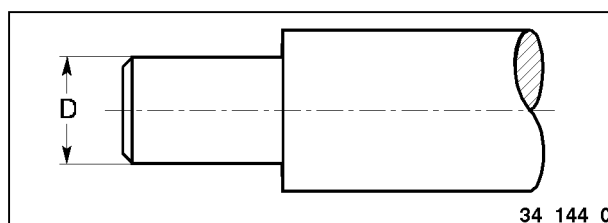
PIPES

If pipes have to be machined, their rear ends should be chamfered as shown in the figure.

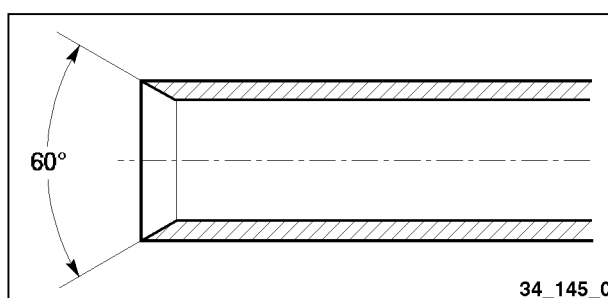

6.5.1 BAR STRAIGHTNESS - Measurement

The bar vibrations are partially caused by the condition of the bar itself: in case the bar is not perfectly straight, this can cause vibrations.

Round bars

As stated also in the UNI-10233/2 regulation, the bar straightness can be measured by positioning the bar on two V-supports and control its straightness. In that case, the measurement can be carried out as shown in the figure.

It is necessary to rotate the bar on itself and measure the three indicated sections.

In this case the S-max value (difference between maximum and minimum reading on the comparator) should be interpreted as follows:

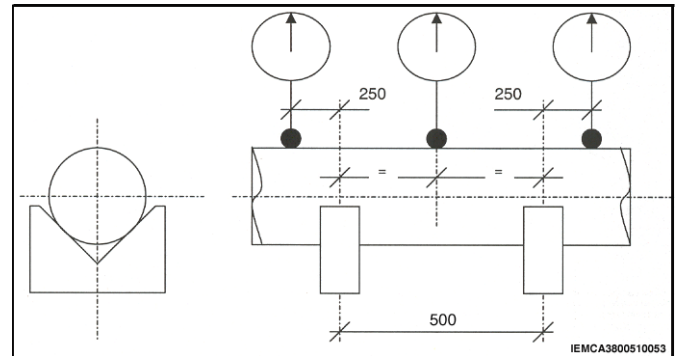

S max	Quality
< 0,25 mm	Good
0,25 < S max < 0,5 mm	Mediocre
> 0,5 mm	Problematic

In order to obtain a reliable value it is necessary to repeat measurements on the whole bar length by positioning it on a series of supports at a distance of 500 mm from each other and comparing the different values between prisms.



INFORMATION:

Obviously, bar straightness is proportional to the rigidity of the material and to the number of revolutions (RPM) the lathe is operated at. highly The lack of bar straightness highly influences the maximum number of revolutions reachable: the bigger the diameter the greater the influence. The data concerning bar straightness do not absolutely refer to local inflection and/or deformation that the bar shall not absolutely show. Instead, they refer to the bar uniform curvature.

Hexagonal, square and section bars

For non-round bars, insert some bushings on the bar to be controlled.
 Position 2 bushings on the 2 V-supports.
 In that case, the measurement can be carried out as shown in the figure.
 Rotate the bar on itself and carry out the measurement on a bushing external to the two V-supports.

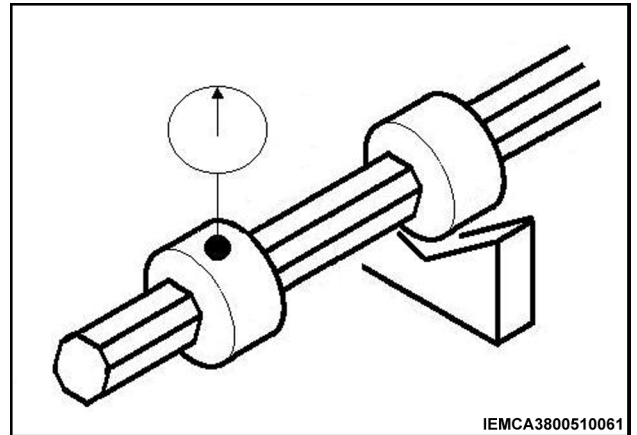

6.6 BAR MAGAZINE - LOADING



CAUTION:

do not manually lift loads heavier than those mentioned by the regulations in force; ask for an assistant's help, if needed.



CAUTION:

make use of the personal protections recommended by the regulations in force.

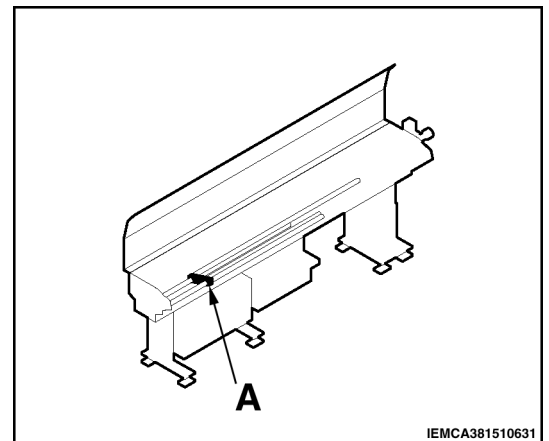

- Open the top cover.
- Position the bars against plate A and close the cover.

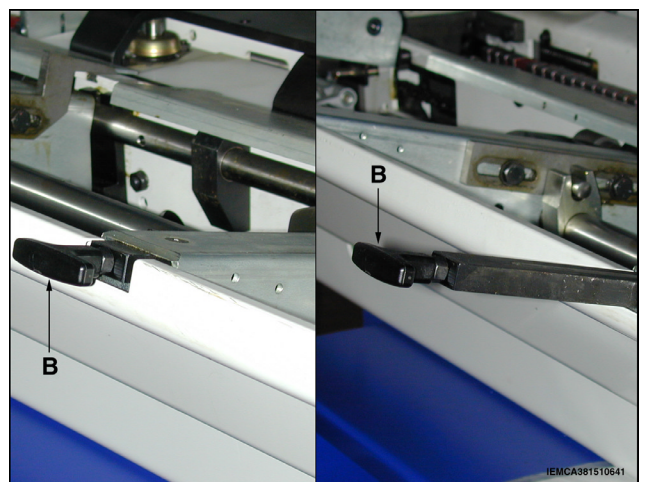

To facilitate bar loading, supports B can be extracted from the magazine.



6.7 AUTOMATIC CYCLE START

- Power the lathe on.
- Turn the main power switch to the position I (ON).



- Press  to start the bar feeder.
- Press  to select the manual mode.
- Carry out a "BAR FEEDER ZERO SETTING" in the following way:
 - press the start buttons plus ;



INFORMATION:

Axes zero setting can be performed with the guides open or closed.

- Load one bar in the guides and start the automatic cycle. (See section 6.8.).

6.8 BAR LOADING - PROCEDURE

Initial status:
 - the "AUTOMATIC signal FROM LATHE" and "OPEN COLLET" signal must be received from the lathe
 - the bar feeder must be set on its "MANUAL" function
 Press* and * to select the "SEMIAUTOMATIC" function

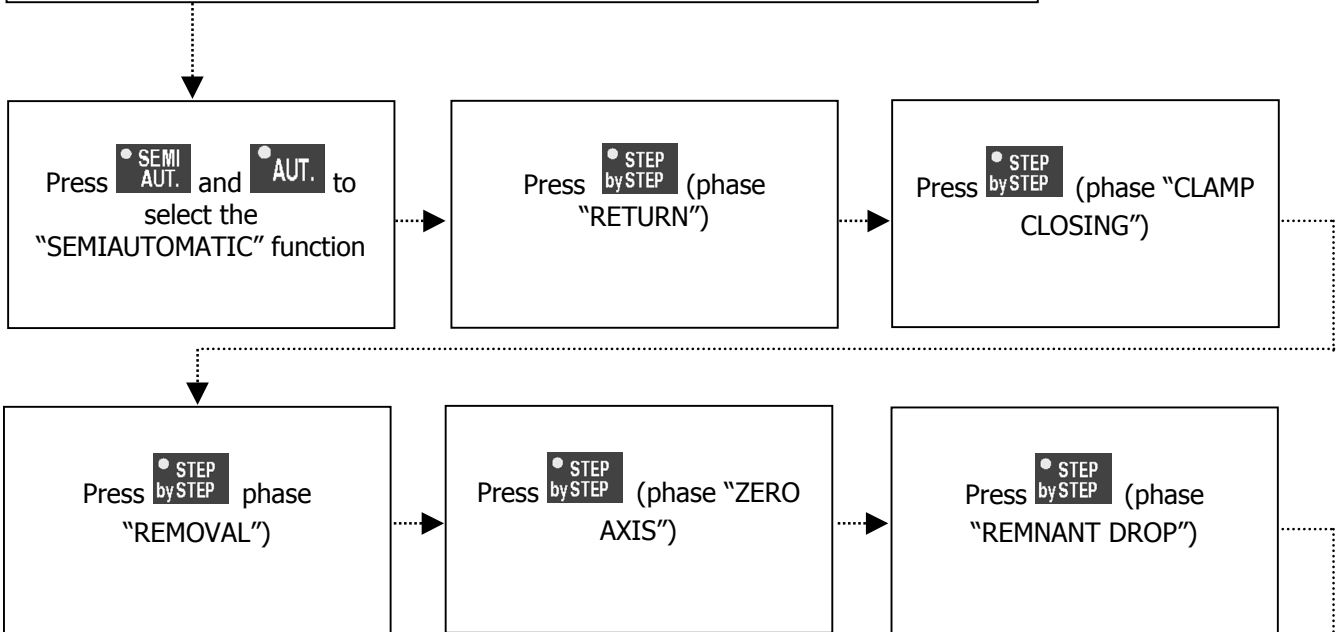

the bar drop controls will not ascend if, during the "TOTAL GUIDES OPENING" phase there was a bar in the guide channels that has prevented the short feed

Press **STEP by STEP** and hold it down until phase execution has been completed (phase "GUIDE FULL OPENING")

6.9 LUBRICATION OIL - FLOW ADJUSTMENT

Oil flow in the guides and bush-holder device is automatically controlled during the feeder automatic cycle. The pump is started after the feeder has completed bar change-over; it is stopped when the bar-pusher approaches the bush-holder device. It is necessary to adjust the oil flow in the bushing-holding device according to the bar diameter and profile.

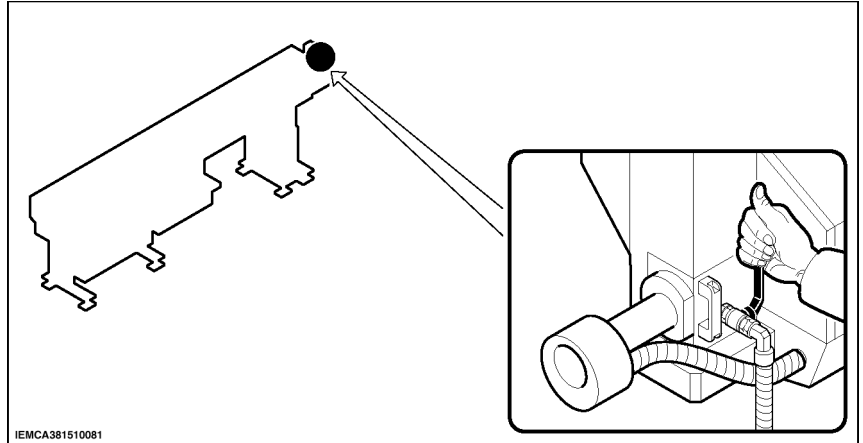

6.10 BAR FEEDER STOP

BAR FEEDER EMERGENCY STOP



CAUTION:

if the emergency stop is enabled during the lathe machining, before starting the working cycle again, make sure that no dangerous condition due to the sudden stop has occurred. Example: if the tool was removing chip, take the piece far from the lathe before starting the lathe again.

- To stop the bar feeder in the emergency status, press one of the emergency push-buttons of the bar feeder or the lathe.

BAR FEEDER STOP AT MACHINING END



CAUTION:

do not use the emergency push-buttons for the ordinary bar feeder stop.

- Achieve the operations of the working program.



- Stop the bar feeder pressing push-button .
- Stop the lathe.
- Turn the main electric switch onto position OFF.

6.11 CYCLE EXECUTION MODE IN THE "STEP-BY-STEP" FUNCTION





INTRODUCTION

This mode can be used for many reasons, as for instance:



- to check a complete bar change cycle;
- to check the bar feeder mechanics;
- eccetera.

Procedure



- Press  to start the bar feeder;
- Press  and  to select the "semiautomatic" function;
- Press,  the bar feeder performs the first step;
- Press,  the bar feeder performs the second step, and so on.

INDEX

7.1	MAINTENANCE - GENERAL RULES 2
7.2	SCHEDULED MAINTENANCE 3
7.2.1	Lubricating oil - Level check	4
7.2.2	Lubricating oil - Change.....	5
7.2.3	Air filter unit - Check	6
7.3	SCHEME OF THE LUBRICATION POINTS 7

7.1 MAINTENANCE - GENERAL RULES **DANGER - WARNING:**

carry out machine maintenance and cleaning while the machine is off.

Regular cleaning and maintenance are critical to ensure smooth operation and longer machine service life.

It is recommended to regularly and effectively clean the machine, its accessories and work area, which also increases operator's safety.

Do not use petrol or solvents which would damage the painted and transparent parts, the cable sheaths etc.

**INFORMATION:**

oxidation can damage metal parts and electric equipment.

To protect the bar feeder during long periods of inactivity, disconnect it from the mains, let the compressed air out and cover with a piece of adequate cloth.

Any protection used should not be fully closed or sealed at the base; it should have ventilation holes to make sure that air within the envelope cannot condense due to lack of circulation.

7.2 SCHEDULED MAINTENANCE 

Table 1. Scheduled maintenance

Model	Bar feeder part	Operation to carry out	Frequency					
			Hours				Every year	Periodically
			200	500	1250	2500		
MASTER 880 MP Evolution	Revolving tip and collet	Wear check	•					
	Half-bushing	Wear check	•					
	Lubrication system	Oil level check	•					
		Oil change				•		
	Guides	Repair and cleanness check			•			
	Guide opening screw	Greasing			•			
	Feed chain	Lubrication	•					
		Tension check			•			
	Guide opening belt	Wear check				•		
	Air filter	Check						•
	Keyboard battery	Replacement					•	
	PLC Battery	Replacement					•	

7.2.1 Lubricating oil - Level check**CAUTION:**

wear the personal protections prescribed by the applicable standards in force.

- Wait until the bar feeder has been off for at least 6 hours.
- Check the level through the indicator A.
- Pour the oil directly in the tank to fill up, if needed.

Oil characteristics: C CLASS -
CKB 150.

See paragraph 2.6. for the comparative table.

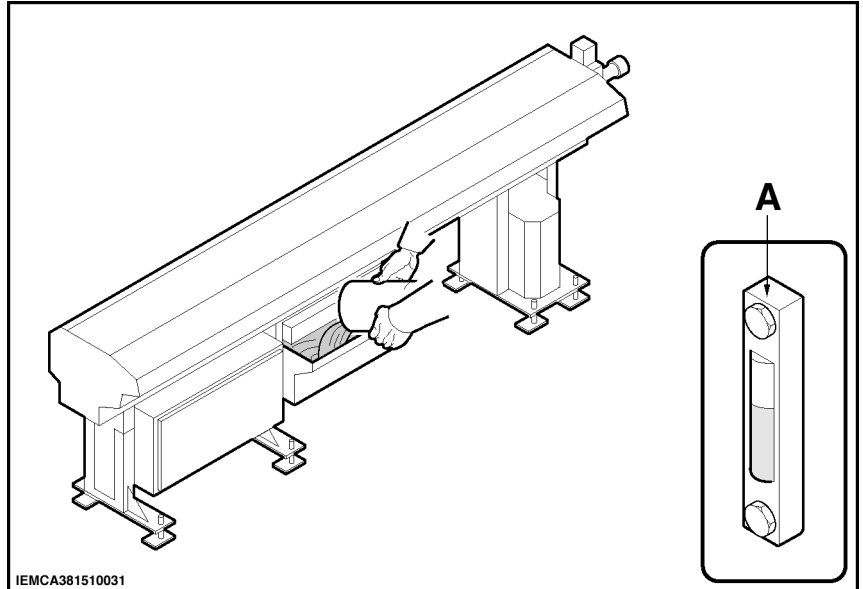

7.2.2 Lubricating oil - Change



CAUTION:

wear the personal protections prescribed by the applicable standards in force.



INFORMATION:

store spent oil in special containers to be delivered to companies specialized in pollutant disposal and storage.

- Remove the cover (A) and grid (B).
- Empty the tank with the use of an auxiliary pump, or through the draining plug (C). Clean the tank bottom and pump suction system.
- To load, pour the oil directly in the tank and check the level through the indicator (D).

Oil characteristics: C CLASS - CKB 150, amount 80 l.

See paragraph 2.6. for the comparative table.

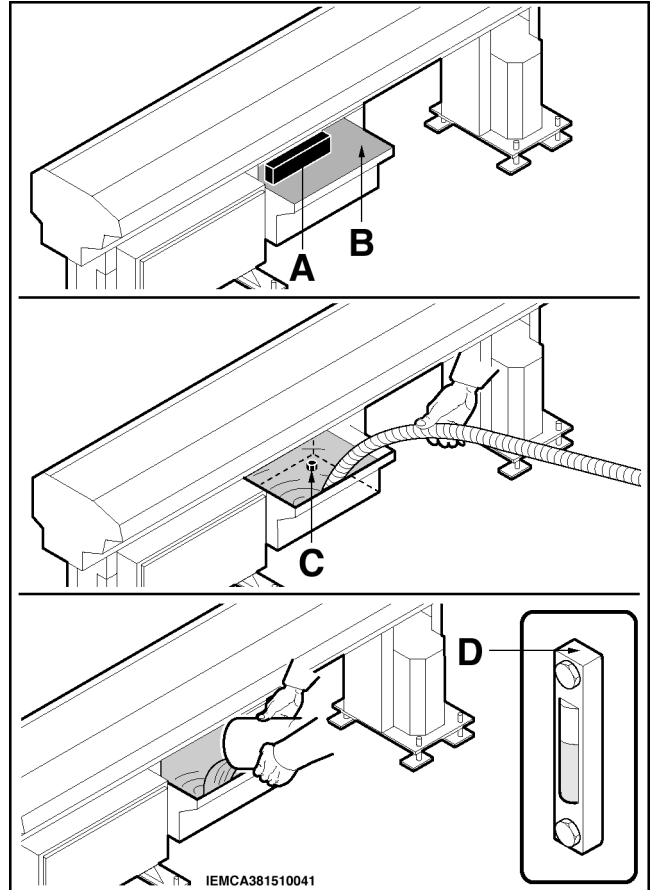

7.2.3 Air filter unit - Check

FILTER (A)

- Make sure that cup (B) is not full of condensate. If need be, bleed the condensate by valve (C). Make sure that cup (B) is not full of condensate. If need be, bleed the condensate by valve (C).
- The filter is equipped with a control pressure switch, set to a pressure of 4.5 bar.
 - remove the pressure gauge protecting glass;
 - turn the adjusting screw (G) anticlockwise (+) to increase pressure or clockwise (-) to lower it;
 - after this operation, replace the pressure gauge protecting glass.

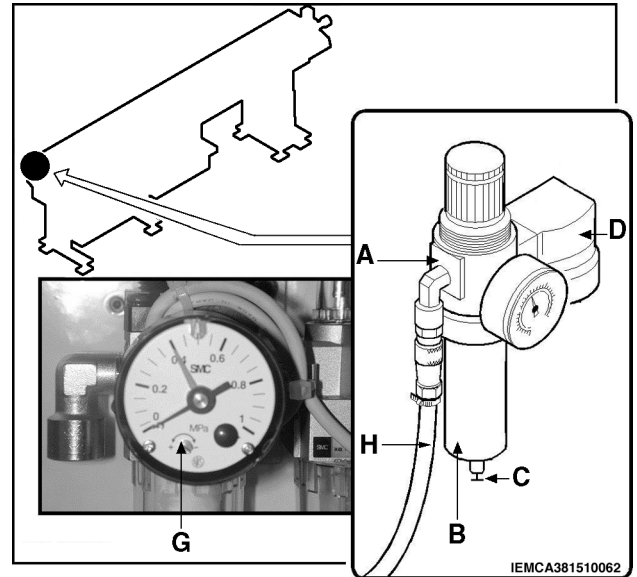

CAUTION:

should the pressure switch needle point a Pressure=0 , do not absolutely turn the adjusting screw (H) clockwise (-) , for this will cause pressure switch breakage.

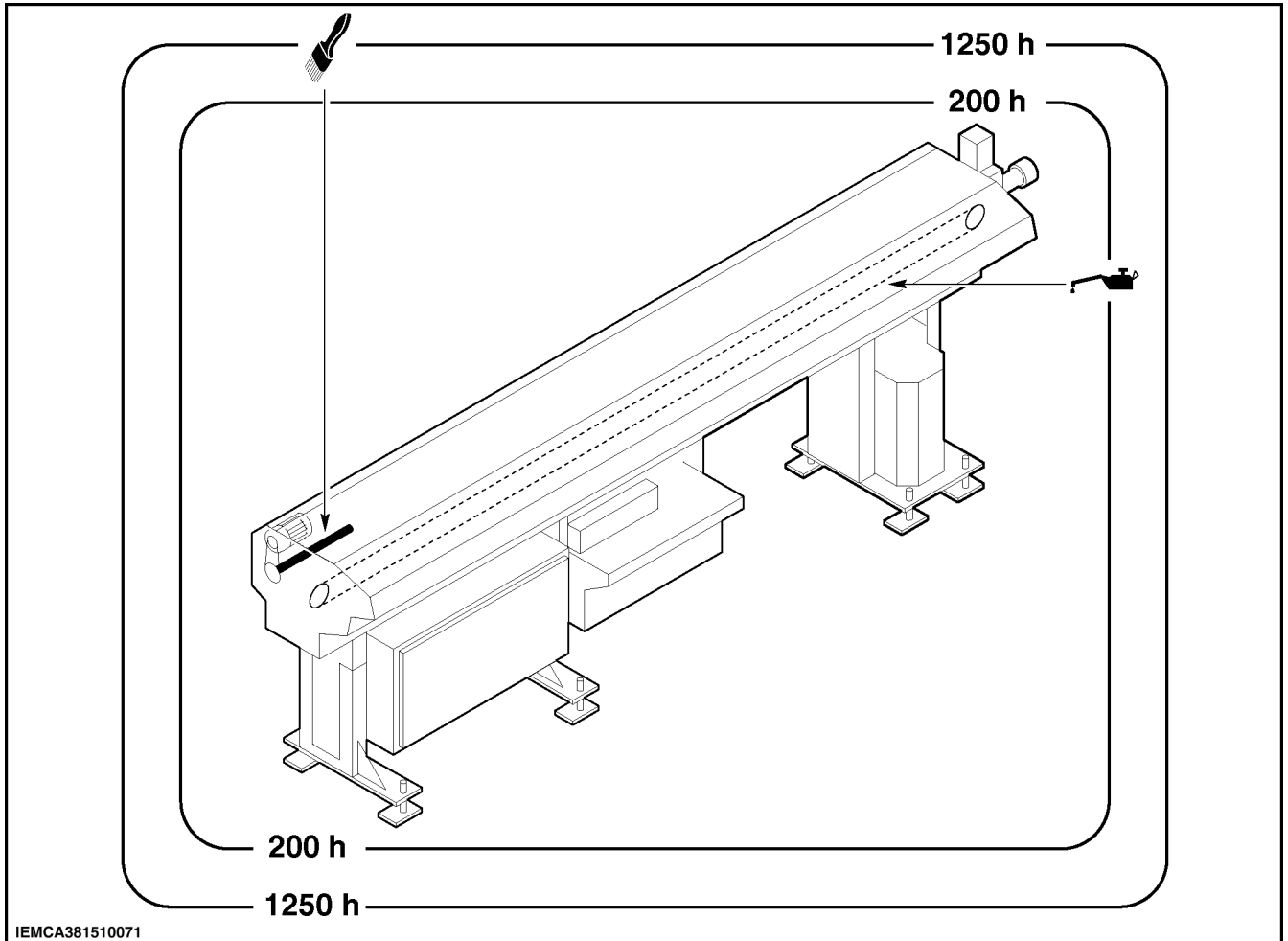

7.3 SCHEME OF THE LUBRICATION POINTS 

Engrasar



Aceitar

INDEX

8.1	GENERAL FAULTS 2
8.2	INSERTION IN THE COLLET - Faults 2
8.3	BAR FEEDING - Faults 2

8.1 GENERAL FAULTS 

TROUBLE	CAUSES	CURES
The bar feeder will not start	No power	Check the electric connections
	Open guard	Close the guard
	Emergency systems on	Disconnect the emergency devices
	Motor thermal switch tripped	Reset the motor overload cut-out with the special push-buttons.
The bar feeder has been reset but the automatic cycle will not start	No lathe signal	Check electric connection to the lathe
The pneumatic devices will not respond to controls	No air	Check the air system
The pre-feed and feed suddenly stop	Motor thermal switch tripped	Reset the motor overload cut-out with the special push-buttons





8.2 INSERTION IN THE COLLET - Faults 

PROBLEMS	CAUSES	CORRECTIVE ACTION
Bar fails to enter collet.	Collet diameter not suitable for bar diameter.	Change collet.
	Excessive rag on bar rear end.	Trim rag before feeding.

8.3 BAR FEEDING - Faults 

PROBLEMS	CAUSES	CORRECTIVE ACTION
Difficult bar introduction into lathe spindle	Bar feeder not aligned with lathe.	Check and correct alignment.
Difficult bar introduction into lathe collet	Excessive rag on bar rear end.	Trim rag before feeding.

INDEX

9.1	FEED CHAIN - REPLACEMENT 2
9.2	GUIDE CHANNELS OPENING BELT - Replacement.....	2
9.3	PLC BATTERY - REPLACEMENT 3
9.4	KEYBOARD BATTERY - REPLACEMENT 4
9.5	RECOMMENDED SPARE PARTS 5

9.1 FEED CHAIN - REPLACEMENT

Replacement of the feed chain is a highly complex operation; call IEMCA after-sales service.

9.2 GUIDE CHANNELS OPENING BELT - Replacement

- Manually turn the pulley A and simultaneously pull the belt all the way out.
- Place a new belt in the pulley B, lead it into the pulley A and turn the belt until it is fully inserted.

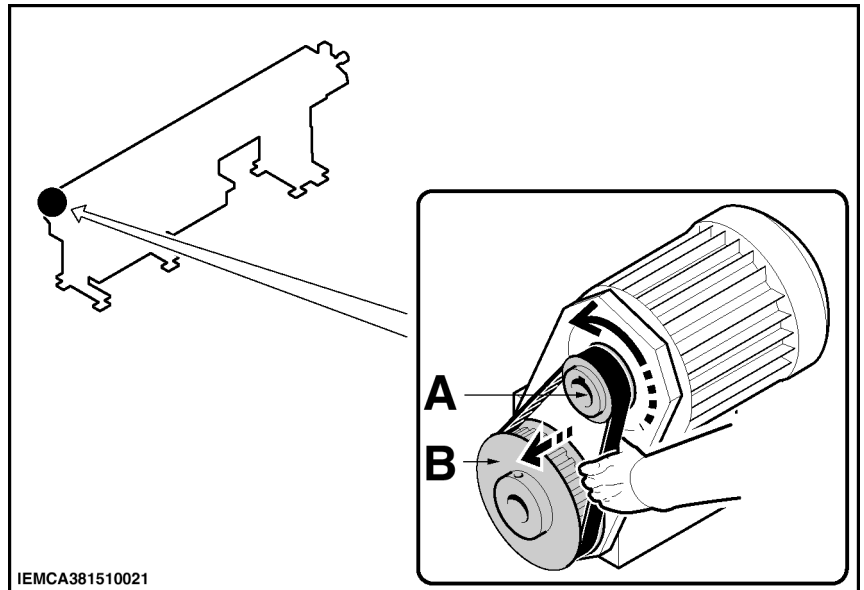

9.3 PLC BATTERY - REPLACEMENT

Replace the battery at least every year, and when the following message is displayed: "PLC battery exhausted"



INFORMATION:

when this message is displayed, the battery should be replaced within one day, otherwise, the "PLC/NC Software" data will be deleted.

- Unscrew cap (A) and pull out battery (B);
- insert a new battery (AA 3.6volts lithium-type battery) and make sure that it is introduced correctly, then tighten the cap (A).

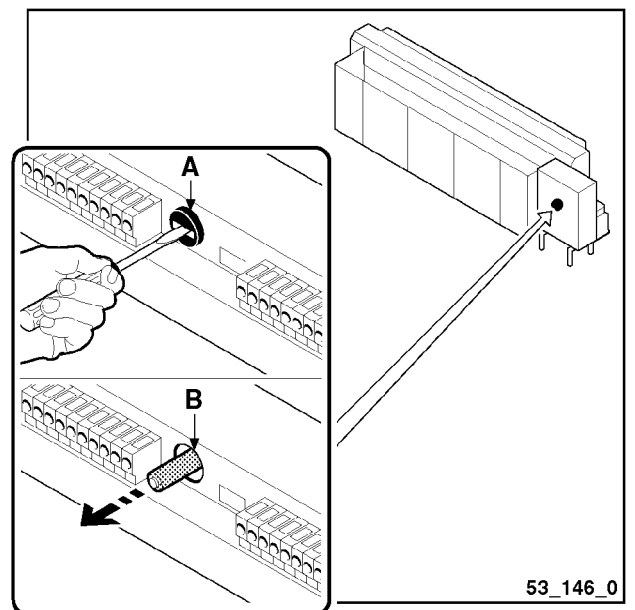

9.4 KEYBOARD BATTERY - REPLACEMENT

Replace the battery at least every year, and when the following message is displayed "KEYBOARD BATTERY EXHAUSTED":



INFORMATION:

failure to replace the battery can cause the calendar - clock memory to be deleted.



- Disconnect power.
- Screw out the six screws and remove the two half-shells.

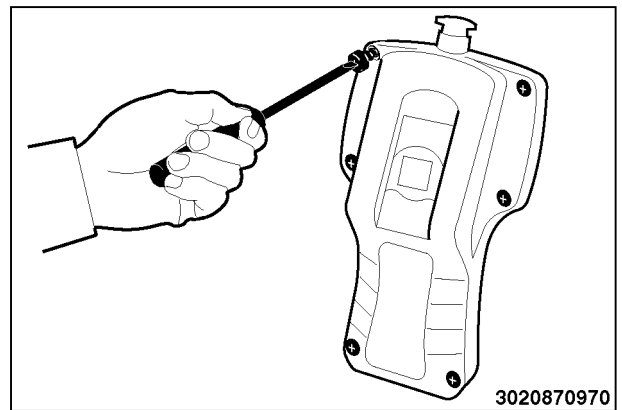

- Remove the battery A from its housing.
- Insert a new battery (type DURACELL DL2430).



DANGER - WARNING:

danger of battery explosion if the battery is mounted with inverted poles.

- Put the two half-shells back in place and screw down the six screws.
- Connect electric power again.

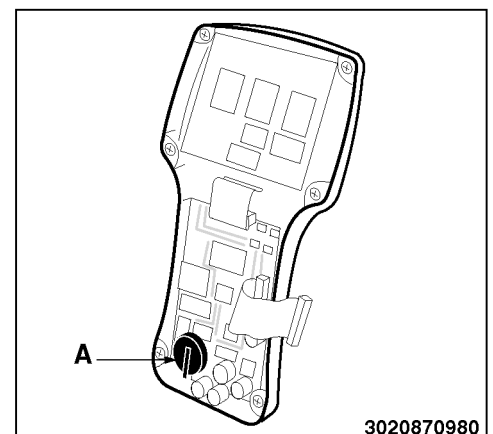

INFORMATION:

Discard spent batteries by depositing them at authorised collection points. Help protect the environment.

9.5 RECOMMENDED SPARE PARTS

The heavy-wear parts or easily broken parts are listed below (this list refers to bar feeder requirements for a two year's period of normal use).

Model	Name	Notes	Quantity
MASTER 880 MP Evolution	Feed chain	For model 33	1
	Feed chain	For model 38	1
	Feed chain	For model 43	1
	Connection link		1
	Sensors		/
	Bar-pusher	Specify diameter and length	1
	Revolving tip	Specify diameter	1
	Collet	Specify inside and outside diameter	1

To order the parts refer to the Spare Parts Catalogue.

LIST OF AFTER-SALES CENTERS

ENGLAND:	CSJ Enterprises	Unit 96 Springhill Farm Salters Lane, Lower Moor Nr. Persnore, Worcs WR10 2PE	Tel. +44 01386 861777 Fax +44 01386 861666 Email: CSJENT@AOL.com
FRANCE:	IEMCA France	Z.I. Des Grands Pres 145, rue Louis Armand 74300 Cluses	Tel +33 450 896960 Telefax +33 450 896135 Email: iemca@iemca.fr
GERMANY: <i>(West - Nord- Deutschl.)</i>	Hoßfeld GmbH	Königsberger Straße 10 D-58511 Lüdenscheid	Tel. ++49 02351 / 80521 Fax ++49 02351 / 860442 Email: HossfeldgmbH@t-online.de
GERMANY: <i>(Neue Länder)</i>	Heyde Maschinen Service	Albin-Trommler-Str. 3 D-08297 Zwönitz	Tel. ++49 037754 / 5090 Telefax ++49 037754 / 50920 Email: Heyde-maschinen- service@t-online.de Heyde-zwoenitz@t-online.de
GERMANY: <i>(Süd-Deutschl)</i>	Reimo Lobers	Elektro-Mechanischer Betrieb Rebgartenweg 5/1 D-79576 Weil am Rhein	Tel. ++49 07621 / 69551 Fax ++49 07621 / 69491 Email: Mail@lobers.de
ITALY:	IEMCA S.p.A.	Via Granarolo, 167 I-48018 Faenza (RA)	Tel. 0546 / 698208 Fax 0546 / 698290 Email: iemca@igmi.it
SWITZERLAND: <i>(Canton ticino)</i>	IEMCA S.p.A.	Via Granarolo, 167 I-48018 Faenza (RA)	Tel. 0546 / 698208 Telefax 0546 / 698290 Email: iemca@igmi.it
SWITZERLAND: <i>(Deutschl. Switzerland)</i>	FRITZ NIEDERHAUSER HANDEL & SERVICE AG	Bahnhofstrasse 18 CH-6048 Horw	Tel. ++41 041 / 3405075 Telefax ++41 041 / 3405074 Email: info@niederhauser.ch
SWITZERLAND: <i>(Switzerland Français)</i>	BARSPPEED	Zone industrielle CH- 2607 Cortébert	Tel. ++41 032 / 4892726 Telefax ++41 032 / 4892729
TAIWAN:	GIMCO	No9, 19 th Road Taichung Industrial Park - Taichung - Taiwan R.O.C	Tel. ++886-4-359-6980 Telefax ++886-4-358-6838 Email: gimco@gimco.com.tw
JAPAN:	IGM Nippon K.K.	321-1-967, Kashiwagaya, Ebina-shi, Kanagawa Zip code 243-0402	Tel ++81 462 36 3613 Telefax ++81 462 36 3614 E-mail: hitoshi-j- bigl@msg.biglobe.ne.jp
U.S.A. CANADA :	HYDROMAT INC.	11600 Adie Road St. Louis, MO 63043	Tel. ++314 6928388 Telefax ++314 6925152 Email: iemcaservice@hydromat.com

GUIDE CHANNELS
GUIDE-BARRES
BAR PUSHER
POUSSETTE
REVOLVING TIPS
EMBOUTS TOURNANTS

MASTER 880 P/F

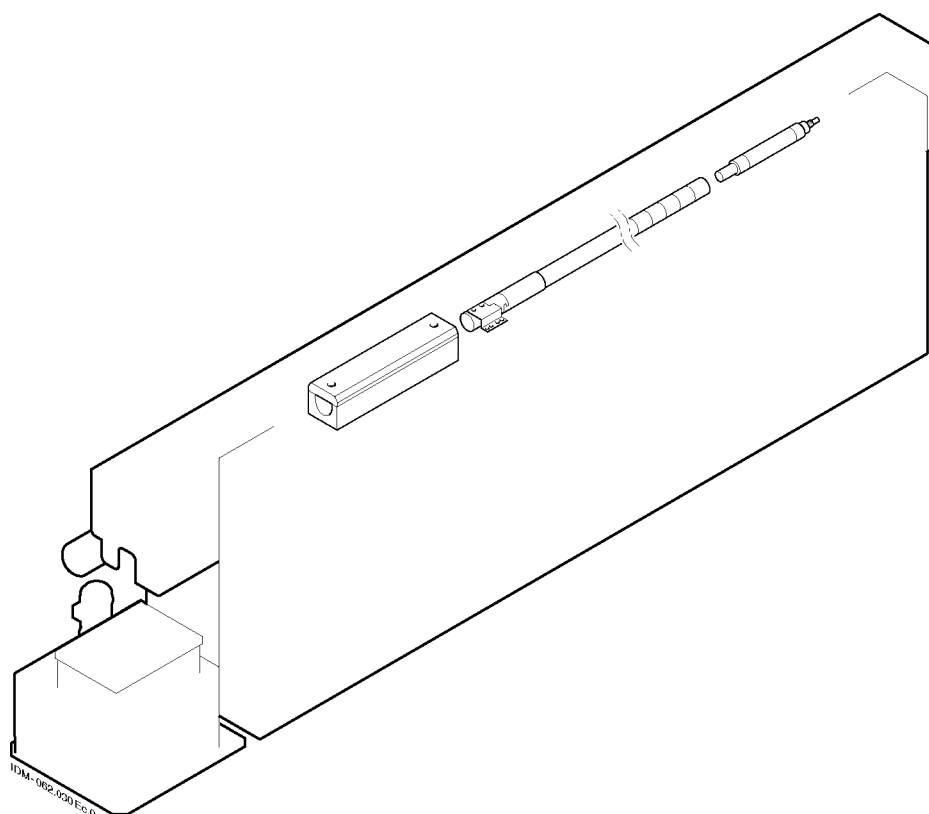

Read this introductory section carefully; it will help you easily trace the data you require. This manual is divided into a number of parts which are in turn divided into a number of sections (see contents page). These contain detailed information relative to the equipping of the bar feeders depending on the cross-section of the barstock, its diameter, the type of collet to be used, etc.

An example of the method of consultation described below refers to equipping of a BOSS 542 model bar feeder; the procedure described may vary for other bar feeder models.

Nous recommandons de lire attentivement cette partie introductive ; vous pourrez ainsi retrouver plus facilement les données qui vous intéressent. Ce manuel est composé de plusieurs fascicules subdivisés en différentes sections (voir index). Il contient une série d'informations articulées, relatives au montage des chargeurs en fonction de la barre à usiner, de son diamètre, du type de pinces à utiliser, etc.

L'exemple de consultation ci-dessous concerne le montage du chargeur modèle BOSS 542; la procédure qui y est décrite peut subir des variations selon les modèles de chargeurs.

A Select and consult the specific section concerning the bar feeder you are interested in.

A Sélectionner et consulter le fascicule correspondant au modèle du chargeur qui vous intéresse.

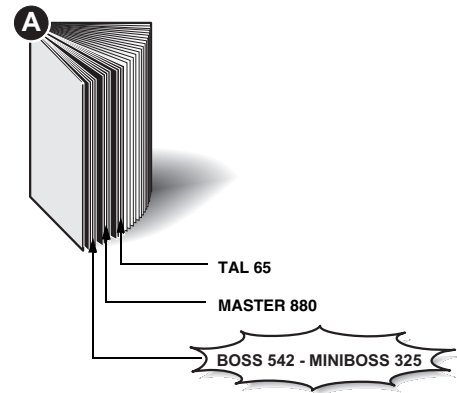

B Consult the "GUIDE CHANNELS AND BAR PUSHER - Table" section of the selected section, select the guide channels and bar pushers suitable for the diameter of the barstock. While ordering these, specify the code, which is to be found in the "Spare parts catalogue".

B Consulter la section "GUIDE-BARRES ET POUSETTE - Tableau" du fascicule sélectionné, choisir les guide-barres et la poussette en fonction du diamètre de la barre à usiner. Pour toute commande, spécifier le code, indiqué dans le "Catalogue des pièces détachées".

B

BOSS 542 - BOSS 542 r

Bar diameter - eA (mm) Diamètre barre - eA (mm)		eA (mm) Maximum sub-diameter (-) Diamètre maximum des tubes (-)	eB (mm) Guide bar diameter Diamètre des guide-barres	eC (mm) Bar pusher diameter Diamètre de la poussette
Min	Max			
5	13	15	17	15

C Consult the "REVOLVING TIP - Table" section to select the revolving tip according to the diameter of the guide channel and that of the bar pusher, and the collet model to be used⁽¹⁾.

C Consulter la section "EMBOUOT TOURNANT - Tableau" pour choisir l'embout tournant en fonction du diamètre des guide-barres, de celui de la poussette et de la version pince à utiliser⁽¹⁾.

BOSS 542 - MINIBOSS 325 002

REVOLVING TIP - Table **EMBOUOT TOURNANT - Tableau**

eB (mm) Guide channel diameter Diamètre des guide-barres	eC (mm) Bar pusher diameter Diamètre de la poussette	Collet version - D (see previous Version pince - D (voir précédent)	eGR (mm) Revolving tip diameter Diamètre embout tournant	Revolving tip code Code embout tournant	See section Voir section BOSS 542- MINIBOSS 325
10	10	Threaded (IEMCA) Fileté (IEMCA)	10	D71151000	003
13	12	Weldon (SCHL) Axe goupille	12	D71151201	004
17	15	Threaded (IEMCA) Fileté (IEMCA)	15	D71151500	003
16	16	Weldon (SCHL) Axe goupille	16	D71151601	004

D Consult the "REVOLVING TIP øGR 10÷27 - Table" section to select the type of collet⁽²⁾.

This section contains the dimensions of the revolving tip and a series of drawings of collets, with reference to the corresponding sections in which you will find the code number of the collet to be used.

D Consulter la section "EMBOUOTS TOURNANTS øGR 10÷27 - Tableau" pour choisir le type de pince⁽²⁾.

Cette section présente un tableau des dimensions de l'embout tournant et une série d'illustrations des pinces accompagnée des références aux différents fascicules dans lesquels retrouver le code de la pince à utiliser.

BOSS 542 - MINIBOSS 325 003

REVOLVING TIPS øGR 10÷27 **EMBOUOTS TOURNANTS øGR 10÷27**

Table **Tableau**

eGR (mm)	Revolving tip code Code embout tournant	aF (mm)	eB (mm)	GP (mm)	G1 (mm)	C (mm)	A1 (mm)	aSP (mm)	P (mm)
10	D71151000	M8x1	10.5	160	30	8	6	3	24.5
15	D71151500	M8x1	15.5	160	35	12	6	3	26.5
18	D71151800	M8x1	18.5	160	35	12	6	4	28.5
19	D71151900	M8x1	19.5	160	35	12	6	4	28.5
20	D71152000	M10x1	20.5	172.5	35	14	6	4	38.5
23	D71152300	M10x1	23.5	172.5	35	14	6	4	38.5
25	D71152500	M10x1	25.5	172.5	35	17	6	5	38.5
27	D71152700	M10x1	27.5	172.5	35	17	6	5	38.5

(1) Collet model; identifies the type of collet-revolving tip coupling (e.g. threaded coupling, pin coupling, etc.).

Version pince; indique le type d'accouplement (par ex. accouplement fileté, avec goupille, etc.).

(2) Type of collet; identifies the cross-section of the barstock and the type of machining.

Type de pince; indique la section de la barre à usiner et le type d'usinage à adopter.

E Consult the "001 - Conversion Tables" section which contains the conversion tables for defining the internal diameter of the collet depending on the:

- profile and cross-section of the barstock
- the unit of measurement of the section dimensions (in millimetres for square and hexagonal sections, and in inches for round and hexagonal sections).

E Consulter le fascicule "001 - Tableaux de conversion" contenant les tableaux de conversion pour établir le diamètre interne de la pince en fonction:

- du profil et de la section de la barre à usiner
- de l'unité de mesure de la dimension de la section (en millimètres pour les sections carrées et hexagonales et en pouces pour les sections rondes et hexagonales).

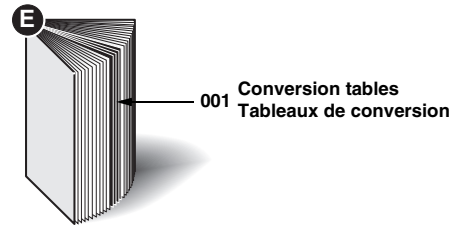

CONVERSION TABLES 001 **TABLEAUX DE CONVERSION 001**

HEXAGONAL BARS (unit of measurement "millimetres") - Table **BARRES HEXAGONALES (unité de mesure "millimètres") - Tableau**

Before selecting the steel collet, define the internal diameter ϕA by consulting the table below. Avant de procéder au choix de la pince en acier, il est nécessaire d'établir son diamètre interne ϕA , après consultation du tableau suivant.

ϕZ	Y	ϕA	ϕZ	Y	ϕA
mm	mm	mm	mm	mm	mm
3.5	4.04	3.8	30	34.64	34.5
4	4.61	4.5	31	35.79	35.5
4.5	5.18	5	32	36.95	36.5
5	5.77	5.5	33	38.10	37.5
5.5	6.35	6.2	34	39.25	38
6	6.92	6.8	35	40.41	40.2
6.5	7.50	7.3	36	41.56	41.5
7	8.08	7.8	38	43.87	43.5
8	8.66	8.2	39	45.02	44.5
9	9.24	8.7	40	46.18	46
10	9.82	9.2	42	47.34	47
11	10.40	9.7	43	48.49	48.2
12	10.99	10.2	44	49.65	49.5
13	11.58	10.8	45	50.80	50.5
14	12.17	11.4	46	51.96	51.8
15	12.76	12.0	48	53.11	52.8
16	13.35	12.6	49	54.27	53.8
17	13.94	13.2	50	55.42	54.8
18	14.53	13.8	52	56.57	55.8
19	15.12	14.4	53	57.73	56.8
20	15.71	15.0	54	58.88	57.8
21	16.30	15.6	55	60.04	58.8
22	16.89	16.2	56	61.20	59.8
23	17.48	16.8	57	62.35	60.8
24	18.07	17.4	58	63.51	61.8
25	18.66	18.0	59	64.67	62.8
26	19.25	18.6	60	65.82	63.8
27	19.84	19.2	62	66.98	64.8
28	20.43	19.8	64	68.13	65.8
29	21.02	20.4	65	69.29	66.8
30	21.61	21.0	66	70.44	67.8
31	22.20	21.6	67	71.60	68.8
32	22.79	22.2	68	72.75	69.8
33	23.38	22.8	69	73.91	70.8
34	23.97	23.4	70	75.06	71.8
35	24.56	24.0	72	76.22	72.8
36	25.15	24.6	73	77.37	73.8
37	25.74	25.2	74	78.52	74.8
38	26.33	25.8	75	79.68	75.8
39	26.92	26.4	76	80.83	76.8
40	27.51	27.0	77	81.98	77.8
41	28.10	27.6	78	83.14	78.8
42	28.69	28.2	79	84.29	79.8
43	29.28	28.8	80	85.44	80.8
44	29.87	29.4	81	86.59	81.8
45	30.46	30.0	82	87.75	82.8
46	31.05	30.6	83	88.90	83.8
47	31.64	31.2	84	90.05	84.8
48	32.23	31.8	85	91.20	85.8
49	32.82	32.4	86	92.36	86.8
50	33.41	33.0	87	93.51	87.8
51	34.00	33.6	88	94.66	88.8
52	34.59	34.2	89	95.81	89.8
53	35.18	34.8	90	96.96	90.8
54	35.77	35.4	91	98.11	91.8
55	36.36	36.0	92	99.26	92.8
56	36.95	36.6	93	100.41	93.8
57	37.54	37.2	94	101.56	94.8
58	38.13	37.8	95	102.71	95.8
59	38.72	38.4	96	103.86	96.8
60	39.31	39.0	97	105.01	97.8
61	39.90	39.6	98	106.16	98.8
62	40.49	40.2	99	107.31	99.8
63	41.08	40.8	100	108.46	100.8

F Consult the "011 - Bar collets" section to identify the code number of the collet selected.

For identifying this code, use the data obtained from previous consultations.

For example:

- coupling diameter with revolving tip
- internal diameter of collet corresponding to diameter of the round section bar (in millimetres); for profiles of bars which do not have these characteristics, consult the references found in the "001 - Conversion Tables" section.

F Consulter le fascicule "011 - Pincés barres" pour identifier le code de la pince sélectionnée.

Pour l'identification de ce code, utiliser les données déjà obtenues au cours des consultations précédentes.

Par exemple :

- diamètre d'accouplement avec l'embout tournant
- diamètre interne de la pince correspondant au diamètre de la barre avec section ronde (en millimètres); pour les profils de barres ne présentant pas les mêmes caractéristiques, consulter les références indiquées précédemment dans le fascicule "001 - Tableaux de conversion".

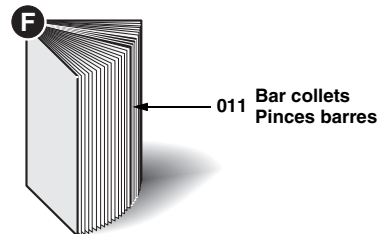

IEMCA **011**

ϕA	ϕF M12x1	ϕF M3x1	ϕF M3x1	ϕF M3x1	ϕF M12x1	ϕF M12x1
mm	in	ϕD 15	ϕD 16	ϕD 18	ϕD 20	ϕD 23
9.5		01120950	01115990		01120950	
9.6	3/8"	01120960	01115990		01120960	
9.7		01120970	01115970			
9.8		01120980	01115980		01120980	
9.9		01120990	01115990			
10	25/64"	01121000	01115100		01121000	
		01121010				
		01121020	011151020		01121020	
		01121030			01121030	
10.2	13/32"	01121040	011151040		01121040	
10.5		01121050	011151050		01121050	
10.8		01121060	011151060		01121060	
10.7		01121070	011151070		01121070	
10.8	27/64"	01121080	011151080		01121080	
10.9		01121090	011151090			
11		01121100	011151100		01121100	
11.25	7/16"	011151120	011151120	011151120	011201120	
11.5		011151160	011151160	011151160	011201160	
11.75	13/64"	011151170	011151170	011151170	011201170	
12		011151200	011151200	011151200	011201200	
12.25		011151220	011151220	011151220	011201220	
12.5	31/64"	011151250	011151250	011151250	011181250	011201250
12.75	1/2"	011151270	011151270	011151270	011181270	011201270
13		011151300	011151300	011151300	011181300	011201300
13.25		011151320	011151320	011151320	011181320	011201320
13.5		011151350	011151350	011151350	011181350	011201350
13.75		011151370	011151370	011151370	011181370	011201370
14		011151400	011151400	011151400	011181400	011201400
14.25	9/16"	011151420	011151420	011151420	011181420	011201420
14.5			011151450	011151450	011181450	011201450
14.75				011151470	011181470	011201470
15					011181500	011201500
15.25					011181520	011201520

☐ Symbols

Parts of the text which are of considerable importance are highlighted in bold and are preceded by the following symbols:



CAUTION: indicates that it is necessary to adopt suitable measures for preventing accidents and damage to objects.



INFORMATION: these are technical instructions of considerable importance.

The symbols used in the tables and figures are as follows:

- bars with round section
- bars with square section
- ◆ bars with hexagonal section
- bars with tubular section

☐ Abbreviations

CH key socket
GR revolving tip
SP hole for pin

The abbreviations in the drawings, which are easy to interpret, are not included in this list.

☐ Symboles

Les parties les plus importantes du texte sont mises en relief en caractères gras et sont précédées des symboles :



PRECAUTION: indique qu'il s'avère nécessaire d'adopter les comportements adéquats afin d'éviter accidents et dommages.



AVERTISSEMENT: il s'agit d'indications techniques particulièrement importantes.

Dans les tableaux et figures, les symboles suivants peuvent apparaître:

- barre à section ronde
- barre à section carrée
- ◆ barre à section hexagonale
- barre à section tubulaire

☐ Abréviations

CH prise de clé
GR embout tournant
SP orifice pour goupille

Les abréviations faciles à interprétées reportées dans les illustrations, ne font pas partie de cette liste.

GUIDE CHANNELS AND BAR PUSHER - Table

The choice of guide channels and bar pusher depends on the diameter of the barstock. The bar feeder is usually supplied with a bar pusher whose diameter is equal to the maximum bar passage of the lathe. In certain cases, in order to work in the best possible conditions, it may also be necessary to use a bar pusher with smaller diameter.

GUIDE-BARRES ET POUSSETTE – Tableau

Le choix des guide-barres et de la poussette doit être fait en fonction du diamètre de la barre à usiner. Le chargeur est en principe fourni avec une poussette d'un diamètre équivalent au passage maximum de la barre du tour. Dans certains cas, pour de meilleures conditions de travail, il peut s'avérer nécessaire d'utiliser une poussette de diamètre inférieur.

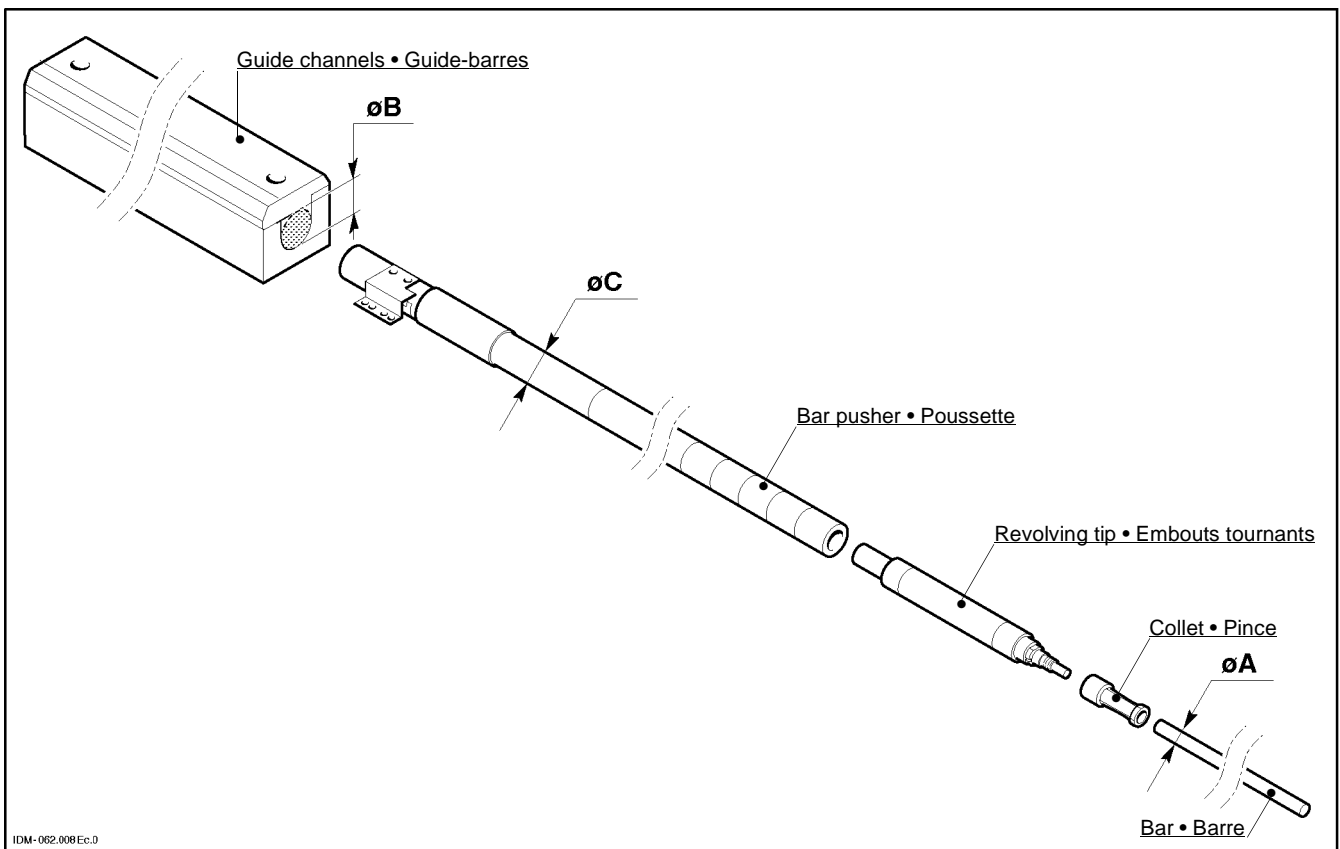



CAUTION: the field of application of collets for machining specific bar diameters in the different guide channels are indicated in the table. If the bar diameter is smaller by about 10 mm with respect to the guide channel diameter, vibrations and failures could arise in the bar feeder. Therefore, in order to optimise operation, the bar rotation speed should be reduced or the guide channel diameter should be changed.



INFORMATION: upon request also non standard collets with reduced thickness (which are not mentioned in the a.m. table) are available. Their durability is however below the durability of standard collets.



PRECAUTION: le champ d'application des pinces pour les diamètres des barres usinables dans chaque guide-barre est celui qui est indiqué sur le tableau. Lorsque ce diamètre est plus petit de 10 mm que le diamètre du guide-barre, peuvent se créer des vibrations et des défaillances sur le chargeur. Il faut donc considérer la possibilité de réduire la vitesse de rotation de la barre ou bien de changer le diamètre du guide-barre pour optimiser l'application.



AVERTISSEMENT: sur demandes spécifiques des clients, nous pouvons fournir des pinces pas standard (pas indiquées sur le tableau), avec des épaisseurs plus minces, qui évidemment ne garantissent pas la même durée que celles de dotation.

Bar diameter - $\varnothing A$ (mm) Diamètre barre - $\varnothing A$ (mm)		$\varnothing A$ (mm) Maximum tube diameter (*) Diamètre maximum des tubes (*)	$\varnothing B$ (mm) Guide channel diameter Diamètre des guide-barres	$\varnothing C$ (mm) Bar pusher diameter Diamètre de la poussette
Min	Max			
8	18	20	21	20
8	23	25	26	25
10	29	31	33(**)	32
10	32	35	36	35
12	39	42	43	42
15	42	45	46	45
18	47	51	52	51
22	52	56	57	56
30	56	60	61(**)	60
38	61	65	66	65
48	63	68	69	68
48	65	70	71	70
50	67	72	73	72
50	70	75	76	75
52	75	80	81	80
55	80	80	86(**)	85

(*) Also valid for prepared bars and normal barstock with front ejection of bar remnant.

(**) Recommended guide channels on the basis of the minimum bar passage of the lathe.

Example: maximum bar passage $\varnothing 85$ - GUIDE CHANNELS 86-61-33

Example: maximum bar passage $\varnothing 80$ - GUIDE CHANNELS 81-61-33

Example: maximum bar passage $\varnothing 75$ - GUIDE CHANNELS 76-61-33

(*) Valable également pour les barres préparées ou les barres normales à usinage avec éjection antérieure de la chute.

(**) Guide-barres conseillés en fonction du passage maximum de la barre du tour.

Exemple: passage maximum de la barre $\varnothing 85$ - GUIDE-BARRES 86-61-33

Exemple: passage maximum de la barre $\varnothing 80$ - GUIDE-BARRES 81-61-33

Exemple: passage maximum de la barre $\varnothing 75$ - GUIDE-BARRES 76-61-33

REVOLVING TIPS - Table

The choice of the revolving tip depends on the diameter of the guide channel, that of the bar pusher, and the collet coupling version.

EMBOUT TOURNANT - Tableau

Le choix de l'embout tournant doit être fait en fonction du diamètre des guide-barres, de celui de la poussette et de la version de l'enclenchement de la pince.

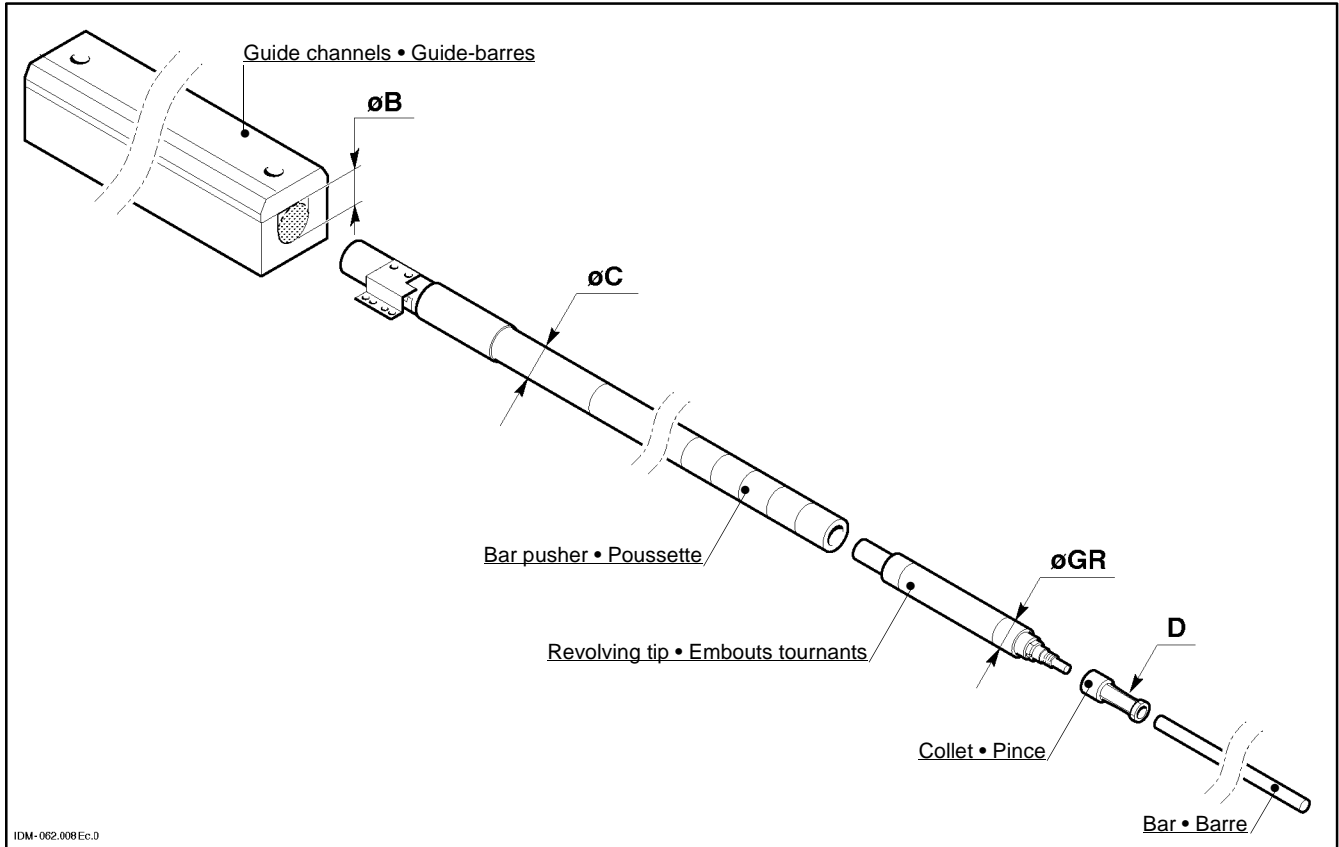
IDM-062.008Ec.0

ϕB (mm) Guide channel diameter Diamètre des guide-barres	ϕC (mm) Bar pusher diameter Diamètre de la poussette	Collet version - D (type of coupling) Version pince - D (type d'accouplement)	ϕGR (mm) Revolving tip diameter Diamètre embout tournant	Revolving tip code Code embout tournant	See section Voir section MASTER 880
21	20	Threaded (IEMCA) Fileté (IEMCA)	20	D71152000	103
		With pin (SCHL) Avec goupille (SCHL)		D71152001	
26	25	Threaded (IEMCA) Fileté (IEMCA)	25	D71152500	
		With pin (SCHL) Avec goupille (SCHL)		D71152501	
33	32	Threaded (IEMCA) Fileté (IEMCA)	32	D70153200	105
		With pin (SCHL) Avec goupille (SCHL)		D70153200	105

ϕB (mm) Guide channel diameter Diamètre des guide-barres	ϕC (mm) Bar pusher diameter Diamètre de la poussette	Collet version - D (type of coupling) Version pince - D (type d'accouplement)	ϕGR (mm) Revolving tip diameter Diamètre embout tournant	Revolving tip code Code embout tournant	See section Voir section MASTER 880
36	35	Threaded (IEMCA) Fileté (IEMCA)	35	D70153500	105
		With pin (SCHL) Avec goupille (SCHL)		D70153500	105
38	37	Threaded (IEMCA) Fileté (IEMCA)	37	D70153700	105
		With pin (SCHL) Avec goupille (SCHL)		D70153700	105
43	42	Threaded (IEMCA) Fileté (IEMCA)	42	D70154200	105
		With pin (SCHL) Avec goupille (SCHL)		D70154200	105
46	45	Threaded (IEMCA) Fileté (IEMCA)	45	D70154500	105
		With pin (SCHL) Avec goupille (SCHL)		D70154500	105
52	51	With pin (IEMCA), With screw (IEMCA) Threaded (IEMCA) "OPTIONAL" Avec goupille (SCHL) Avec vis (SCHL) Fileté (IEMCA) "OPTIONAL"	51	D77155100	106
57	56		56	D77155600	
61	60		60	D77156000	
66	65		65	D77156500	
69	68		68	D77156800	
71	70		70	D77157000	
73	72		72	D77157200	
76	75		75	D77157500	
81	80		80	D77158000	
86	85		85	D77158500	

**REVOLVING TIPS \varnothing GR 20÷25 -
Table**
**EMBOUTS TOURNANTS \varnothing GR 20÷25 -
Tableau**
 For collet with threaded coupling (IEMCA)

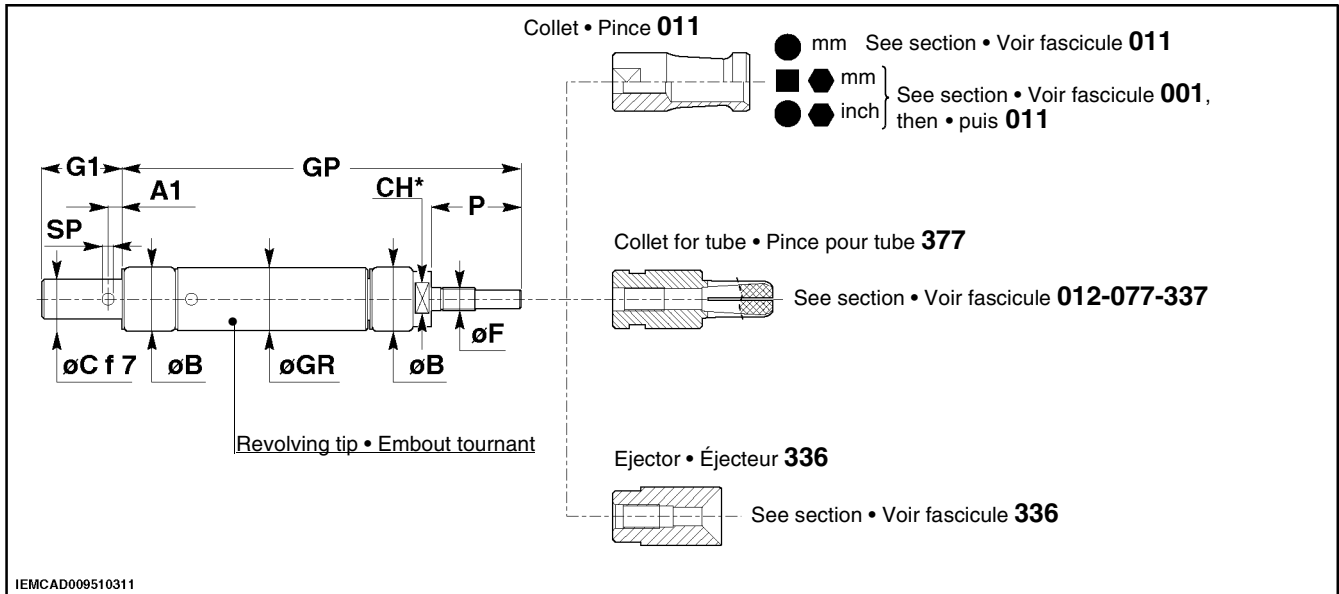
 Pour pinces à accouplement fileté (IEMCA)

(* CH: Double-ended fork wrench DIN 3110 (* CH: Clé à fourche double DIN 3110

$\varnothing GR$ (mm)	Revolving tip code Code embout tournant	$\varnothing F$	$\varnothing B$ (mm)	GP (mm)	$G1$ (mm)	C (mm)	$A1$ (mm)	$\varnothing SP$ (mm)	CH (mm)
20	D71152000	M10x1	20.5	172.5	35	14	6	4	38.5
25	D71152500	M10x1	25.5	172.5	35	17	6	5	38.5

i **INFORMATION:** Starting from May the 1st 2001 it will be possible to order revolving tips without axial backlash which are perfectly interchangeable with those listed in the relevant table. This version was designed for operating the bar feeder with "fine feed". The order code can be derived from the a.m. table as follows: Revolving tip with fine feed type IEMCA, the last two digits are 10 (Example: D71152000 standard revolving tip \varnothing 20 , D71152010 revolving tip \varnothing 20 with fine feed).

i **AVERTISSEMENT:** À partir du 01/05/2001 il sera possible de commander des Embouts tournants sans jeux axiaux et parfaitement interchangeables avec ceux qui sont indiqués sur le tableau. Cette variante a été perfectionnée pour le fonctionnement du chargeur avec "avance précise". Les codes pour la commande peuvent être tirés de ceux qui sont indiqués sur le tableau selon les modalités qui suivent : Embout tournant avec avance précise type IEMCA, les deux chiffres finaux sont 10 (exemple : D71152000 embout tournant \varnothing 20 standard , D71152010 embout tournant \varnothing 20 avec avance précise).

**REVOLVING TIPS \varnothing GR 20÷25 -
Table**
**EMBOUTS TOURNANTS \varnothing GR 20÷25 -
Tableau**

□ For collets with pin coupling (SCHL) "OPTIONAL"

□ Pour pinces à accouplement avec goupille (SCHL) "OPTIONAL"

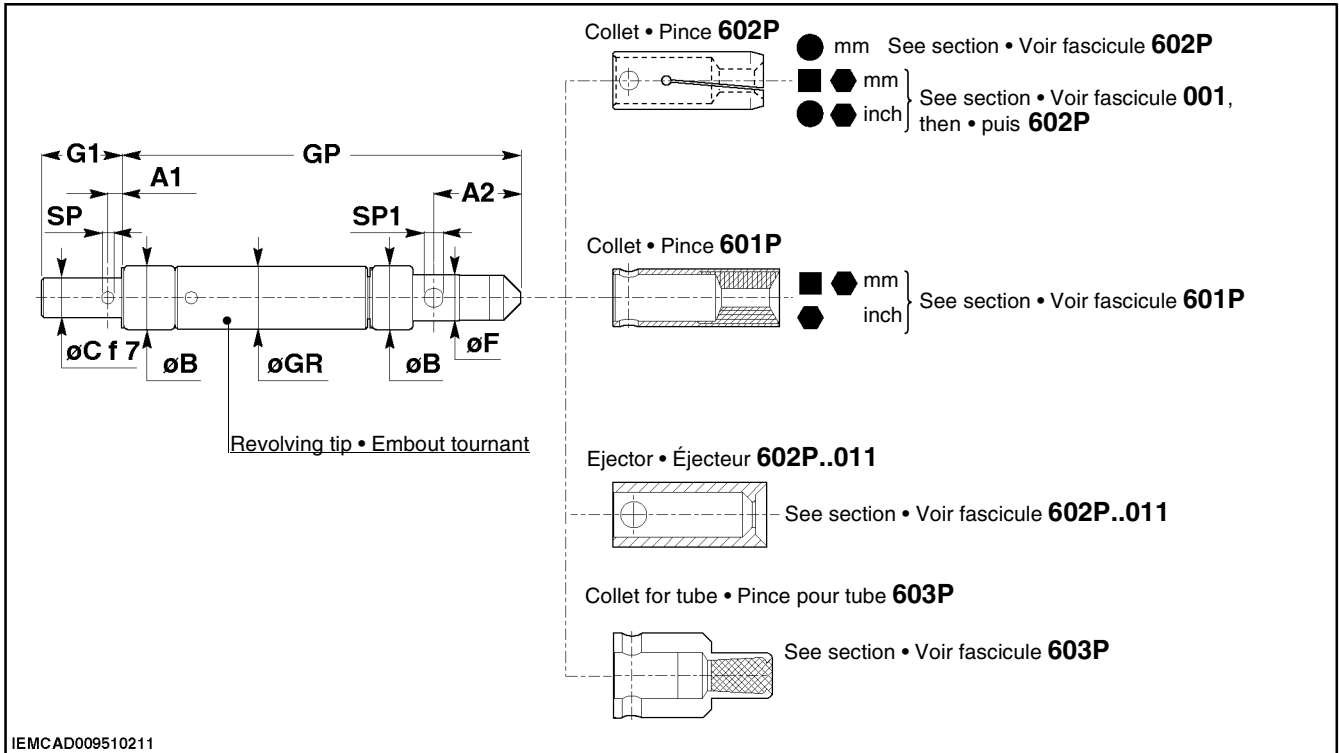
IEMCAD009510211

\varnothing GR (mm)	Revolving tip code Code embout tournant	\varnothing F (mm)	\varnothing B (mm)	GP (mm)	G1 (mm)	C (mm)	A1 (mm)	\varnothing SP (mm)	A2 (mm)	\varnothing SP1 (mm)
20	D71152001	14	20.5	172.5	35	14	6	4	37.5	8
25	D71152501	20	25.5	172.5	35	17	6	5	37.5	8

i **INFORMATION:** Starting from May the 1st 2001 it will be possible to order revolving tips without axial backlash which are perfectly interchangeable with those listed in the relevant table. This version was designed for operating the bar feeder with "fine feed". The order code can be derived from the a.m. table as follows: Revolving tip with fine feed type SCHL, the last two digits are 11 (Example: D71152001 standard revolving tip \varnothing 30, D71152011 revolving tip \varnothing 30 with fine feed).

i **INFORMATION:** À partir du 01/05/2001 il sera possible de commander des Embouts tournants sans jeux axiaux et parfaitement interchangeables avec ceux qui sont indiqués sur le tableau. Cette variante a été perfectionnée pour le fonctionnement du chargeur avec "avance précise". Les codes pour la commande peuvent être tirés de ceux qui sont indiqués sur le tableau selon les modalités qui suivent : Embout tournant avec avance précise type SCHL, les deux chiffres finaux sont 11 (exemple : D71152001 embout tournant \varnothing 30 standard, D71152011 embout tournant \varnothing 30 avec avance précise).

**REVOLVING TIPS \varnothing GR 32÷45 -
Table**
**EMBOUTS TOURNANTS \varnothing GR 32÷45
- Tableau**

□ For collet with threaded coupling (IEMCA) or with pin coupling (SCHL)

□ Pour pinces à accouplement fileté (IEMCA) ou avec goupille (SCHL)

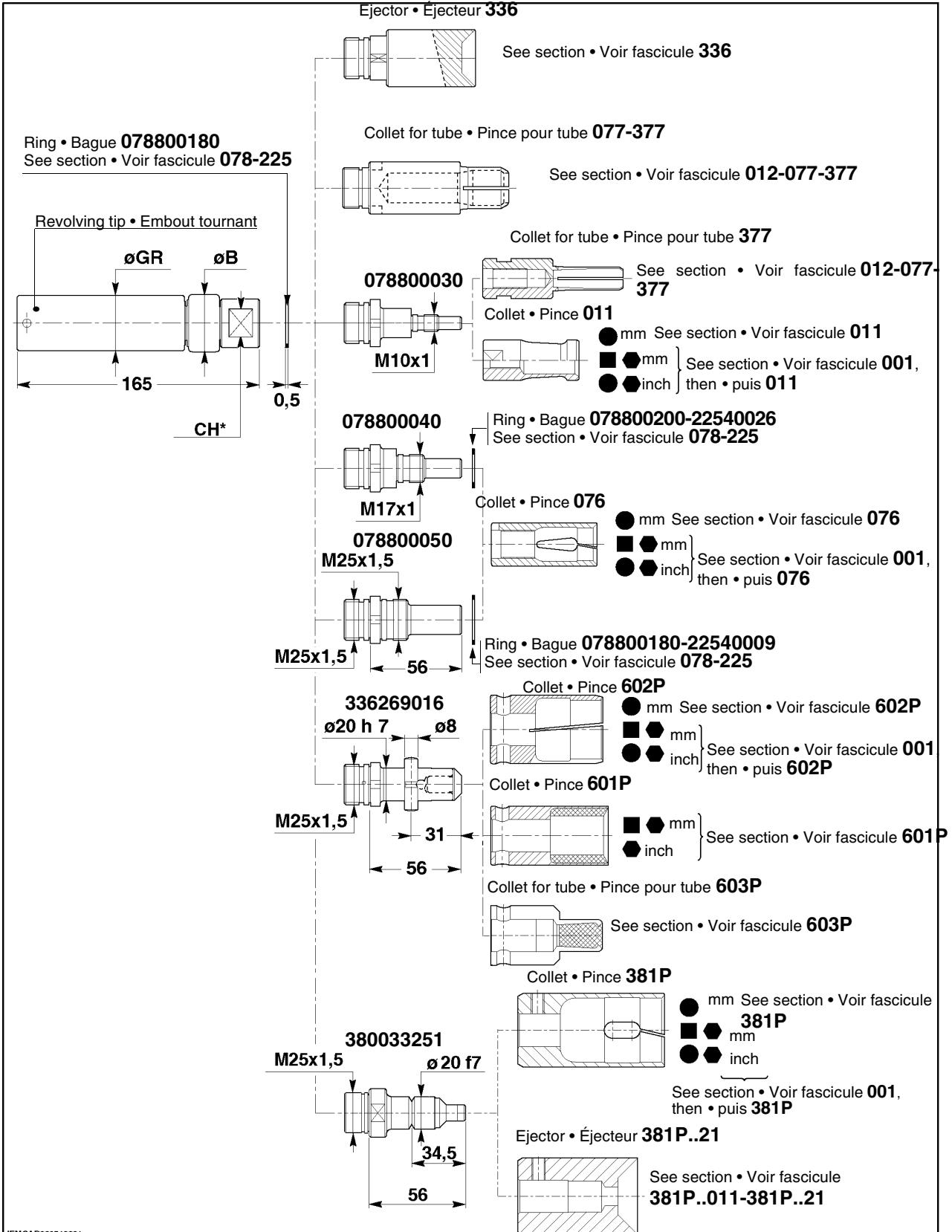

$\varnothing GR$ (mm)	Revolving tip code Code embout tournant	$\varnothing B$ (mm)	CH (mm)
32	D70153200	32.5	27
35	D70153500	35.5	27
37	D70153700	37.5	27
42	D70154200	42.5	32
45	D70154500	45.5	32

i **INFORMATION:** Starting from May the 1st 2001 it will be possible to order revolving tips without axial backlash which are perfectly interchangeable with those listed in the relevant table. This version was designed for operating the bar feeder with "fine feed". The order code can be derived from the a.m. table as follows: 1. Revolving tip with fine feed type IEMCA, the last two digits are 10 (Example: D71153200 standard revolving tip $\varnothing 20$, D71153210 revolving tip $\varnothing 20$ with fine feed). 2. Revolving tip with fine feed type SCHL, the last two digits are 11 (Example: D71153201 standard revolving tip $\varnothing 30$, D71153211 revolving tip $\varnothing 30$ with fine feed).

i **INFORMATION:** À partir du 01/05/2001 il sera possible de commander des Embouts tournants sans jeux axiaux et parfaitement interchangeables avec ceux qui sont indiqués sur le tableau. Cette variante a été perfectionnée pour le fonctionnement du chargeur avec "avance précise". Les codes pour la commande peuvent être tirés de ceux qui sont indiqués sur le tableau selon les modalités qui suivent : 1. Embout tournant avec avance précise type IEMCA, les deux chiffres finaux sont 10 (exemple : D71153200 embout tournant $\varnothing 20$ standard, D71153210 embout tournant $\varnothing 20$ avec avance précise). 2. Embout tournant avec avance précise type SCHL, les deux chiffres finaux sont 11 (exemple : D71153201 embout tournant $\varnothing 30$ standard, D71153211 embout tournant $\varnothing 30$ avec avance précise).

**REVOLVING TIPS \varnothing GR 51÷85 -
Table**
**EMBOUTS TOURNANTS \varnothing GR 51÷85
- Tableau**

□ For collets with pin coupling(IEMCA), screw coupling (IEMCA) or threaded coupling (IEMCA) "OPTIONAL"

□ Pour pinces à accouplement avec goupille (IEMCA), avec vis (IEMCA) ou fileté (IEMCA) "EN OPTION"

380032976
 $\varnothing 20\ h7$

380032991
 $\varnothing 20\ f7$

380032951
M10x1

380032961
M17x1

380032981
M25x1,5

Collet • Pince **602P**
See section • Voir fascicule **602P**

Collet • Pince **601P**
See section • Voir fascicule **601P**

Collet • Pince **603P**
See section • Voir fascicule **603P**

Collet • Pince **381P**
See section • Voir fascicule **381P**

Collet for tube • Pince pour tube **386P**
See section • Voir fascicule **386P**

Ejector • Éjecteur **381P..011**
See section • Voir fascicule **381P..11-381P..021**

Collet • Pince **011**
See section • Voir fascicule **011**

Ring • Bague **078800200-22540026**
See section • Voir fascicule **078-225**

Collet • Pince **076**
See section • Voir fascicule **076**

Ring • Bague **078800180-22540009**
See section • Voir fascicule **078-225**

STANDARD
OPTIONAL

IEMCAD009510231

\varnothing GR (mm)	Revolving tip code Code embout tournant	\varnothing B (mm)	G1 (mm)	C (mm)	L (mm)
51	D77155100	51.5	50	37	181
56	D77155600	56.5	50	40	181
60	D77156000	60.5	50	40	202

$\varnothing GR$ (mm)	<i>Revolving tip code Code embout tournant</i>	$\varnothing B$ (mm)	G1 (mm)	C (mm)	L (mm)
65	D77156500	65.5	60	46	202
68	D77156800	68.5	60	51	202
70	D77157000	70.5	60	51	202
72	D77157200	72.5	60	51	202
75	D77157500	75.5	70	60	202
80	D77158000	80.5	70	61	202
85	D77158500	85.5	70	61	202

001

CONVERSION TABLES TABLEAUX DE CONVERSION

HEXAGONAL BARS (unit of measurement "millimetres") - Table

Before selecting the steel collet, define the internal diameter ϕA by consulting the table below.

BARRES HEXAGONALES (unité de mesure "millimètres") - Tableau

Avant de procéder au choix de la pince en acier, il est nécessaire d'établir son diamètre interne ϕA , après consultation du tableau suivant.

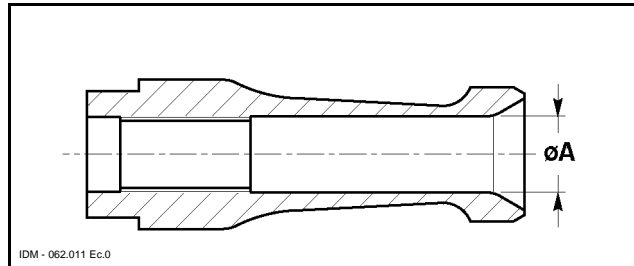

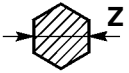
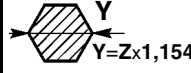
		ϕA
mm	mm	mm
1.5	1.73	1.7
2	2.31	2.2
2.5	2.89	2.8
3	3.48	3.25
3.5	4.04	3.8
4	4.61	4.5
4.5	5.19	5
5	5.77	5.5
5.5	6.35	6.2
6	6.92	6.8
6.5	7.50	7.3
7	8.08	7.8
7.5	8.66	8.5
8	9.23	9
9	10.39	10.2
10	11.54	11.3
11	12.70	12.5
12	13.85	13.5
13	15.02	14.8
14	16.16	16
15	17.32	17.2
16	18.47	18.3
17	19.62	19.5
18	20.78	20.6
19	21.93	21.8
20	23.09	22.8
21	24.24	24
22	25.40	25.2
23	26.55	26.2
24	27.71	27.5
25	28.86	28.5
26	30.02	29.8
27	31.17	31

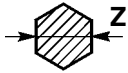
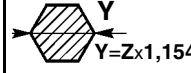
		ϕA
mm	mm	mm
28	32.33	32
29	33.48	33.2
30	34.64	34.5
31	35.79	35.5
32	36.95	36.8
33	38.10	37.8
34	39.25	39
35	40.41	40.2
36	41.56	41.3
38	43.87	43.5
39	45.03	44.8
40	46.18	46
41	47.34	47
42	48.49	48.2
43	49.65	49.5
44	50.80	50.5
45	51.96	51.8
46	53.11	52.8
48	55.42	55
50	57.73	57.5
52	60.04	59.5
55	63.50	63
57	65.78	65.25
60	69.24	68.75
62	71.55	71
65	75	74.5
67	77.3	76.75
70	80.78	80.25
72	83.08	82.5
75	86.55	86
80	92.32	91.75
85	98.1	97.5

SQUARE BARS (unit of measurement "millimetres") - Table

Before selecting the steel collet, define the internal diameter $\varnothing A$ by consulting the table below.

BARRES CARRÉES (unité de mesure "millimètres") - Tableau

Avant de procéder au choix de la pince en acier, il est nécessaire d'établir son diamètre interne $\varnothing A$, après consultation du tableau suivant.

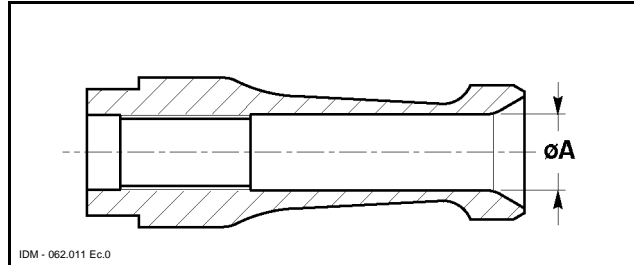

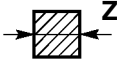
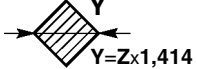
		$\varnothing A$
mm	mm	mm
1	1.41	1.3
1.5	2.12	2
2	2.82	2.7
2.5	3.53	3.4
3	4.24	4
4	5.65	5.5
4.5	6.36	6.2
5	7.07	6.8
5.5	7.77	7.5
6	8.48	8.3
6.5	9.19	9
7	9.89	9.7
8	11.31	11
8.5	12.01	11.8
9	12.72	12.5
10	14.14	13.8
10.5	14.84	14.5
11	15.55	15
12	16.97	16.5
12.5	17.67	17
13	18.38	18
14	19.79	19.5
15	21.21	20.8
16	22.62	22
17	24.04	23.5
18	25.52	25
19	26.86	26

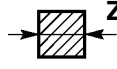
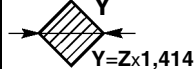
		$\varnothing A$
mm	mm	mm
20	28.28	27.5
22	31.10	30.5
23	32.52	32
24	33.93	33
25	35.35	34.5
26	36.76	36
27	38.17	37.5
28	39.59	38.5
30	42.42	41.5
32	45.24	44.5
34	48.07	47
35	49.49	48.5
36	50.90	50
37	52.31	51.5
38	53.73	52.5
39	55.15	54.5
40	56.56	55.5
41	57.97	57
42	59.38	58.5
43	60.08	59
44	62.21	61
45	63.63	62.5
46	65.04	64
50	70.7	69.5
55	77.77	76.75
60	84.84	83.75
65	91.91	91

HEXAGONAL BARS (unit of measurement "inches") - Table

Before selecting the steel collet, define the internal diameter ϕA by consulting the table below.

BARRES HEXAGONALES (unité de mesure "pouces") - Tableau

Avant de procéder au choix de la pince en acier, il est nécessaire d'établir son diamètre interne ϕA , après consultation du tableau suivant.

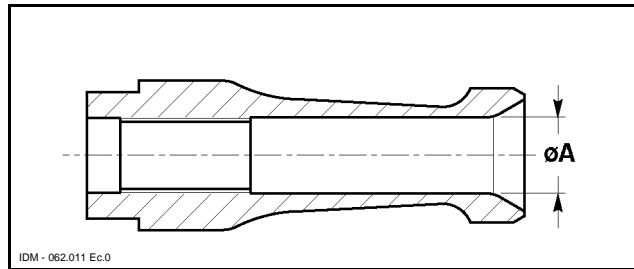

	ϕA	
	mm	inch
1/8	3.5	9/64
3/16	5.25	13/64
1/4	7	9/32
5/16	8.75	11/32
3/8	10.75	27/64
7/16	12.5	31/64
1/2	14.25	9/16
9/16	16.25	41/64
5/8	18	45/64
11/16	19.75	25/32
3/4	21.75	55/64
13/16	23.5	59/64
7/8	25.25	63/64
15/16	27.25	1"5/64
1"	29	1"9/64
1"1/16	30.75	1"13/64
1"1/8	32.5	1"9/32
1"3/16	34.25	1"11/32
1"1/4	36.25	1"27/64
1"5/16	38	1"1/2

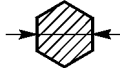
	ϕA	
	mm	inch
1"3/8	39.75	1"9/16
1"7/16	41.75	1"41/64
1"1/2	43.5	1"23/32
1"9/16	46.5	1"53/64
1"5/8	47.25	1"55/64
1"11/16	49	1"15/16
1"3/4	50.75	2"
1"13/16	52.75	2"5/64
1"7/8	54.5	2"9/64
1"15/16	56.25	2"7/32
2"	58	2"9/32
2"1/16	59.75	2"11/32
2"1/8	61.5	2"27/64
2"3/16	63.5	2"1/2
2"1/4	65.25	2"37/64
2"1/2	72.5	2"55/64
2"3/4	79.75	3"9/64
3"	87	3"27/64
3"1/4	94.25	3"23/32

ROUND BARS (unit of measurement "inches") - Table

Before selecting the steel collet, define the internal diameter $\varnothing A$ by consulting the table below.

BARRES RONDES (unité de mesure "pouces") - Tableau

Avant de procéder au choix de la pince en acier, il est nécessaire d'établir son diamètre interne $\varnothing A$, après consultation du tableau suivant.

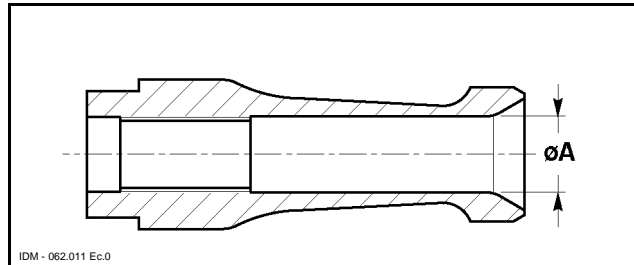

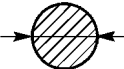
	$\varnothing A$
<i>inch</i>	<i>mm</i>
1/32	0.8
3/64	1.2
1/16	1.6
5/64	2
3/32	2.4
7/64	2.8
1/8	3.2
9/64	3.6
5/32	4
11/64	4.4
3/16	4.8
13/64	5.2
7/32	5.6
15/64	6
1/4	6.4
17/64	6.8
9/32	7.2
19/64	7.6
5/16	8
21/64	8.4
11/32	8.8
23/64	9.1
3/8	9.6
25/64	10
13/32	10.4
27/64	10.8
7/16	11.25
29/64	11.5
15/32	12
31/64	12.5
1/2	12.75
33/64	13.25

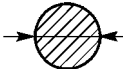
	$\varnothing A$
<i>inch</i>	<i>mm</i>
17/32	13.5
35/64	14
9/16	14.25
37/64	14.75
19/32	15
39/64	15.5
5/8	16
41/64	16.25
21/32	16.75
43/64	17
11/16	17.5
45/64	18
23/32	18.25
47/64	18.75
3/4	19
49/64	19.5
25/32	19.75
51/64	20.25
13/16	20.75
53/64	21
27/32	21.5
55/64	21.75
7/8	22.25
57/64	22.75
29/32	23
59/64	23.5
15/16	24
61/64	24.25
31/32	24.75
63/64	25
1	25.5
1"1/16	27

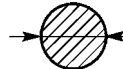
	$\varnothing A$
<i>inch</i>	<i>mm</i>
1"1/8	28.5
1"3/16	30.25
1"1/4	31.75
1"5/16	33.25
1"3/8	35
1"7/16	36.25
1"1/2	38
1"9/16	39.75
1"5/8	41.25
1"11/16	43
1"3/4	44.5
1"13/16	46
1"7/8	47.75
1"15/16	49.25
2"	50.75
2"1/16	52.5
2"1/8	54
2"3/16	55.5
2"1/4	57.25
2"5/16	58.75
2"3/8	60.5
2"7/16	62
2"1/2	63.5
2"9/16	65
2"5/8	66.75
2"11/16	68.25
2"3/4	70
2"13/16	71.5
2"7/8	73
2"15/16	74.75
3"	76.25

INCH/MM CONVERSION TABLE
TABLE DE CONVERSION POUCES / MILLIMÈTRES

Inch fraction Fraction de pouce		Inch/pouces			
		0	1	2	3
		MM/millimètres			
0	0	0	25,400 0	50,800 0	76,200 0
1/64	0,015 625	0,396 9	25,796 9	51,196 9	76,596 9
1/32	0,031 25	0,793 8	26,193 8	51,593 8	76,993 8
3/64	0,046 875	1,190 6	26,590 6	51,990 6	77,390 6
1/16	0,062 5	1,587 5	26,987 5	52,387 5	77,787 5
5/64	0,078 125	1,984 4	27,384 4	52,784 4	78,184 4
3/32	0,093 75	2,381 2	27,781 2	53,181 2	78,581 2
7/64	0,109 375	2,778 1	28,178 1	53,578 1	78,978 1
1/8	0,125	3,175 0	28,575 0	53,985 0	79,375 0
9/64	0,140 625	3,571 9	28,971 9	54,371 9	79,771,9
5/32	0,156 25	3,968 8	29,368 8	54,768 8	80,168 8
11/64	0,171 875	4,365 6	29,765 6	55,165 6	80,565 6
3/16	0,187 5	4,762 5	30,162 5	55,562 5	80,962 5
13/64	0,203 125	5,159 4	30,559 4	55,959 4	81,359 4
7/32	0,218 75	5,556 2	30,956 2	56,356 2	81,756 2
15/64	0,234 375	5,953 1	31,353 1	56,753 1	82,153 1
1/4	0,25	6,350 0	31,750 0	57,150 0	82,550 0
17/64	0,265 625	6,746 9	32,146 9	57,546 9	82,946 9
9/32	0,281 25	7,143 8	32,543 8	57,943 8	83,343 8
19/64	0,296 875	7,540 6	32,940 6	58,340 6	83,740 6
5/16	0,312 5	7,937 5	33,337 5	58,737 5	84,137 5
21/64	0,328 125	8,334 4	33,734 4	59,134 4	84,534 4
11/32	0,343 75	8,731 2	34,131 2	59,531 2	84,931 2
23/64	0,359 375	9,128 1	34,528 1	59,928 1	85,328 1
3/8	0,375	9,525 0	34,925 0	60,325 0	85,725 0
25/64	0,390 625	9,921 9	35,321 9	60,721 9	86,121 9
13/32	0,406 25	10,318 8	35,718 8	61,118 8	86,518 8
27/64	0,421 875	10,715 6	36,115 6	61,515 6	86,915 6
7/16	0,437 5	11,112 5	36,512 5	61,912 5	87,312 5
29/64	0,453 125	11,509 4	36,909 4	62,309 4	87,709 4
15/32	0,468 75	11,906 2	37,306 2	62,706 2	88,106 2
31/64	0,484 375	12,303 1	37,703 1	63,103 1	88,503 1
1/2	0,5	12,700 0	38,100 0	63,500 0	88,900 0
33/64	0,515 625	13,096 9	38,496 9	63,896 9	89,296 9
17/32	0,531 25	13,493 8	38,893 8	64,293 8	89,693 8
35/64	0,546 875	13,890 6	39,290 6	64,690 6	90,090 6
9/16	0,562 5	14,287 5	39,687 5	65,087 5	90,487 5
37/64	0,578 125	14,684 4	40,084 4	65,484 4	90,884 4
19/32	0,593 75	15,081 2	40,481 2	65,881 2	91,281 2
39/64	0,609 375	15,478 1	40,878 1	66,278 1	91,678 1
5/8	0,625	15,875 0	41,275 0	66,675 0	92,075 0
41/64	0,640 625	16,271 9	41,671 9	67,071 9	92,471 9
21/32	0,656 25	16,668 8	42,068 8	67,468 8	92,868 8
43/64	0,671 875	17,065 6	42,465 6	67,865 6	93,265 6
11/16	0,687 5	17,462 5	42,862 5	68,262 5	93,662 5
45/64	0,703 125	17,859 4	43,259 4	68,659 4	94,059 4
23/32	0,718 75	18,256 2	43,656 2	69,056 2	94,456 2
47/64	0,734 375	18,653 1	44,053 1	69,453 1	94,853 1
3/4	0,75	19,050 0	44,450 0	69,850 0	95,250 0
49/64	0,765 625	19,446 9	44,846 9	70,246 9	95,646 9
25/32	0,781 25	19,843 8	45,243 8	70,643 8	96,043 8
51/64	0,796 875	20,240 6	45,640 6	71,040 6	96,440 6
13/16	0,812 5	20,637 5	46,037 5	71,437 5	96,837 5
53/64	0,828 125	21,034 4	46,434 4	71,834 4	97,234 4
27/32	0,843 75	21,431 2	46,831 2	72,231 2	97,631 2
55/64	0,859 375	21,828 1	47,228 1	72,628 1	98,028 1
7/8	0,875	22,225 0	47,625 0	73,025 0	98,425 0
57/64	0,890 625	22,621 9	48,021 9	73,421 9	98,821 9
29/32	0,906 25	23,018 8	48,418 8	73,818 8	99,218 8
59/64	0,921 875	23,415 6	48,815 6	74,215 6	99,615 6
15/16	0,937 5	23,812 5	49,212 5	74,612 5	100,012 5
61/64	0,953 125	24,209 4	49,609 4	75,009 4	100,409 4
31/32	0,968 75	24,606 2	50,006 2	75,406 2	100,806 2
63/64	0,984 375	25,003 1	50,403 1	75,803 1	101,203 1

011

COLLETS FOR BARS PINCES POUR BARRES

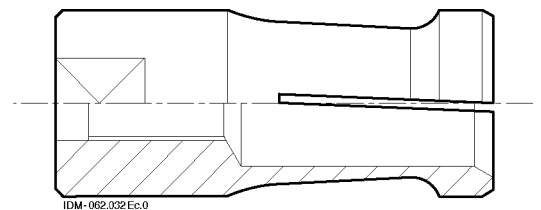

011 COLLETS FOR BARS - Table

CAUTION: the external diameter of the collet must be at least 0.5 mm less than the external diameter of the bar pusher.

Note for consultation

Codes on a grey background refer to the "USE RANGE" for completing a set of collets while working with the larger channel, and coupling ϕF on the revolving tip is the same.

Note for ordering

- Collets with codes in bold characters are available from stock.
- Collets with codes in italics have longer delivery times.

011 PINCES POUR BARRES - Tableau

PRECAUTION: le diamètre externe de la pince doit être inférieur d'au moins 0,5 mm au diamètre externe de la poussette.

Note pour la consultation

Les codes sur fond gris indiquent le "GROUPE D'UTILISATION" pour compléter un jeu de pinces quand l'usinage a lieu sur le guide-barre le plus important, et que l'enclenchement ϕF sur l'embout tournant est le même.

Remarque pour la commande

- Les pinces qui ont les codes en gras sont disponibles dans le magasin.
- Les pinces qui ont les codes en italique ont un délai de livraison plus long.

Collet • Pince

IEMCAD000610331

(*)CH: Double-ended fork wrench DIN3110
(*)CH: Clé à fourche double DIN3110

Code structure

Structure du code

011

12

030

0

ϕA Bar diameter
 ϕA Diamètre de la barre
 Exemple 0.8 mm = 008
 Exemple 3 mm = 030
 12.25 mm = 122
 12.5 mm = 125

ϕD

Family to which it belongs
Groupe d'appartenance

ϕA		ϕF M5x0.5 CH6	ϕF M6x0.75 CH8	ϕF M7x0.75 CH10			
		ϕD 7.5	ϕD 10	ϕD 12			
mm	in						
0.8	1/32"	011070080					
0.9		011070090					
1		011070100	011100100	011120100			
1.2	3/64"	011070120	011100120	011120120			
1.3		011070130	011100130	011120130			
1.4		011070140	011100140	011120140			
1.5		011070150	011100150	011120150			
1.6	1/16"	011070160	011100160	011120160			
1.7		011070170	011100170	011120170			
1.8		011070180	011100180	011120180			
1.9		011070190	011100190	011120190			

øA		øF M5x0.5 CH6	øF M6x0.75 CH8	øF M7x0.75 CH10	øF M8x1 CH13	øF M10x1 CH17	
mm	in	øD 7.5	øD 10	øD 12	øD 15	øD 20	
2	5/64"	011070200	011100200	011120200			
2.1		011070210	011100210	011120210			
2.2		011070220	011100220	011120220			
2.3		011070230	011100230	011120230			
2.4	3/32"	011070240	011100240	011120240			
2.5		011070250	011100250	011120250			
2.6		011070260	011100260	011120260			
2.7		011070270	011100270	011120270			
2.8	7/64"	011070280	011100280	011120280			
2.9		011070290	011100290	011120290			
3		011070300	011100300	011120300	011150300		
3.1		011070310	011100310	011120310	011150310		
3.2	1/8"	011070320	011100320	011120320	011150320		
3.3		011070330	011100330	011120330	011150330		
3.4		011070340	011100340	011120340	011150340		
3.5		011070350	011100350	011120350	011150350		
3.6	9/64"	011070360	011100360	011120360	011150360		
3.7		011070370	011100370	011120370	011150370		
3.8		011070380	011100380	011120380	011150380		
3.9		011070390	011100390	011120390	011150390		
4	5/32"	011070400	011100400	011120400	011150400	011200400	
4.1		011070410	011100410	011120410	011150410	011200410	
4.2		011070420	011100420	011120420	011150420	011200420	
4.3		011070430	011100430	011120430	011150430	011200430	
4.4	11/64"	011070440	011100440	011120440	011150440	011200440	
4.5		011070450	011100450	011120450	011150450	011200450	
4.6		011070460	011100460	011120460	011150460	011200460	
4.7		011070470	011100470	011120470	011150470	011200470	
4.8	3/16	011070480	011100480	011120480	011150480	011200480	
4.9		011070490	011100490	011120490	011150490	011200490	
5		011070500	011100500	011120500	011150500	011200500	
5.1		011070510	011100510	011120510	011150510	011200510	
5.2	13/64"	011070520	011100520	011120520	011150520	011200520	
5.3		011070530	011100530	011120530	011150530	011200530	
5.4		011070540	011100540	011120540	011150540	011200540	
5.5		011070550	011100550	011120550	011150550	011200550	
5.6	7/32"	011070560	011100560	011120560	011150560	011200560	
5.7		011070570	011100570	011120570	011150570	011200570	
5.8		011070580	011100580	011120580	011150580	011200580	

$\varnothing A$		$\varnothing F M5 \times 0.5$ CH6	$\varnothing F M6 \times 0.75$ CH8	$\varnothing F M7 \times 0.75$ CH10	$\varnothing F M8 \times 1$ CH13	$\varnothing F M10 \times 1$ CH17	
mm	in	$\varnothing D 7.5$	$\varnothing D 10$	$\varnothing D 12$	$\varnothing D 15$	$\varnothing D 20$	
5.9		011070590	011100590	011120590	011150590	011200590	
6	15/64"	011070600	011100600	011120600	011150600	011200600	
6.1		011070610	011100610	011120610	011150610	011200610	
6.2		011070620	011100620	011120620	011150620	011200620	
6.3		011070630	011100630	011120630	011150630	011200630	
6.4	1/4"	011070640	011100640	011120640	011150640	011200640	
6.5		011070650	011100650	011120650	011150650	011200650	
6.6		011070660	011100660	011120660	011150660	011200660	
6.7		011070670	011100670	011120670	011150670	011200670	
6.8	17/64"		011100680	011120680	011150680	011200680	
6.9			011100690	011120690	011150690	011200690	
7			011100700	011120700	011150700	011200700	
7.1			011100710	011120710	011150710	011200710	
7.2	9/32"		011100720	011120720	011150720	011200720	
7.3			011100730	011120730	011150730	011200730	
7.4			011100740	011120740	011150740	011200740	
7.5			011100750	011120750	011150750	011200750	
7.6	19/64"		011100760	011120760	011150760	011200760	
7.7			011100770	011120770	011150770	011200770	
7.8			011100780	011120780	011150780	011200780	
7.9			011100790	011120790	011150790	011200790	
8	5/16"		011100800	011120800	011150800	011200800	
8.1			011100810	011120810	011150810	011200810	
8.2			011100820	011120820	011150820	011200820	
8.3			011100830	011120830	011150830	011200830	
8.4	21/64"		011100840	011120840	011150840	011200840	
8.5			011100850	011120850	011150850	011200850	
8.6			011100860	011120860	011150860	011200860	
8.7			011100870	011120870	011150870	011200870	
8.8	11/32"		011100880	011120880	011150880	011200880	
8.9			011100890	011120890	011150890	011200890	
9			011100900	011120900	011150900	011200900	
9.1	23/64"			011120910	011150910	011200910	
9.2				011120920	011150920	011200920	
9.3				011120930	011150930	011200930	
9.4				011120940	011150940	011200940	

øA		øF M7x0.75 CH10	øF M8x1 CH13	øF M8x1 CH13	øF M8x1 CH13	øF M8x1 CH16	øF M10x1 CH17
mm	in	øD 12	øD 15	øD 16	øD 17	øD 18	øD 20
9.5		011120950	011150950				011200950
9.6	3/8"	011120960	011150960				011200960
9.7		011120970	011150970				011200970
9.8		011120980	011150980				011200980
9.9		011120990	011150990				011200990
10	25/64"	011121000	011151000				011201000
10.1		011121010	011151010				011201010
10.2		011121020	011151020				011201020
10.3		011121030	011151030				011201030
10.4	13/32"	011121040	011151040				011201040
10.5		011121050	011151050				011201050
10.6		011121060	011151060				011201060
10.7		011121070	011151070				011201070
10.8	27/64"	011121080	011151080				011201080
10.9		011121090	011151090				011201090
11		011121100	011151100				011201100
11.25	7/16"		011151120	011161120			011201120
11.5			011151150	011161150			011201150
11.75	13/64"		011151170	011161170			011201170
12			011151200	011161200			011201200
12.25			011151220	011161220			011201220
12.5	31/64"		011151250	011161250		011181250	011201250
12.75	1/2"		011151270	011161270		011181270	011201270
13			011151300	011161300		011181300	011201300
13.25			011151320	011161320		011181320	011201320
13.5			011151350	011161350		011181350	011201350
13.75			011151370	011161370		011181370	011201370
14			011151400	011161400	011171400	011181400	011201400
14.25	9/16"			011161420	011171420	011181420	011201420
14.5				011161450	011171450	011181450	011201450
14.75				011161470	011171470	011181470	011201470
15				011161500	011171500	011181500	011201500
15.25					011171520	011181520	011201520
15.5					011171550	011181550	011201550
15.75					011171570	011181570	011201570
16	5/8"				011171600	011181600	011201600
16.25						011181620	011201620
16.5						011181650	011201650

øA		øF M8x1 CH16	øF M10x1 CH17	øF M10x1 CH19	øF M10x1 CH22	øF M10x1 CH24	øF M10x1 CH28
mm	in	øD 19	øD 20	øD 23	øD 25	øD 27	øD 30
14			011201400	011231400			
14.25			011201420	011231420			
14.5			011201450	011231450			
14.75			011201470	011231470			
15			011201500	011231500			
15.25			011201520	011231520			
15.5			011201550	011231550			
15.75			011201570	011231570			
16	5/8"		011201600	011231600			
16.25	41/64"	011191620	011201620	011231620			
16.5		011191650	011201650	011231650			
16.75		011191670	011201670	011231670			
17		011191700	011201700	011231700	011251700		
17.25		011191720	011201720	011231720	011251720		
17.5	11/16"	011191750	011201750	011231750	011251750		
17.75		011191770	011201770	011231770	011251770		
18	45/64"	011191800	011201800	011231800	011251800		
18.25				011231820	011251820		
18.5				011231850	011251850		
18.75				011231870	011251870		
19	3/4"			011231900	011251900	011271900	
19.25				011231920	011251920	011271920	
19.5				011231950	011251950	011271950	
19.75	25/32"			011231970	011251970	011271970	
20				011232000	011252000	011272000	
20.25				011232020	011252020	011272020	
20.5				011232050	011252050	011272050	
20.75	13/16"			011232070	011252070	011272070	
21				011232100	011252100	011272100	
21.25					011252120	011272120	
21.5					011252150	011272150	
21.75	56/64"				011252170	011272170	
22					011252200	011272200	
22.25	7/8"				011252220	011272220	
22.5					011252250	011272250	
22.75					011252270	011272270	
23					011252300	011272300	011302300
23.25						011272320	011302320
23.5	59/64"					011272350	011302350

øA		øF M10x1 CH24	øF M10x1 CH24	øF M10x1 CH28	øF M10x1 CH30		
<i>mm</i>	<i>in</i>	øD 27	øD 29	øD 30	øD 32		
23.75		011272370		011302370			
24	15/16"	011272400	<i>011292400</i>	011302400			
24.25		011272420	<i>011292420</i>	011302420			
24.5		011272450	<i>011292450</i>	011302450			
24.75		011272470	<i>011292470</i>	011302470			
25		011272500	<i>011292500</i>	011302500			
25.25	63/64"		<i>011292520</i>	011302520			
25.5	1"		<i>011292550</i>	011302550			
25.75			<i>011292570</i>	011302570			
26			<i>011292600</i>	011302600	011322600		
26.25				011302620	011322620		
26.5				011302650	011322650		
26.75	1"1/16			011302670	011322670		
27	1"5/64			011302700	011322700		
27.25				011302720	011322720		
27.5				011302750	011322750		
27.75				011302770	011322770		
28				011302800	011322800		
28.25	1"1/8				011322820		
28.5					011322850		
28.75					011322870		
29					011322900		
29.25					011322920		
29.5					011322950		
29.75					011322970		
30					011323000		

012 - 077 - 377

**COLLETS FOR TUBES
PINCES POUR TUBES**

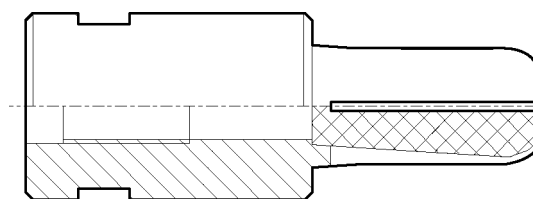

IDM-062.033 Ec.0

012-077-377 COLLETS FOR TUBES - Table

CAUTION: the external diameter of the collet must be at least 0.5 mm less than the external diameter of the bar pusher.

INFORMATION: Collets 377... with ϕF M10x1 are designed for being mounted on revolving tips under $\phi 28$. When mounted on revolving tips $< \phi 30$ and nipples 078800030, the 1st feeding value shall be increased by 7.5 mm.

012-077-377 PINCES POUR TUBES - Tableau

PRECAUTION: le diamètre externe de la pince doit être inférieur d'au moins 0,5 mm au diamètre externe de la poussette.

AVERTISSEMENT: Les pinces 377 avec ϕF M10x1 ont été projetées pour être installées sur des embouts tournants inférieurs à $\phi 28$. En cas que celles-ci soient installées sur des embouts tournants $< \phi 30$ et avec des nipples type 078800030, il faudra étendre la cote de préavancement de 7,5 mm.

012 Collets for tubes (type AS) ϕF M7x0.75 - M8x1
Pincés pour tubes (type AS) ϕF M7x0.75 - M8x1

377 Collets for tubes (type BOSS) ϕF M10x1
Pincés pour tubes (type BOSS) ϕF M10x1

077 Collets for tubes (type T560) ϕF M17x1 - M25x1
Pincés pour tubes (type T560) ϕF M17x1 - M25x1

377 Collets for tubes (type T560) ϕF M25x1.5
Pincés pour tubes (type T560) ϕF M25x1.5

Code structure

Structure du code

377

29

100

0

ϕA Bar diameter
 ϕA Diamètre de la barre

Example: 5 mm = 060
Exemple: 10 mm = 100
12.5 mm = 125

ϕD

Family to which it belongs • Groupe d'appartenance

012 Collets for tubes (type AS) ϕF M7x0.75 - M8x1
Pincés pour tubes (type AS) ϕF M7x0.75 - M8x1

077 Collets for tubes (type T560) ϕF M17x1 - M25x1
Pincés pour tubes (type T560) ϕF M17x1 - M25x1

377 Collets for tubes (type BOSS) ϕF M10x1
Pincés pour tubes (type BOSS) ϕF M10x1

377 Collets for tubes (type T560) ϕF M25x1.5
Pincés pour tubes (type T560) ϕF M25x1.5

(*)CH: Double-ended fork wrench DIN3110

(*)CH: Clé à collier de serrage DIN3110

ϕA		ϕF M7x0.75 CH10	ϕF M8x1 CH13	ϕF M10x1 CH17	ϕF M17x1 CH22	ϕF M10x1 CH22	ϕF M10x1 CH24	ϕF M25x1.5 CH27
mm	in	ϕD 12	ϕD 15	ϕD 20	ϕD 24	ϕD 25	ϕD 27	ϕD 29
5		012120500	012150500					
5.5		012120550	012150550					
6	15/64"	012120600	012150600	377200600	077240600			
6.5		012120650	012150650	377200650	077240650			
7		012120700	012150700	377200700	077240700			
7.5		012120750	012150750	377200750	077240750			
8	5/16"	012120800	012150800	377200800	077240800			
8.5		012120850	012150850	377200850	077240850			
9		012120900	012150900	377200900	077240900			
9.5		012120950	012150950	377200950	077240950			
10	25/64"		012151000	377201000	077241000			377291000
10.5			012151050	377201050	077241050			377291050

øA		øF M25x1.5 CH36	øF M25x1.5 CH38	øF M25x1.5 CH41	øF M25x1.5 CH46	øF M25x1.5 CH50		
<i>mm</i>	<i>in</i>	øD 40	øD 42	øD 44-45	øD 49	øD 54-55		
34		377403400						
35	1"3/8	377403500						
36		377403600						
37		377403700						
38	1"1/2		377423800					
39			377423900					
40			377424000	377444000				
40.5				377444050				
41				377444100				
41.5				377444150				
42				377454200				
42.5				377454250				
43	1"11/16				377494300			
43.5					377494350			
44					377494400			
44.5	1"3/4				377494450			
45					377494500			
45.5					377494550			
46					377494600			
46.5						377544650		
47						377544700		
47.5						377544750		
48						377544800		
48.5						377544850		
49						377544900		
49.5						377544950		
50						377545000		
50.5						377545050		
51						377545100		
51.5						377545150		
52						377555200		

øA		øF M25x1.5 CH55	øF M25x1.5 CH60	øF M25x1.5 CH60
<i>mm</i>	<i>in</i>	øD 59	øD 64	øD 68
52.5		377595250		
53		377595300		
53.5		377595350		
54	2"1/8	377595400		
54.5		377595450		
55		377595500		
55.5		377595600		
56		377595600		
56.5			377645650	
57			377645700	
57.5			377645750	
58			377645800	
58.5			377645850	
59			377645900	
59.5			377646000	
60			377646000	
60.5			377646050	
61			377646100	
61.5				377686150
62				377686200
62.5				377686250
63				377686300
63.5				377686350
64				377686400
64.5				377686450
65				377686500
65.5				377686550
66				377686600

076

**COLLETS FOR TUBES
PINCES POUR TUBES**

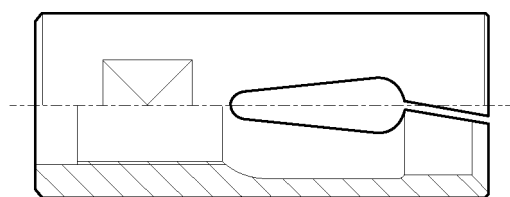

IDM - 062.034 Ec.0

076 COLLETS FOR BARS - Table

CAUTION: the external diameter of the collet must be at least 0.5 mm less than the external diameter of the bar pusher.

Note for consultation

The Codes on a grey background refer to the "USE RANGE" to for complete a set of collets while working with the larger channel, and coupling ϕF on the revolving tip is the same.

Note for ordering

- Collets with codes in bold characters are available from stock.
- Collets with codes in italics have longer delivery times.

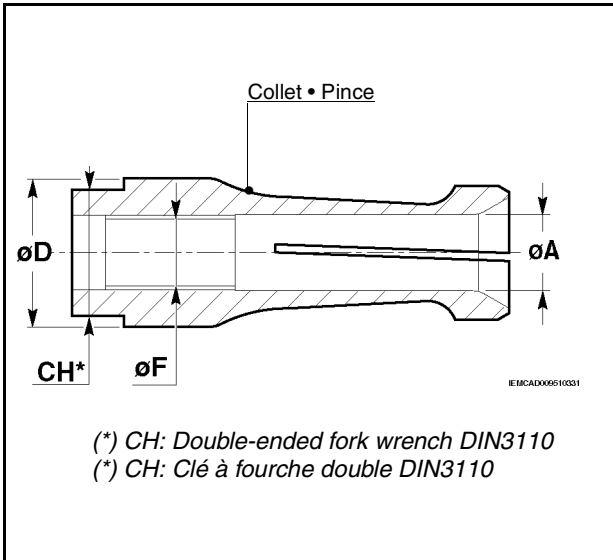

076 PINCES POUR BARRES - Tableau

PRECAUTION: le diamètre externe de la pince doit être inférieur d'au moins 0,5 mm au diamètre externe de la poussette.

Note pour la consultation

Les codes sur fond gris indiquent le "GROUPE D'UTILISATION" pour compléter un jeu de pinces quand l'usinage a lieu sur le guide-barre le plus important, et que l'enclenchement ϕF sur l'embout tournant est le même.

Remarque pour la commande

- Les pinces qui ont les codes en gras sont disponibles dans le magasin.
- Les pinces qui ont les codes en italique ont un délai de livraison plus long.

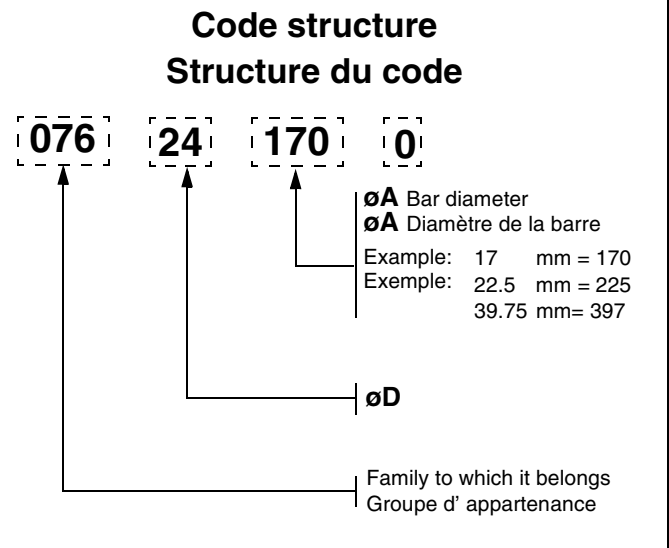

ϕA		ϕF M17x1 CH22	ϕF M17x1 CH22
mm	in	ϕD 24	ϕD 25
15	19/32"		
15.25			
15.5	39/64"		
15.75			
16	5/8"		
16.25	41/64"		
16.5		076241650	
16.75	21/32"	076241670	
17	43/64"	076241700	
17.25		076241720	

ϕA		ϕF M17x1 CH22	ϕF M17x1 CH22
mm	in	ϕD 24	ϕD 25
17.5	11/16"	076241750	
17.75		076241770	
18	45/64"		076251800
18.25	23/32"		076251820
18.5			076251850
18.75	47/64"		076251870
19	3/4"		076251900
19.25			076251920
19.5	49/64"		076251950

$\varnothing A$		$\varnothing F$ M17x1 CH22	$\varnothing F$ M17x1 CH24	$\varnothing F$ M17x1 CH27	$\varnothing F$ M17x1 CH27	$\varnothing F$ M25x1,5 CH29
<i>mm</i>	<i>in</i>	$\varnothing D$ 25	$\varnothing D$ 27	$\varnothing D$ 29	$\varnothing D$ 30	$\varnothing D$ 32
19.75	25/32"	076251970				
20		076252000	076272000			
20.25	51/64"	076252020	076272020			
20.5		076252050	076272050			
20.75	13/16"	076252070	076272070			
21	53/64"		076272100			
21.25			076272120			
21.5	27/32"		076272150			
21.75	55/64"		076272170			
22			076272200	076292200		
22.25	7/8"		076272220	076292220		
22.5			076272250	076292250		
22.75	57/64"		076272270	076292270		
23	29/32"		076272300	076292300		
23.25			076272320	076292320		
23.5	59/64"		076272350	076292350		
23.75			076272370	076292370		
24	15/16"		076272400		076302400	
24.25	61/64"		076272420		076302420	
24.5			076272450		076302450	
24.75	31/32"		076272470		076302470	
25	63/64"		076272500		076302500	076322500
25.25					076302520	076322520
25.5	1"				076302550	076322550
25.75					076302570	076322570
26					076302600	076322600
26.25					076302620	076322620
26.5					076302650	076322650
26.75					076302670	076322670
27					076302700	076322700

øA		øF M 25x1,5 CH29	øF M 25x1,5 CH32	øF M 25x1,5 CH32	øF M 25x1,5 CH32	øF M 25x1,5 CH36	øF M 25x1,5 CH36
<i>mm</i>	<i>in</i>	øD 32	øD 34	øD 35	øD 36-37	øD 38	øD 40
27	1"1/16	076322700	076342700				
27.25		076322720	076342720				
27.5		076322750	076342750				
27.75		076322770	076342770				
28		076322800	076342800				
28.25		076322820	076342820				
28.5	1"1/8	076322850	076342850				
28.75		076322870	076342870				
29		076322900		076352900			
29.25				076352920			
29.5				076352950			
29.75				076352970			
30				076353000			
30.25	1"3/16			076353020	076363020		
30.5				076353050	076363050		
30.75				076353070	076363070		
31				076353100	076373100	076383100	
31.25				076353120	076373120	076383120	
31.5				076353150	076373150	076383150	
31.75	1"1/4			076353170	076373170	076383170	
32				076353200	076373200	076383200	
32.25					076373220	076383220	
32.5					076373250	076383250	
32.75					076373270	076383270	
33					076373330		076403300
33.25	1"5/16				076373320		076403320
33.5					076373350		076403350
33.75					076373370		076403370
34					076373400		076403400
34.25					076373420		076403420
34.5					076373450		076403450
34.75					076373470		076403470
35	1"3/8				076373500		076403500

$\varnothing A$		$\varnothing F M 25 \times 1,5$ CH70	$\varnothing F M 25 \times 1,5$ CH70			
<i>mm</i>	<i>in</i>	$\varnothing D 74$	$\varnothing D 76$			
67.25		076746720				
67.5		076746750				
67.75		076746770				
68		076746800				
68.25	2"11/16	076746820				
68.5		076746850				
68.75		076746870				
69		076746900				
69.25			076766920			
69.5			076766950			
69.75			076766970			
70	2"3/4		076767000			

078 - 225

**RINGS FOR COLLETS
BAGUES POUR PINCES**

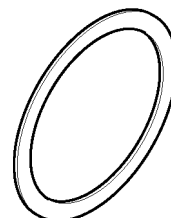

IDM-062.035Ec.0

078-225 RINGS FOR COLLETS - Table

078-225 BAGUES POUR PINCES - Tableau

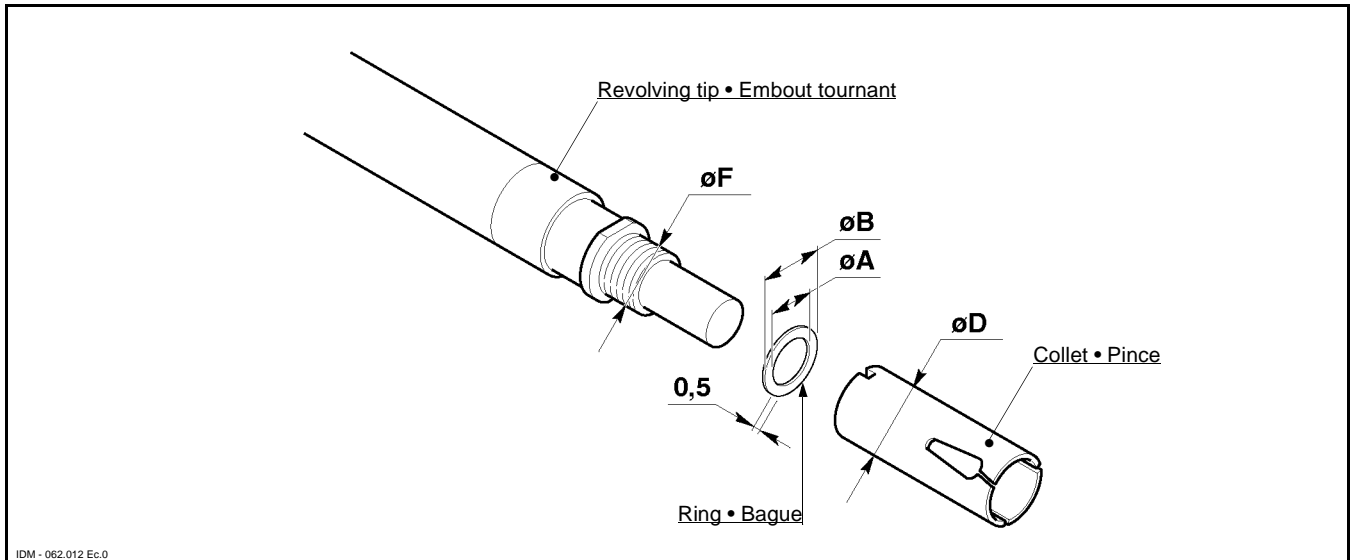

øA (mm)	øB (mm)	øD (mm)	øF	Code ring Code bague
8	14	16		22540008(.)
12	18	20		22540004(.)
12	25	25		078800220(.)
17	24	30	M17x1	22540026
17	30	35		078800200
25	30	30	M25x1.5	078800180
25	35	40		22540009
25	45	51		078800230

(*) Only for 316 collet(TAL)

(*) Uniquement pour pinces 316 (TAL)

336

**EJECTOR
ÉJECTEUR**

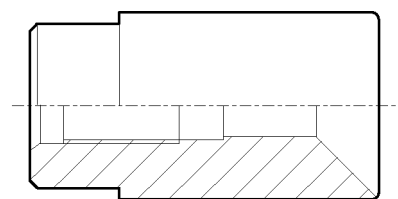

IDM-062.040 Ec.0

336 EJECTORS - GUIDES $\varnothing < 30$ - TABLE

336 ÉJECTEURS - GUIDES $\varnothing < 30$ - TABLEAU



CAUTION: the external diameter of the collet must be at least 0.5 mm less than the external diameter of the bar pusher.



PRECAUTION: le diamètre externe de l'éjecteur doit être inférieur d'au moins 0,5 mm au diamètre externe de la poussette.

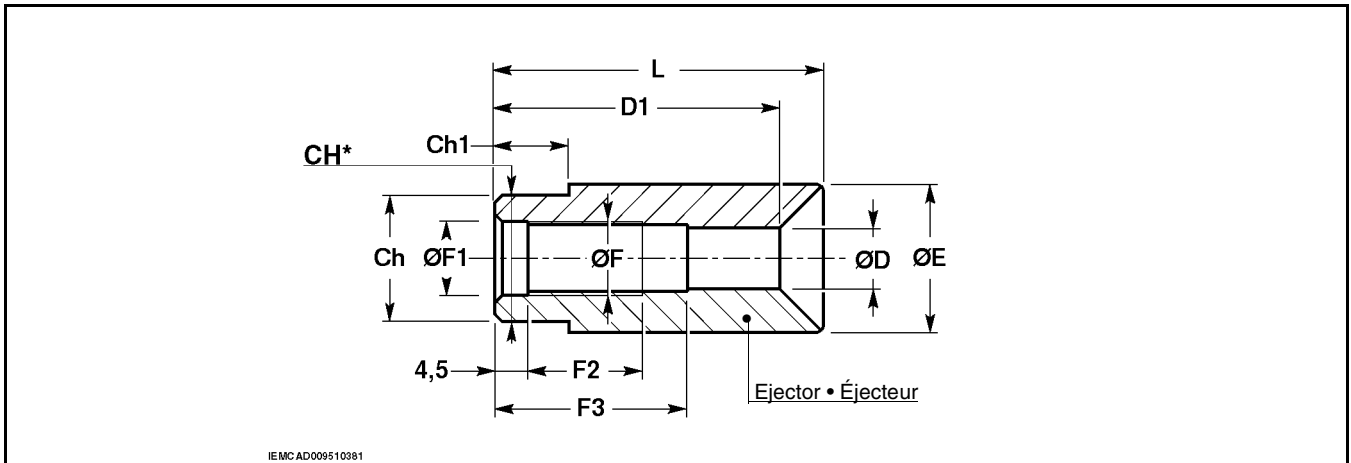

IEMCAD009510381

(*) CH: Double-ended fork wrench DIN 3110

(*)CH: Clé à fourche double DIN 3110

$\varnothing F$	F1 (mm)	F2 (mm)	F3 (mm)	$\varnothing E$ (mm)	L (mm)	$\varnothing D$ (mm)	D1 (mm)	Ch (mm)	Ch1 (mm)	N. code Numero code
M7x0.75	7	12	18	12	29.75	5.5	26.5	10	6	336803120
M8x1	8	12	18	15	30.75	6.5	26.5	13	10	336803150
M8x1	8	12	18	18	32	6.5	26.5	15	10	336803180
M10x1	10	15.5	26	20	44.4	8.2	38.5	17	10	336803200
M10x1	10	15.5	26	23	46	8.2	38.5	19	10	336803230
M10x1	10	15.5	26	25	47	8.2	38.5	22	12	336803250
M10x1	10	15.5	26	27	48	8.2	38.5	24	12	336803270
M10x1	10	15.5	26	29	49	8.2	38.5	27	12	336803290

336 EJECTORS - GUIDES $\varnothing > 32$ - TABLE

CAUTION: the external diameter of the collet must be at least 0.5 mm less than the external diameter of the bar pusher.

336 ÉJECTEURS - GUIDES $\varnothing > 32$ - TABLEAU

PRECAUTION: le diamètre externe de l'éjecteur doit être inférieur d'au moins 0,5 mm au diamètre externe de la poussette.

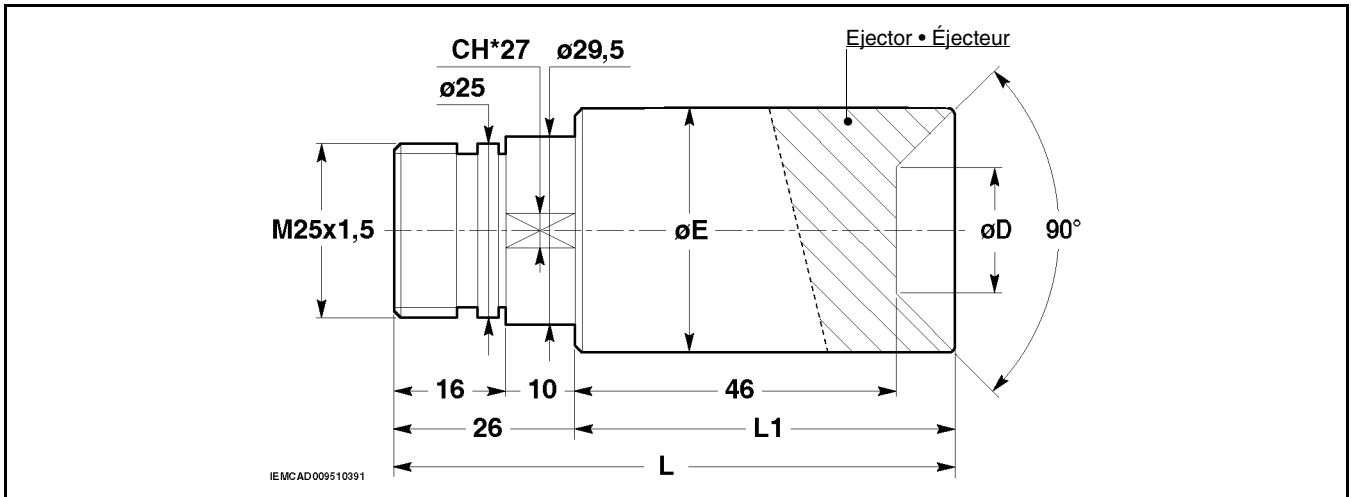

(*) CH: Double-ended fork wrench DIN 3110

(*)CH: Clé à fourche double DIN 3110

$\varnothing E$ (mm)	$\varnothing D$ (mm)	L (mm)	L1 (mm)	N. code Numero code
31	10	82.5	56.5	336803310
32	14	81	55	336803320
35	18	80.5	54.5	336803350
40	18	83	57	336803400
42	18	84	58	336803420
45	21	84	58	336803450
50	23	84	58	336803500

381P

**COLLETS FOR BARS
PINCES POUR BARRES**

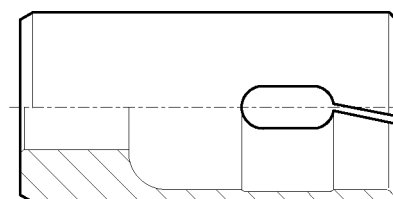

IDM-062.041 Ec.0

381P COLLETS FOR BARS - Table

CAUTION: the external diameter of the collet must be at least 0.5 mm less than the external diameter of the bar pusher.

Note for consultation

The Codes on a grey background refer to the "USE RANGE" to for complete a set of collets while working with the larger channel, and coupling ϕF on the revolving tip is the same.

Note for ordering

- Collets with codes in bold characters are available from stock.
- Collets with codes in italics have longer delivery times.

381P PINCES POUR BARRES - Tableau

PRECAUTION: le diamètre externe de la pince doit être inférieur d'au moins 0,5 mm au diamètre externe de la poussette.

Note pour la consultation

Les codes sur fond gris indiquent le "GROUPE D'UTILISATION" pour compléter un jeu de pinces quand l'usinage a lieu sur le guide-barre le plus important, et que l'enclenchement ϕF sur l'embout tournant est le même.

Remarque pour la commande

- Les pinces qui ont les codes en gras sont disponibles dans le magasin.
- Les pinces qui ont les codes en italique ont un délai de livraison plus long.

IEMCAD009510401

Code structure Structure du code

381	P	45	400
		<p>ϕA Bar diameter ϕA Diamètre de la barre</p> <p>Example: 40 mm = 400 Exemple: 39.75 mm = 397</p>	
		<p>ϕD</p> <p>Family to which it belongs Groupe d'appartenance</p>	

(*) CH4: Hexagonal T male wrench DIN911

(*) CH4: Clé mâle hexagonale à T DIN911

øA		øF ø20 G6					
<i>mm</i>	<i>in</i>	øD 32					
10	25/64"	381P32100					
10.25		381P32102					
10.5		381P32105					
10.75		381P32107					
11		381P32110					
11.25	7/16"	381P32112					
11.5	29/64"	381P32115					
11.75		381P32117					
12	15/32"	381P32120					
12.25		381P32122					
12.5	31/64"	381P32125					
12.75	1/2"	381P32127					
13		381P32130					
13.25	33/64"	381P32132					
13.5	17/32"	381P32135					
13.75		381P32137					
14	35/64"	381P32140					
14.25	9/16"	381P32142					
14.5		381P32145					
14.75	37/64"	381P32147					
15	19/32"	381P32150					
15.25		381P32152					
15.5	39/64	381P32155					
15.75		381P32157					
16	5/8"	381P32160					
16.25	41/64"	381P32162					
16.5		381P32165					
16.75	21/32"	381P32167					
17	43/64"	381P32170					
17.25		381P32172					
17.5	11/16"	381P32175					
17.75		381P32177					
18	45/64"	381P32180					
18.25	23/32"	381P32182					
18.5		381P32185					

øA		øF ø20 G6	øF ø20 G6				
<i>mm</i>	<i>in</i>	øD 32	øD 35				
18.75	47/64"	381P32187					
19	3/4"	381P32190					
19.25		381P32192					
19.5	19/64"	381P32195					
19.75	25/32"	381P32197					
20		381P32200					
20.25	51/64"	381P32202					
20.5		381P32205					
20.75	13/16"	381P32207					
21	53/64"	381P32210					
21.25		381P32212					
21.5	27/32"	381P32215					
21.75	55/64"	381P32217					
22		381P32220					
22.25	7/8"	381P32222					
22.5		381P32225					
22.75	57/64"	381P32227					
23	29/32"	381P32230					
23.25		381P32232					
23.5	59/64"	381P32235					
23.75		381P32237					
24	15/16"	381P32240					
24.25	61/64"	381P32242					
24.5		381P32245					
24.75	31/32"	381P32247					
25	63/64"	381P32250					
25.25		381P32252					
25.5	1"	381P32255					
25.75		381P32257					
26		381P32260					
26.25		381P32262					
26.5		381P32265					
26.75		381P32267					
27	1"1/16	<i>381P32270</i>	381P35270				
27.25		<i>381P32272</i>	381P35272				

øA		øF ø20 G6	øF ø20 G6	øF ø20 G6	øF ø20 G6	øF ø20 G6	
<i>mm</i>	<i>in</i>	øD 32	øD 35	øD 37	øD 40	øD 42	
27.5		381P32275	381P35275				
27.75		381P32277	381P35277				
28		381P32280	381P35280				
28.25		381P32282	381P35282				
28.5	1"1/8	381P32285	381P35285				
28.75		381P32287	381P35287				
29		381P32290	381P35290	381P37290			
29.25			381P35292	381P37292			
29.5			381P35295	381P37295			
29.75			381P35297	381P37297			
30			381P35300	381P37300	381P40300		
30.25	1"3/16		381P35302	381P37302	381P40302		
30.5			381P35305	381P37305	381P40305		
30.75			381P35307	381P37307	381P40307		
31			381P35310	381P37310	381P40310		
31.25			381P35312	381P37312	381P40312		
31.5			381P35315	381P37315	381P40315		
31.75	1"1/4		381P35317	381P37317	381P40317		
32			381P35320	381P37320	381P40320		
32.25				381P37322	381P40322		
32.5				381P37325	381P40325		
32.75				381P37327	381P40327		
33				381P37330	381P40330		
33.25	1"5/16			381P37332		381P42332	
33.5				381P37335		381P42335	
33.75				381P37337		381P42337	
34				381P37340		381P42340	

øA			øF ø20 G6	øF ø20 G6	øF ø20 G6		
<i>mm</i>	<i>in</i>		øD 42	øD 44	øD 45		
34.25			381P42342				
34.5			381P42345				
34.75			381P42347				
35	1"3/8		381P42350				
35.25			381P42352				
35.5			381P42355				
35.75			381P42357				
36			381P42360				
36.25	1"7/16		381P42362				
36.5			381P42365				
36.75			381P42367				
37			381P42370				
37.25			381P42372				
37.5			381P42375				
37.75			381P42377				
38	1"1/2		<i>381P42380</i>	381P44380			
38.25			<i>381P42382</i>	381P44382			
38.5			<i>381P42385</i>	381P44385			
38.75			<i>381P42387</i>	381P44387			
39			<i>381P42390</i>		381P45390		
39.25					381P45392		
39.5					381P45395		
39.75	1"9/16				381P45397		
40					<i>381P45400</i>		
40.25					<i>381P45402</i>		
40.5					<i>381P45405</i>		
40.75					<i>381P45407</i>		
41					<i>381P45410</i>		
41.25					<i>381P45412</i>		
41.5					<i>381P45415</i>		
41.75					<i>381P45417</i>		
42					<i>381P45420</i>		

øA		øF ø20 G6	øF ø20 G6	øF ø20 G6	øF ø20 G6	øF ø20 G6	
<i>mm</i>	<i>in</i>	øD 48	øD 49	øD 50-51	øD 52	øD 54	
40		381P48400					
40.25		381P48402					
40.5		381P48405					
40.75		381P48407					
41		381P48410					
41.25	1"5/8	381P48412					
41.5		381P48415					
41.75		381P48417					
42		381P48420					
42.25		381P48422					
42.5		381P48425					
42.75		381P48427					
43	1"11/16		381P49430				
43.25			381P49432				
43.5			381P49435				
43.75			381P49437				
44				381P50440			
44.25				381P50442			
44.5	1"3/4			381P50445			
44.75				381P50447			
45				<i>381P51450</i>	381P52450		
45.25				<i>381P51452</i>	381P52452		
45.5				<i>381P51455</i>	381P52455		
45.75				<i>381P51457</i>	381P52457		
46	1"13/16			<i>381P51460</i>	381P52460		
46.25				<i>381P51462</i>	381P52462		
46.5				<i>381P51465</i>	381P52465		
46.75				<i>381P51467</i>	381P52467		
47				<i>381P51470</i>	381P52470		
47.25					381P52472		
47.5					381P52475		
47.75	1"7/8				381P52477		
48						381P54480	

øA		øF ø20 G6	øF ø20 G6	øF ø20 G6	øF ø20 G6	øF ø20 G6	
<i>mm</i>	<i>in</i>	øD 54	øD 56	øD 58	øD 59	øD 60	
48.25		381P54482					
48.5		381P54485					
48.75		381P54487					
49		381P54490					
49.25	1"15/16	381P54492					
49.5		381P54495					
49.75		381P54497					
50			381P56500				
50.25			381P56502				
50.5			381P56505				
50.75	2"		381P56507				
51			<i>381P56510</i>	381P58510			
51.25			<i>381P56512</i>	381P58512			
51.5			<i>381P56515</i>	381P58515			
51.75			<i>381P56517</i>	381P58517			
52			<i>381P56520</i>	381P58520			
52.25				381P58522			
52.5	2"1/16			381P58525			
52.75				381P58527			
53					381P59530		
53.25					381P59532		
53.5					381P59535		
53.75					381P59537		
54	2"1/8					381P60540	
54.25						381P60542	
54.5						381P60545	
54.75						381P60547	
55						381P60550	
55.25						381P60552	
55.5	2"3/16					381P60555	
55.75						381P60557	

øA		øF ø20 G6	øF ø20 G6	øF ø20 G6	øF ø20 G6	øF ø20 G6	øF ø20 G6
<i>mm</i>	<i>in</i>	øD 70	øD 72	øD 74-75	øD 76	øD 78	øD 80
64		381P70640					
64.25		381P70642					
64.5		381P70645					
64.75		381P70647					
65	2"9/16	381P70650					
65.25		<i>381P70652</i>	381P72652				
65.5		<i>381P70655</i>	381P72655				
65.75		<i>381P70657</i>	381P72657				
66			381P72660				
66.25			381P72662				
66.5			381P72665				
66.75	2"5/8		381P72667				
67			381P72670				
67.25				381P74672			
67.5				381P74675			
67.75				381P74677			
68				381P74680			
68.25	2"11/16			381P74682			
68.5				381P74685			
68.75				381P74687			
69				<i>381P74690</i>	381P76690		
69.25				<i>381P74692</i>	381P76692		
69.5				<i>381P75695</i>	381P76695		
69.75				<i>381P74697</i>	381P76697		
70	2"3/4			<i>381P75700</i>	381P76700		
70.25						381P78702	
70.5						381P78705	
70.75						381P78707	
71						381P78710	
71.25						381P78712	
71.5	2"13/16					381P78715	
71.75						381P78717	
72						<i>381P78720</i>	381P80720

øA		øF ø20 G6	øF ø20 G6				
<i>mm</i>	<i>in</i>	øD 80	øD 85				
72.25		381P80722					
72.5		381P80725					
72.75		381P80727					
73	2"7/8	381P80730					
73.25		381P80725					
73.5		381P80735					
73.75		381P80737					
74		<i>381P80740</i>	381P85740				
74.25			381P85742				
74.5	2"15/16	<i>381P80745</i>	381P85745				
74.75			381P85747				
75		<i>381P80750</i>	381P85750				
75.25			381P85752				
75.5			381P85755				
75.75			381P85757				
76			381P85760				
76.25	3"		381P85762				
76.5			381P85765				
76.75			381P85767				
77			381P85770				
77.25			381P85772				
77.5			381P85775				
77.75			381P85777				
78			381P85780				
78.25			381P85782				
78.5			381P85785				
78.75			381P85787				
79			381P85790				
79.25			381P85792				
79.5			381P85795				
79.75			381P85797				
80			381P85800				

381P..011

381P..021

EJECTOR
ÉJECTEUR

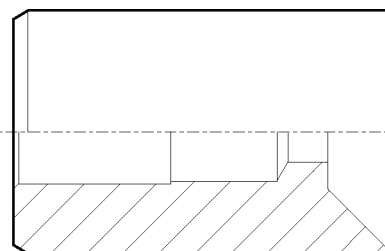

IDM - 062.073 Ec.0

381P..011 EJECTORS - GUIDES Ø52÷86 - TABLE

CAUTION: the external diameter of the collet must be at least 0.5 mm less than the external diameter of the bar pusher.

381P..011 ÉJECTEURS - GUIDES Ø52÷86 - TABLEAU

PRECAUTION: le diamètre externe de l'éjecteur doit être inférieur d'au moins 0,5 mm au diamètre externe de la poussette.

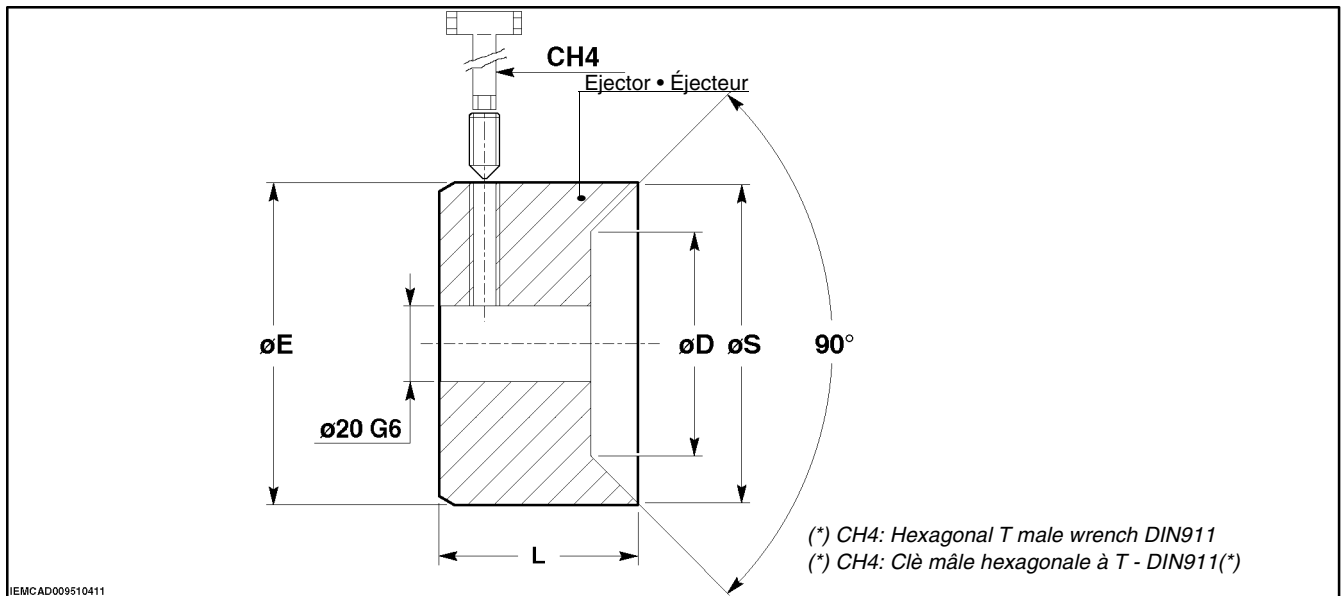

øE (mm)	L (mm)	øS (mm)	øD (mm)	N. code Numero code
51	52.5	50	25	381P51011
56	52.5	55	30	381P56011
60	52.5	59	34	381P60011
65	52.5	64	39	381P65011
68	52.5	67	42	381P68011
70	52.5	69	44	381P70011
72	52.5	71	46	381P72011
75	52.5	74	50	381P75011
80	52.5	79	55	381P80011
85	52.5	84	60	381P85011

381P..021 EJECTORS - GUIDES Ø33÷52 - TABLE

CAUTION: the external diameter of the collet must be at least 0.5 mm less than the external diameter of the bar pusher.

381P..021 ÉJECTEURS - GUIDES Ø33÷52 - TABLEAU

PRECAUTION: le diamètre externe de l'éjecteur doit être inférieur d'au moins 0,5 mm au diamètre externe de la poussette.

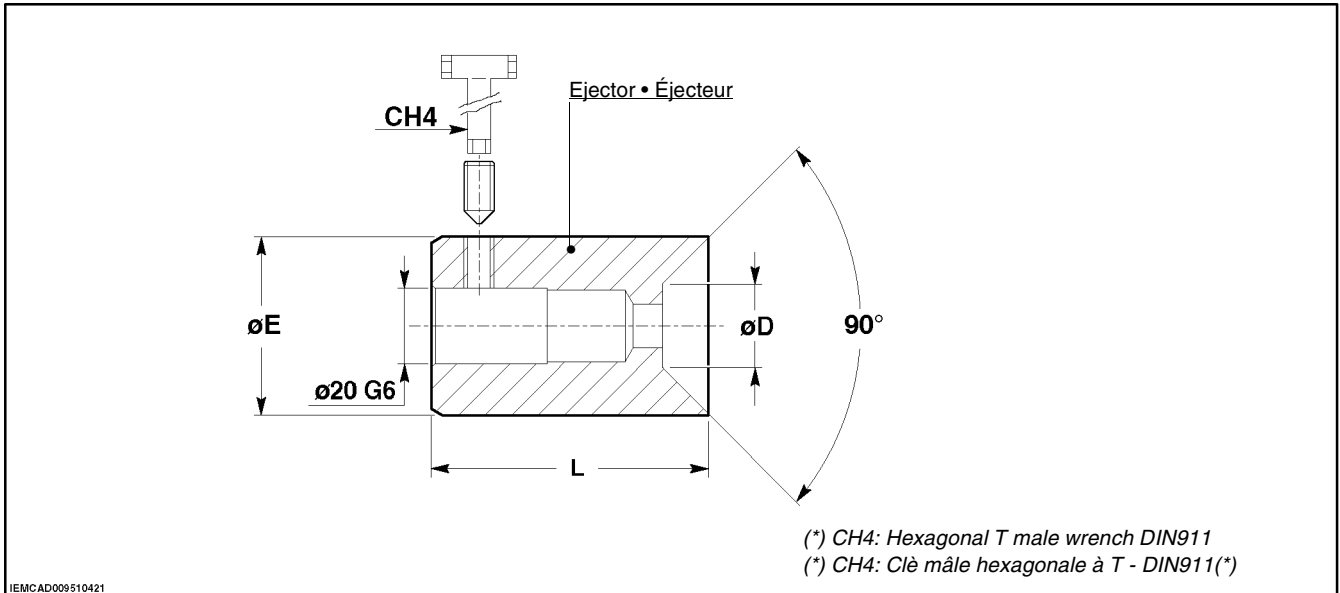

øE (mm)	øD (mm)	L (mm)	N. code Numero code
30	12	69	381P30021
31	13	70	381P31021
32	14	71	381P32021
35	18	69	381P35021
37	18	70	381P37021
40	18	71.5	381P40021
42	18	72.5	381P42021
45	21	72.5	381P45021
51	25	73.5	381P51021

386P

COLLETS FOR TUBES
PINCES POUR TUBES

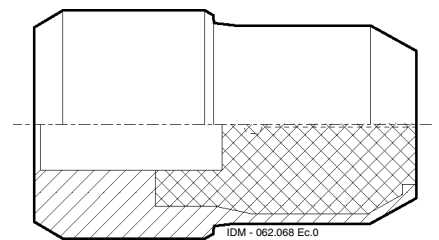

386P COLLETS FOR TUBES - Table

CAUTION: the external diameter of the collet must be at least 0.5 mm less than the external diameter of the bar pusher.

Note for consultation

The Codes on a grey background refer to the "USE RANGE" to for complete a set of collets while working with the larger channel, and coupling ϕF on the revolving tip is the same.

Note for ordering

- Collets with codes in bold characters are available from stock.
- Collets with codes in italics have longer delivery times.

386P PINCES POUR TUBES - Tableau

PRECAUTION: le diamètre externe de la pince doit être inférieur d'au moins 0,5 mm au diamètre externe de la poussette.

Note pour la consultation

Les codes sur fond gris indiquent le "GROUPE D'UTILISATION" pour compléter un jeu de pinces quand l'usinage a lieu sur le guide-barre le plus important, et que l'enclenchement ϕF sur l'embout tournant est le même.

Remarque pour la commande

- Les pinces qui ont les codes en gras sont disponibles dans le magasin.
- Les pinces qui ont les codes en italique ont un délai de livraison plus long.

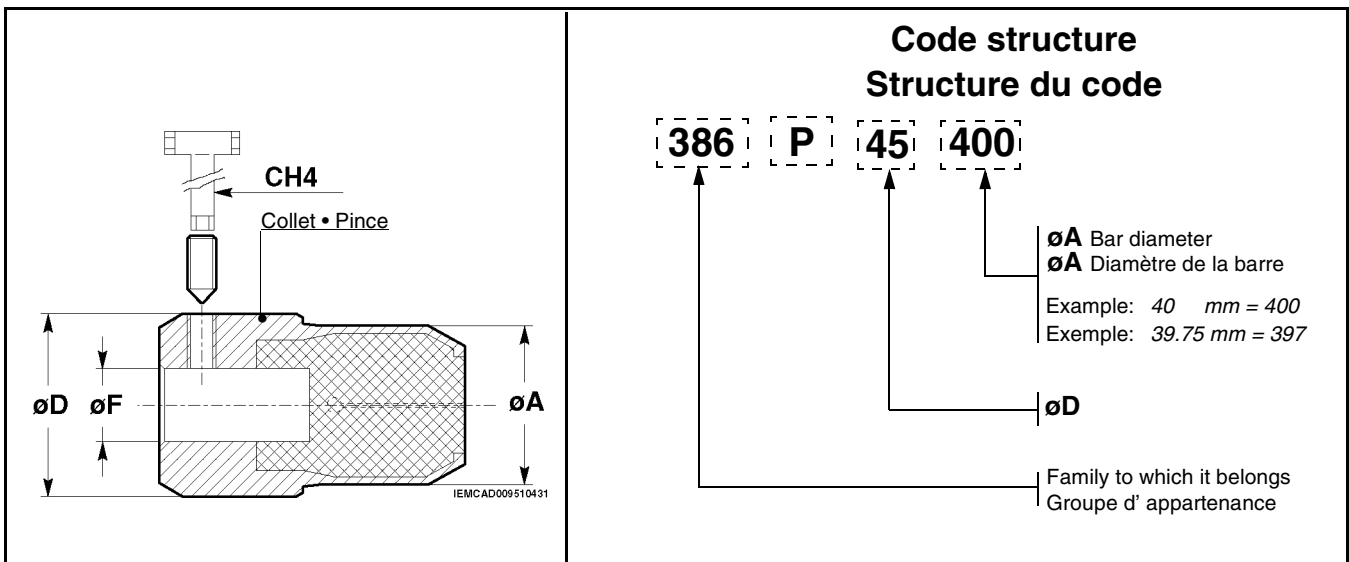

(*) CH4: Hexagonal T male wrench DIN911

(*)CH4: Clé mâle hexagonale à T - DIN911

ϕA		ϕF 20G6	ϕA		ϕF 20G6	ϕA		ϕF 20G6
mm	in	ϕD 40	mm	in	ϕD 40	mm	in	ϕD 40
25		386P40250	28.5		<i>386P40285</i>	32		386P40320
25.25		<i>386P40252</i>	28.75		<i>386P40287</i>	32.25		<i>386P40322</i>
25.5		<i>386P40255</i>	29		386P40290	32.5		<i>386P40325</i>
25.75		<i>386P40257</i>	29.25		<i>386P40292</i>	32.75		<i>386P40327</i>
26		386P40260	29.5		<i>386P40295</i>	33		386P40330
26.25		<i>386P40262</i>	29.75		<i>386P40297</i>	33.25		<i>386P40332</i>
26.5		<i>386P40265</i>	30		386P40300	33.5		<i>386P40335</i>
26.75		<i>386P40267</i>	30.25		<i>386P40302</i>	33.75		<i>386P40337</i>
27		386P40270	30.5		<i>386P40305</i>	34		386P40340
27.25		<i>386P40272</i>	30.75		<i>386P40307</i>	34.25		<i>386P40342</i>
27.5		<i>386P40275</i>	31		386P40310	34.5		<i>386P40345</i>
27.75		<i>386P40277</i>	31.25		<i>386P40312</i>	34.75		<i>386P40347</i>
28		386P40280	31.5		<i>386P40315</i>			
28.25		<i>386P40282</i>	31.75		<i>386P40317</i>			

øA		øF 20G6	øF 20G6	øF 20G6	øF 20G6	øF 20G6	
<i>mm</i>	<i>in</i>	øD 41	øD 44	øD 45	øD 49	øD 50	
35		386P41350					
35.25		386P41352					
35.5		386P41355					
35.75		386P41357					
36		386P41360					
36.25		386P41362					
36.5		386P41365					
36.75		386P41367					
37		386P41370					
37.25			386P44372				
37.5			386P44375				
37.75			386P44377				
38			386P44380				
38.25			386P44382				
38.5			386P44385				
38.75			386P44387				
39			386P44390				
39.25			386P44392				
39.5			386P44395				
39.75			386P44397				
40			386P44400				
40.25				386P45402			
40.5				386P45405			
40.75				386P45407			
41				386P45410			
41.25				386P45412			
41.5				386P45415			
41.75				386P45417			
42				386P45420			
42.25					386P49422		
42.5					386P49425		
42.75					386P49427		
43					386P49430		
43.25					386P49432		
43.5					386P49435		
43.75					386P49437		
44					386P49440		
44.25					386P49442		
44.5					386P49445		
44.75					386P49447		
45					386P49450		
45.25						386P50452	
45.5						386P50455	
45.75						386P50457	
46						386P50460	
46.25						386P50462	
46.5						386P50465	
46.75						386P50467	

øA		øF 20G6	øF 20G6	øF 20G6	øF 20G6	øF 20G6	
<i>mm</i>	<i>in</i>	øD 54	øD 56	øD 59	øD 60	øD 64	
47		386P54470					
47.25		386P54472					
47.5		386P54475					
47.75		386P54477					
48		386P54480					
48.25		386P54482					
48.5		386P54485					
48.75		386P54487					
49			386P56490				
49.25			386P56492				
49.5			386P56495				
49.75			386P56497				
50			386P56500				
50.25			386P56502				
50.5			386P56505				
50.75			386P56507				
51			386P56510				
51.25			386P56512				
51.5			386P56515				
51.75			386P56517				
52			386P56520				
52.25			386P56522				
52.5				386P59525			
52.75				386P59527			
53				386P59530			
53.25				386P59532			
53.5				386P59535			
53.75				386P59537			
54				386P59540			
54.25				386P59542			
54.5				386P59545			
54.75				386P59547			
55					386P60550		
55.25					386P60552		
55.5					386P60555		
55.75					386P60557		
56					386P60560		
56.25					386P60562		
56.5					386P60565		
56.75					386P60567		
57						386P64570	
57.25						386P64572	
57.5						386P64575	
57.75						386P64577	
58						386P64580	
58.25						386P64582	
58.5						386P64585	
58.75						386P64587	

øA		øF 20G6	øF 20G6	øF 20G6	øF 20G6	øF 20G6	
<i>mm</i>	<i>in</i>	øD 65	øD 68	øD 70	øD 71	øD 75	
59		386P65590					
59.25		386P65592					
59.5		386P65595					
59.75		386P65597					
60		386P65600					
60.25		386P65602					
60.5		386P65605					
60.75		386P65607					
61			386P68610				
61.25			386P68612				
61.5			386P68615				
61.75			386P68617				
62			386P68620				
62.25			386P68622				
62.5			386P68625				
62.75			386P68627				
63			386P68630				
63.25			386P68632				
63.5			386P68635				
63.75			386P68637				
64				386P70640			
64.25				386P70642			
64.5				386P70645			
64.75				386P70647			
65				386P70650			
65.25				386P70652			
65.5				386P70655			
65.75				386P70657			
66					386P71660		
66.25					386P71662		
66.5					386P71665		
66.75					386P71667		
67						386P75670	
67.25						386P75672	
67.5						386P75675	
67.75						386P75677	
68						386P75680	
68.25						386P75682	
68.5						386P75685	
68.75						386P75687	
69						386P75690	
69.25						386P75692	
69.5						386P75695	
69.75						386P75697	

øA		øF 20G6	øF 20G6
<i>mm</i>	<i>in</i>	øD 80	øD 85
70		386P80700	
70.25		<i>386P80702</i>	
70.5		<i>386P80705</i>	
70.75		<i>386P80707</i>	
71		386P80710	
71.25		<i>386P80712</i>	
71.5		<i>386P80715</i>	
71.75		<i>386P80717</i>	
72		386P80720	
72.25		<i>386P80722</i>	
72.5		<i>386P80725</i>	
72.75		<i>386P80727</i>	
73		386P80730	
73.25		<i>386P80732</i>	
73.5		<i>386P80735</i>	
73.75		<i>386P80737</i>	
74		386P80740	
74.25			<i>386P85742</i>
74.5			<i>386P85745</i>
74.75			<i>386P85747</i>
75			386P85750
75.25			<i>386P85752</i>
75.5			<i>386P85755</i>
75.75			<i>386P85757</i>
76			386P85760
76.25			
76.5			
76.75			
77			
77.25			
77.5			
77.75			
78			
78.25			
78.5			
78.75			
79			
79.25			
79.5			
79.75			
80			



601P

**“UNILOCK” COLLETS FOR BARS
PINCES “UNILOCK” POUR CARRÉES**

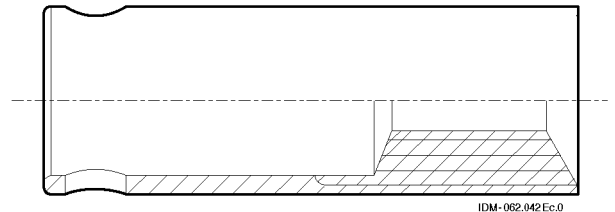

IDM-062.042Ec.0

601P “UNILOCK” COLLETS FOR SQUARE BARS - Table

601P PINCES “UNILOCK” POUR BARRES CARRÉES - Tableau

i **INFORMATION:** for defining the internal diameter ϕA do not consult “001 - Conversion Tables” document, but directly consult the table below.

i **AVERTISSEMENT:** pour définir le diamètre interne ϕA ne pas consulter le fascicule “001 - Tableaux de conversion”, mais consulter directement le tableau suivant.

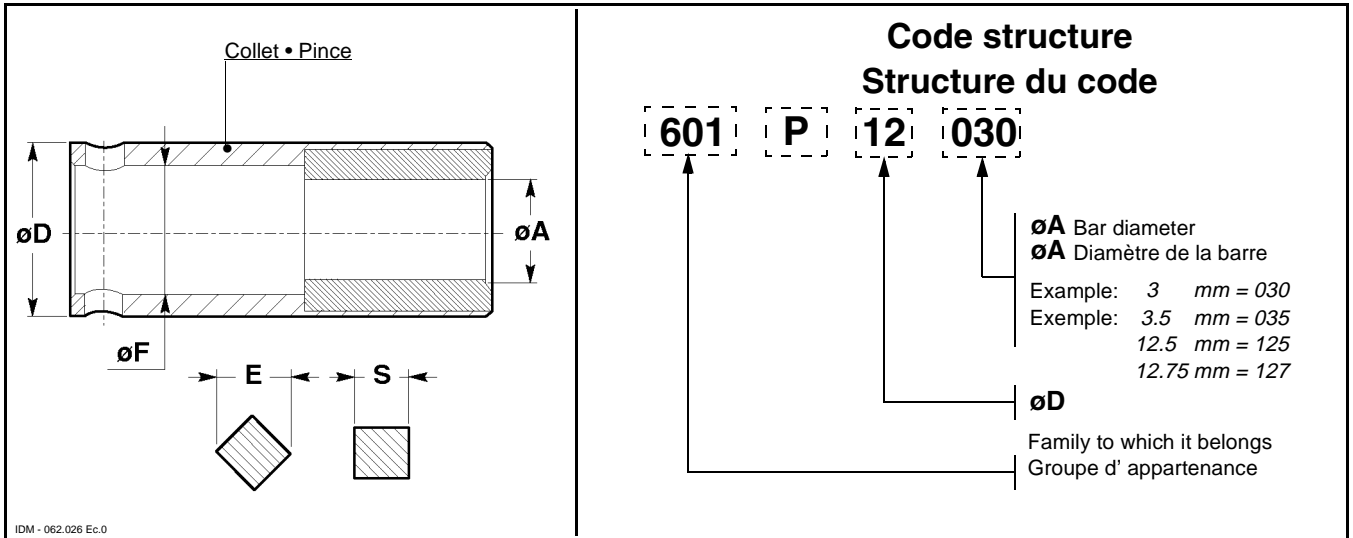

S	E E=Sx1.414	ϕA ^{+0.1} 0	ϕF M5x0.5	ϕF $\phi 8$ G6	ϕF $\phi 11$ G6	ϕF $\phi 14$ G6	ϕF $\phi 20$ G6
mm	mm	mm	ϕD 7.5	ϕD 12	ϕD 18	ϕD 21	ϕD 25
3	4.24	3.8	601P08038				
4	5.65	5.1		601P12051			
5	7.07	6.6		601P12066			
6	8.48	8		601P12080	601P18080		
7	9.90	9.2			601P18092	601P21092	
8	11.31	10.3			601P18103	601P21103	
9	12.73	11.7			601P18117	601P21117	
10	14.14	13.1			601P18131	601P21131	601P25131
11	15.55	14.5				601P21145	601P25145
12	16.97	15				601P21150	601P25150

S	E E=Sx1.414	øA ^{+0.1} 0	øF M5x0.5	øF ø8 G6	øF ø11 G6	øF ø14 G6
<i>mm</i>	<i>mm</i>	<i>mm</i>	øD 25	øD 29	øD 32	øD 36
13	18.38	17.4	601P25174			
14	19.80	18.8	601P25188			
15	21.21	20.2	601P25202			
16	22.62	21.6		601P29216		
17	24.04	23		601P29230		
18	25.45	24.5			601P32245	
19	26.87	25.9			601P32259	
20	28.28	27.3			601P32273	
21	29.69	28.7				601P36287
22	31.11	30.1				601P36301
23	32.52	31.5				601P36315

601P “UNILOCK” COLLETS FOR HEXAGONAL BARS - Table

i **INFORMATION:** for defining the internal diameter ϕA do not consult “001 - Conversion Tables” document, but directly consult the table below.

Note for consultation

The Codes on a grey background refer to the “USE RANGE” to for complete a set of collets while working with the larger channel, and coupling ϕF on the revolving tip is the same.

Note for ordering

- Collets with codes in bold characters are available from stock.
- Collets with codes in italics have longer delivery times.

601P PINCES “UNILOCK” POUR BARRES HEXAGONALES - Tableau

i **AVERTISSEMENT:** pour définir le diamètre interne ϕA ne pas consulter le fascicule “001 - Tableaux de conversion”, mais consulter directement le tableau suivant.

Note pour la consultation

Les codes sur fond gris indiquent le “GROUPE D'UTILISATION” pour compléter un jeu de pinces quand l'usinage a lieu sur le guide-barre le plus important, et que l'enclenchement ϕF sur l'embout tournant est le même.

Remarque pour la commande

- Les pinces qui ont les codes en gras sont disponibles dans le magasin.
- Les pinces qui ont les codes en italique ont un délai de livraison plus long.

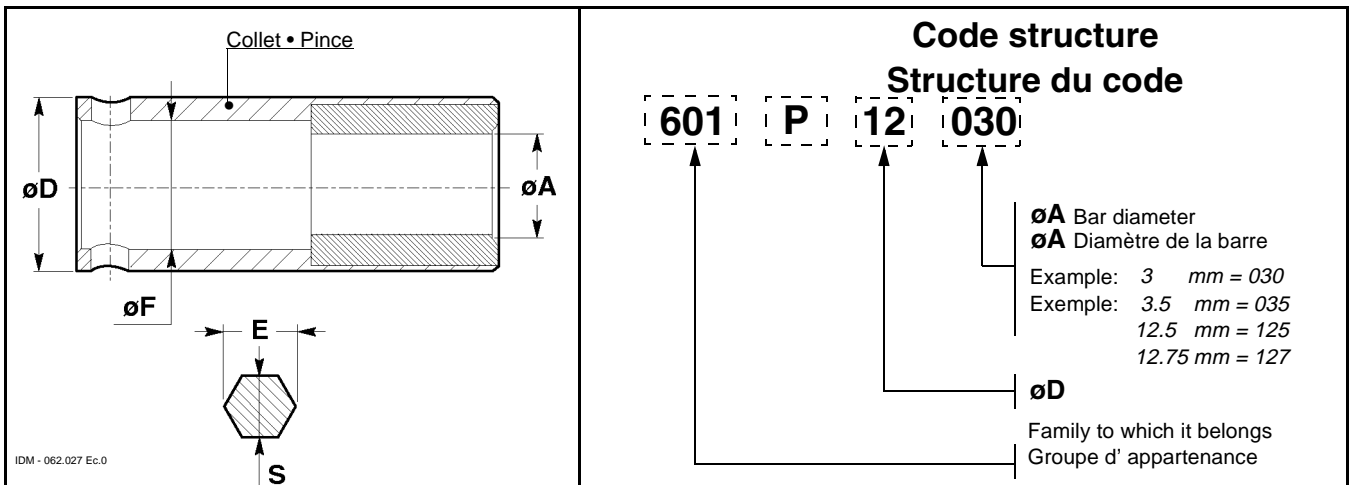

S		E	ϕA	ϕF	ϕF	ϕF	ϕF	ϕF
E= SX1.154		$^{+0.1}_0$	M5 x0.5	$\phi 8$ G6	$\phi 11$ G6	$\phi 14$ G6	$\phi 20$ G6	
mm	in	mm	ϕD 7.5	ϕD 12	ϕD 18	ϕD 21	ϕD 25	
3		3.46	3.1	601P08031				
	1/8"	3.66	3.3	601P08033				
4		4.62	4.1	601P08041				
	3/16"	5.5	5		601P12050			
5		5.77	5.2		601P12052			
6		6.92	6.2		601P12062			
	1/4"	7.33	6.6		601P12066	<i>601P18066</i>		
7		8.08	7.3		<i>601P12073</i>	601P18073		
	5/16"	9.16	8.3			601P18083	601P21083	
8		9.23	8.4			601P18084	601P21084	
9		10.39	9.5			601P18095	601P21095	
	3/8"	10.99	10			601P18100	601P21100	
10		11.54	10.6			601P18106	601P21106	
11		12.7	11.7			601P18117	601P21117	
	7/16"	12.82	11.8			601P18118	601P21118	
12		13.85	12.8			601P18128	601P21128	601P25128

S		E E=SX1.154	øA ^{+0.1} ₀	øF 14 G6	øF 20 G6	øF 20 G6	øF 20 G6	øF 20 G6
<i>mm</i>	<i>in</i>	<i>mm</i>	<i>mm</i>	øD 21	øD 25	øD 29	øD 32	øD 36
	1/2"	14.65	13.7	601P21137	601P25137			
13		15	14	601P2140	601P25140			
14		16.16	15.2	601P21152	601P25152			
	9/16"	16.49	15.5	601P21155	601P25155			
15		17.31	16.3	601P21163	601P25163			
	5/8"	18.32	17.3		601P25173			
16		18.46	17.5		601P25175			
17		19.62	18.6		601P25186			
	11/16"	20.15	19.2		601P25192	<i>601P29192</i>		
18		20.77	19.8		601P25198	<i>601P29198</i>		
19	3/4"	21.93	21			601P29210		
20		23.08	22.1			601P29221		
	13/16"	23.81	22.8			601P29228		
21		24.24	23.2			601P29232	<i>601P32232</i>	
22		25.39	24.4				601P32244	
	7/8"	25.65	24.7				601P32247	
23		26.54	25.5				601P32255	
	15/16"	27.48	26.5				601P32265	
24		27.7	26.7				601P32267	<i>601P36267</i>
25		28.85	27.9					601P36279
	1"	29.31	28.3					601P36283
26		30	29					601P36290
	1-1/16"	31.14	30.2					601P36302
28		32.31	31.3					601P36313

602P

**COLLETS FOR BARS
PINCES POUR BARRES**

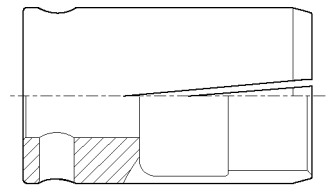

602P COLLETS FOR BARS - Table
602P PINCES POUR BARRES - Tableau

CAUTION: the external diameter of the collet must be at least 0.5 mm less than the external diameter of the bar pusher.



PRECAUTION: le diamètre externe de la pince doit être inférieur d'au moins 0,5 mm au diamètre externe de la poussette.

Note for consultation

The Codes on a grey background refer to the "USE RANGE" to for complete a set of collets while working with the larger channel, and coupling ϕF on the revolving tip is the same.

Note pour la consultation

Les codes sur fond gris indiquent le "GROUPE D'UTILISATION" pour compléter un jeu de pinces quand l'usinage a lieu sur le guide-barre le plus important, et que l'enclenchement ϕF sur l'embout tournant est le même.

Note for ordering

- Collets with codes in bold characters are available from stock.
- Collets with codes in italics have longer delivery times.

Remarque pour la commande

- Les pinces qui ont les codes en gras sont disponibles dans le magasin.
- Les pinces qui ont les codes en italique ont un délai de livraison plus long.

Collet • Pince

Code structure

Structure du code

602
P
12
030

ϕA Bar diameter
 ϕA Diamètre de la barre
 Example: 3 mm = 030
 Exemple: 3.5 mm = 035
 12.5 mm = 125
 12.75 mm = 127

ϕD
 Family to which it belongs
 Groupe d'appartenance

ϕA		$\phi F \phi 8 G6$	$\phi F \phi 11 G6$			
mm	in	$\phi D 12$	$\phi D 15$			
3		602P12030				
3.1		602P12031				
3.2	1/8"	602P12032				
3.3		602P12033				
3.4		602P12034				
3.5		602P12035				
3.6	9/64"	602P12036				
3.7		602P12037				
3.8		602P12038				
3.9		602P12039				
4	5/32"	602P12040	<i>602P15040</i>			
4.1		602P12041	<i>602P15041</i>			
4.2		602P12042	<i>602P15042</i>			
4.3		602P12043	<i>602P15043</i>			
4.4	11/64"	602P12044	<i>602P15044</i>			
4.5		602P12045	<i>602P15045</i>			
4.6		602P12046	<i>602P15046</i>			
4.7		602P12047	<i>602P15047</i>			
4.8	3/16"	602P12048	<i>602P15048</i>			
4.9		602P12049	<i>602P15049</i>			
5		602P12050	602P15050			
5.1		602P12051	602P15051			

DM - 062.028 Ec.0

øA		øF ø8 G6	øF ø11 G6	øF ø14 G6	øF ø20 G6		
<i>mm</i>	<i>in</i>	øD 12	øD 15	øD 20	øD 25		
5.2	13/64"	602P12052	602P15052				
5.3		602P12053	602P15053				
5.4		602P12054	602P15054				
5.5		602P12055	602P15055				
5.6	7/32"	602P12056	602P15056				
5.7		602P12057	602P15057				
5.8		602P12058	602P15058				
5.9		602P12059	602P15059				
6	15/64"	602P12060	602P15060				
6.1		602P12061	602P15061				
6.2		602P12062	602P15062				
6.3		602P12063	602P15063				
6.4	1/4"	602P12064	602P15064				
6.5		602P12065	602P15065				
6.6		602P12066	602P15066				
6.7		602P12067	602P15067				
6.8	17/64"	602P12068	602P15068				
6.9		602P12069	602P15069				
7		602P12070	602P15070				
7.1		602P12071	602P15071				
7.2	9/32"	602P12072	602P15072				
7.3		602P12073	602P15073				
7.4		602P12074	602P15074				
7.5		602P12075	602P15075				
7.6	19/64"	602P12076	602P15076				
7.7		602P12077	602P15077				
7.8		602P12078	602P15078				
7.9		602P12079	602P15079				
8	5/16"	602P12080	602P15080	602P20080	602P25080		
8.1		602P12081	602P15081	602P20081	602P25081		
8.2		602P12082	602P15082	602P20082	602P25082		
8.3		602P12083	602P15083	602P20083	602P25083		
8.4	21/64"	602P12084	602P15084	602P20084	602P25084		
8.5		602P12085	602P15085	602P20085	602P25085		
8.6		602P12086	602P15086	602P20086	602P25086		
8.7		602P12087	602P15087	602P20087	602P25087		
8.8	11/32"	602P12088	602P15088	602P20088	602P25088		
8.9		602P12089	602P15089	602P20089	602P25089		
9		602P12090	602P15090	602P20090	602P25090		
9.1	23/64"	602P12091	602P15091	602P20091	602P25091		
9.2		602P12092	602P15092	602P20092	602P25092		

øA		øF ø8 G6	øF ø11 G6	øF ø11 G6	øF ø11 G6	øF ø14 G6	øF ø20 G6
<i>mm</i>	<i>in</i>	øD 12	øD 15	øD 16	øD 18	øD 20	øD 25
9.3		602P12093	602P15093			602P20093	602P25093
9.4		602P12094	602P15094			602P20094	602P25094
9.5		602P12095	602P15095			602P20095	602P25095
9.6	3/8"	602P12096	602P15096			602P20096	602P25096
9.7		602P12097	602P15097			602P20097	602P25097
9.8		602P12098	602P15098			602P20098	602P25098
9.9		602P12099	602P15099			602P20099	602P25099
10	25/64"	602P12100	602P15100			602P20100	602P25100
10.1			602P15101			602P20101	602P25101
10.2			602P15102			602P20102	602P25102
10.3			602P15103			602P20103	602P25103
10.4	13/32"		602P15104			602P20104	602P25104
10.5			602P15105			602P20105	602P25105
10.6			602P15106			602P20106	602P25106
10.7			602P15107			602P20107	602P25107
10.8	27/64"		602P15108			602P20108	602P25108
10.9			602P15109			602P20109	602P25109
11			602P15110	602P16110		602P20110	602P25110
11.25	7/16"		602P15112	602P16112		602P20112	602P25112
11.5	29/64"		602P15115	602P16115		602P20115	602P25115
11.75			602P15117	602P16117		602P20117	602P25117
12	15/32"		602P15120	602P16120		602P20120	602P25120
12.25			602P15122	602P16122		602P20122	602P25122
12.5	31/64"		602P15125	602P16125	602P18125	602P20125	602P25125
12.75	1/2"		602P15127	602P16127	602P18127	602P20127	602P25127
13			602P15130	602P16130	602P18130	602P20130	602P25130
13.25	33/64"			602P16132	602P18132	602P20132	602P25132
13.5	17/32"			602P16135	602P18135	602P20135	602P25135
13.75				602P16137	602P18137	602P20137	602P25137
14	35/64"			602P16140	602P18140	602P20140	602P25140
14.25	9/16"				602P18142	602P20142	602P25142
14.5					602P18145	602P20145	602P25145
14.75	37/64"				602P18147	602P20147	602P25147
15	19/32"				602P18150	602P20150	602P25150
15.25					602P18152	602P20152	602P25152
15.5	39/64"				602P18155	602P20155	602P25155
15.75					602P18157	602P20157	602P25157

øA		øF ø11 G6	øF ø14 G6	øF ø14 G6	øF ø14 G6	øF ø20 G6	øF ø20 G6
<i>mm</i>	<i>in</i>	øD 18	øD 20	øD 21	øD 23	øD 25	øD 27
16	5/8"	602P18160	602P20160		<i>602P23160</i>	602P25160	
16.25	41/64"		602P20162		<i>602P23162</i>	602P25162	
16.5			<i>602P20165</i>	602P21165	602P23165	602P25165	
16.75	21/32"		<i>602P20167</i>	602P21167	602P23167	602P25167	
17	43/64"		<i>602P20170</i>	602P21170	602P23170	602P25170	
17.25			<i>602P20172</i>	602P21172	602P23172	602P25172	
17.5	11/16"		<i>602P20175</i>	602P21175	602P23175	602P25175	
17.75			<i>602P20177</i>	602P21177	602P23177	602P25177	
18	45/64"		<i>602P20180</i>	602P21180	602P23180	602P25180	
18.25	23/32"			602P21182	602P23182	602P25182	
18.5				602P21185	602P23185	602P25185	
18.75	47/64"			602P21187	602P23187	602P25187	
19	3/4"			602P21190	602P23190	602P25190	
19.25					602P23192	602P25192	
19.5	49/64"				602P23195	602P25195	
19.75	25/32"				602P23197	602P25197	
20					602P23200	602P25200	
20.25	51/64"				602P23202	602P25202	
20.5					602P23205	602P25205	
20.75	13/16"				602P23207	602P25207	
21	53/64"				602P23210	<i>602P25210</i>	602P27210
21.25						<i>602P25212</i>	602P27212
21.5	27/32"					<i>602P25215</i>	602P27215
21.75	55/64"					<i>602P25217</i>	602P27217

øA		øF ø20 G6	øF ø20 G6	øF ø20 G6	øF ø20 G6	øF ø20 G6	øF ø20 G6
<i>mm</i>	<i>in</i>	øD 25	øD 27	øD 29	øD 32	øD 35	øD 36
22		602P25222	602P27222				
22.25	7/8"	602P25225	602P27225				
22.5		602P25220	602P27220				
22.75	57/64"	602P25227	602P27227	602P29227			
23	29/32"	602P25230	602P27230	602P29230			
23.25			602P27232	602P29232			
23.5	59/64"		602P27235	602P29235			
23.75			602P27237	602P29237			
24	15/16"		602P27240	602P29240			
24.25	61/64"		602P27242	602P29242			
24.5			602P27245	602P29245			
24.75	31/32"		602P27247	602P29247			
25	63/64"		602P27250	602P29250	602P32250		
25.25				602P29252	602P32252		
25.5	1"			602P29255	602P32255		
25.75				602P29257	602P32257		
26				602P29260	602P32260		
26.25				602P29262	602P32262		
26.5				602P29265	602P32265		
26.75				602P29267	602P32267		
27	1"1/16			602P29270	602P32270	602P35270	
27.25					602P32272	602P35272	
27.5					602P32275	602P35275	
27.75					602P32277	602P35277	
28					602P32280	602P35280	602P36280
28.25					602P32282	602P35282	602P36282
28.5	1"1/8				602P32285	602P35285	602P36285
28.75					602P32287	602P35287	602P36287

øA		øF ø20 G6	øF ø20 G6	øF ø20 G6	øF ø20 G6	øF ø20 G6	
<i>mm</i>	<i>in</i>	øD 32	øD 35	øD 36	øD 42	øD 45	
29		602P32290	602P35290	602P36290			
29.25		602P32292	602P35292	602P36292			
29.5		602P32295	602P35295	602P36295			
29.75		602P32297	602P35297	602P36297			
30		602P32300	602P35300	602P36300			
30.25	1"3/16		602P35302	602P36302			
30.5			602P35305	602P36305			
30.75			602P35307	602P36307			
31			602P35310	602P36310	602P42310		
31.25			602P35312	602P36312	602P42312		
31.5			602P35315	602P36315	602P42315		
31.75	1"1/4		602P35317	602P36317	602P42317		
32			602P35320	602P36320	602P42320		
32.25				602P36322	602P42322		
32.5				602P36325	602P42325		
32.75				602P36327	602P42327		
33				602P36330	602P42330		
33.25	1"5/16			602P36332	602P42332		
33.5				602P36335	602P42335		
33.75				602P36337	602P42337		
34				602P36340	602P42340		
34.25					602P42342		
34.5					602P42345		
34.75					602P42347		
35	1"3/8				602P42350		
35.25					602P42352		
35.5					602P42355		
35.75					602P42357		
36					602P42360		
36.25	1"7/16				602P42362		
36.5					602P42365		
36.75					602P42367		
37					602P42370	602P45370	
37.25					602P42372	602P45372	
37.5					602P42375	602P45375	
37.75					602P42377	602P45377	

øA		øF ø20 G6	øF ø20 G6	øF ø20 G6			
<i>mm</i>	<i>in</i>	øD 42	øD 45	øD 51			
38		602P42380	602P45380				
38.25		602P42382	602P45382				
38.5		602P42385	602P45385				
38.75		602P42387	602P45387				
39		602P42390	602P45390				
39.25		602P42392	602P45392				
39.5		602P42395	602P45395				
39.75		602P42397	602P45397	602P51397			
40		602P42400	602P45400	602P51400			
40.25			602P45402	602P51402			
40.5			602P45405	602P51405			
40.75			602P45407	602P51407			
41			602P45410	602P51410			
41.25			602P45412	602P51412			
41.5			602P45415	602P51415			
41.75			602P45417	602P51417			
42			602P45420	602P51420			
42.25				602P51422			
42.5				602P51425			
42.75				602P51427			
43	1"11/16			602P51430			
43.25				602P51432			
43.5				602P51435			
43.75				602P51437			
44				602P51440			
44.25				602P51442			
44.5				602P51445			
44.75				602P51447			
45				602P51450			
45.25				602P51452			
45.5				602P51455			
45.75				602P51457			
46				602P51460			
46.25				602P51462			
46.5				602P51465			
46.75				602P51467			
47				602P51470			

602P..011

EJECTOR
ÉJECTEUR

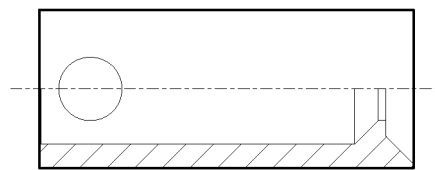

IDM - 062.076 Ec.0

602P..011 EJECTORS - GUIDES Ø13÷28 - TABLE

 **CAUTION:** the external diameter of the collet must be at least 0.5 mm less than the external diameter of the bar pusher.

602P..011 ÉJECTEURS - GUIDES Ø13÷28 - TABLEAU

 **PRECAUTION:** le diamètre externe de l'éjecteur doit être inférieur d'au moins 0,5 mm au diamètre externe de la poussette.

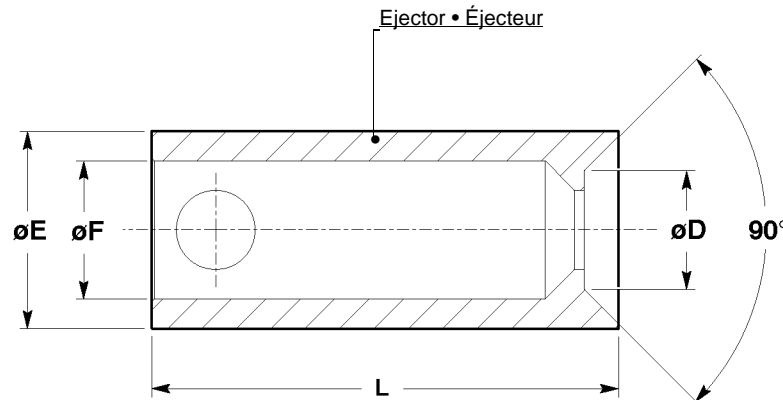

IDM-062.075Ec.0

øE (mm)	øF (mm)	øD (mm)	øL (mm)	N. code Numero code
12	8	8	24	602P12011
15	11	11	26	602P15011
16	11	12	26	602P16011
18	11	12	27.5	602P18011
19	11	12	28	602P19011
20	14	12	47.5	602P20011
23	14	12	49	602P23011
25	20	12	50.5	602P25011
27	20	12	51.5	602P27011

