

# NC Rotary Table

## INSTRUCTION MANUAL

### Model: MR250RAE14



## **DANGER**


- This instruction manual is for production engineers and maintenance personnel in charge of operation of this product. When a beginner uses this product, receive instructions from experienced personnel, the distributor or our company.
- Before installing, operating or maintaining this equipment, carefully read this manual and the safety labels attached to the equipment. Failure to follow these instructions and safety precautions could result in serious injury, death, or property damage.
- Store this manual near equipment for future reference.
- If any questions related to safety arise about this manual, please confirm them with the distributor or our company.

Thank you for choosing the Kitagawa NC Rotary Table.

Kitagawa, a world-renowned precision equipment manufacturer, has developed the finest quality NC Rotary Table with emphasis in high precision and rigidity as its basic principals in design.

This unit is installed on the machining centers and suitable for indexing the angle of machining position of the workpieces. Please contact us if it is used for any other applications.

This NC Rotary Table has been designed to provide years of high precision performance. To ensure optimum and trouble-free performance, please read this operation manual carefully before using the unit and retain this copy for your future reference.

Please pay close attention to the procedures with the following warning marks  to avoid severe injury and/or accident.

## **Safety Alert Symbol**

This is the industry “ Safety Alert Symbol ”. This symbol is used to call your attention to items or operations that could be dangerous to you or other persons using this equipment. Please read these messages and follow these instructions carefully. It is essential that you read the instructions and safety regulations before you attempt to assemble or use this unit.



**Indicates an Imminently hazardous situation which, if not avoided, will result in death or serious injury.**



**Indicates a potentially hazardous situation which, if not avoided, could result in death or serious injury.**



**Indicates a potentially hazardous situation which, if not avoided, may result in minor or moderate injury.**



**Instructions for table performance and avoiding errors or mistakes.**

## EC DECLARATION OF CONFORMITY

We hereby declare that the following our product conforms with the essential health and safety requirements of EC Directives.

Product : NC ROTARY TABLE

Type : MR Series, MRT Series ,GT Series, MX Series,  
TMX Series, THX Series, TRX Series, TLX Series,  
TBX Series, TUX Series, TR Series, TL Series,  
TP Series, LR Series TM Series, TH Series,  
TT Series, TW Series, DM Series

Directives : Machinery Directive 2006/42/EC  
EMC Directive 2004/108/EC

The above product has been evaluated for conformity with above directives using the following European standards.

Machinery Directive:

EN ISO 12100-1:2003+A1:2009, EN ISO 12100-2:2003+A1:2009,  
EN ISO 14121-1:2007, EN 60204-1: 2006+A1:2009, others

EMC Directive:

Emission : EN 55011+A2:2007  
Immunity : EN 61000-6-2:2005

---

## CONTENTS

---

	Page
1. For Your Safety .....	1
2. Specifications .....	8
3. Accuracies .....	10
4. Preparation .....	11
4-1. Installation	
4-2. Lubrication	
4-3. Required Oil Quantity	
4-4. Recommended Lubricating Oil	
4-5. Safety of Oil and Antirust Oil Used for the Unit	
5. Inspection .....	14
6. Use of NC Rotary Table .....	14
7. Table Clamp and Unclamp .....	15
7-1. General Instruction	
7-2. Inlet Pressure for Table Clamp	
7-3. Air purge	
7-4. Confirmation of Clamp and Unclamp	
7-5. Solenoid Valve for Clamp and Unclamp	
8. Mounting the Workpiece .....	18
9. Maintenance Work .....	19
9-1. Corrective Action in Case of Failure, and Disassembly	
9-2. Before Performing Maintenance Work	
10. Adjustment of Backlash between Worm Wheel and Worm Gear .....	20
10-1. Measuring the Backlash of the Worm Gear	
10-2. Adjusting the Backlash of the Worm Gear	
11. ZRN device .....	25
11-1. ZRN device on table	
11-2. ZRN device Adjustment	
11-3. Sensor Mechanism	
12. Motor Cover .....	27
12-1. Dismount	
12-2. Waterproofing	
13. Troubleshooting .....	29
14. Parts List .....	32
15. Storage .....	38

	Page
16. Disposal of NC Rotary Table .....	38
17. Indexing Accuracy and Pitch Error .....	39
18. Mounting Rotary Joint (Option) .....	40
18-1. Alignment of discharge opening face	
18-2. Pining to supply part	

#### Appendixes

- Appendix 1 Outside View
- Appendix 2 Wiring Diagram
- Appendix 3 Details of Nameplate


# 1. For Your Safety

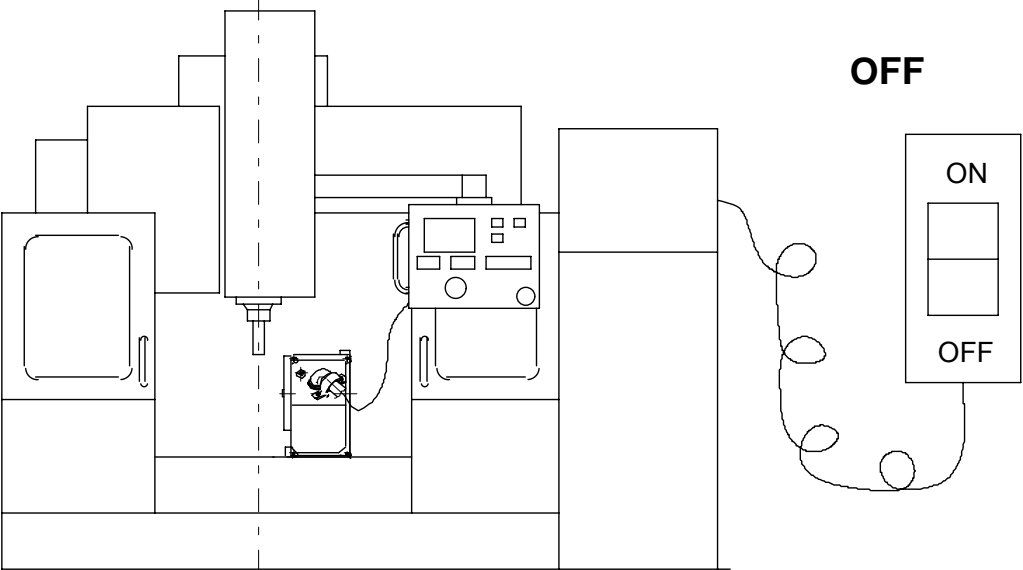
## Basic Safety Tips

Please read this manual and follow instructions carefully.

We cannot assume responsibility for damage or accidents caused by misuse of the NC Rotary indexing tables, through non-compliance with the safety instructions.



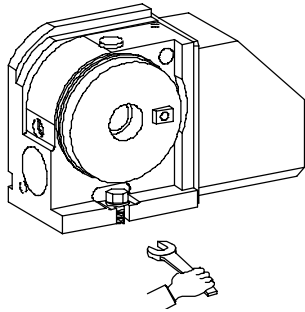
 Turn off the main power of the machine prior to maintenance, check, or repair of the unit, Failure to do so may cause severe injury and/or accident.



The diagram shows a side view of a machine with a control panel on the right. A power cord is connected to a switch labeled "OFF" above it. The switch has "ON" and "OFF" positions. The machine has a vertical spindle and a control console with a screen and buttons.



Tighten the bolts securely when mounting the unit on the machine table.

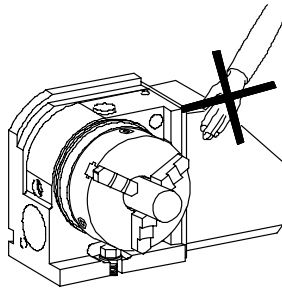


Please refer to the chart below for the recommended tightening torque of the bolts.

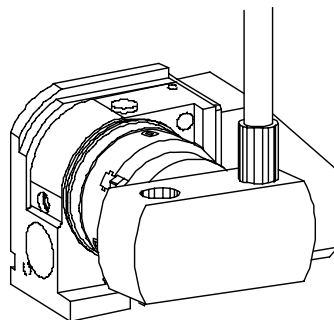
Hex. Bolt Size	Torque N·m
M10	33.8
M12	58.9
M16	146.3
M20	294.3



Make sure the working area is clear of any foreign object and/or hand when the unit is in operation to avoid any serious accident and/or injury.

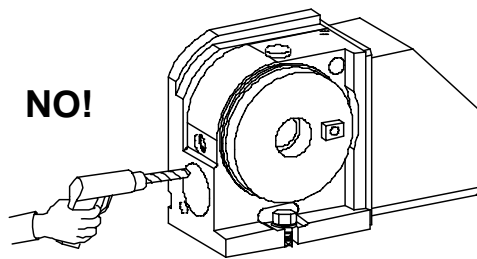


Do not apply cutting force which exceeds the specification in this manual. Failure to do so may cause severe injury and/or damage to the unit.



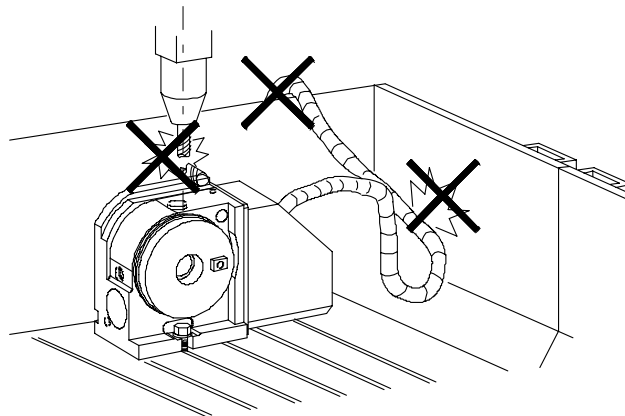


Please consult your local distributor before attempting any modification of the unit.



Maintain adequate clearance between the unit and any part of the machine.

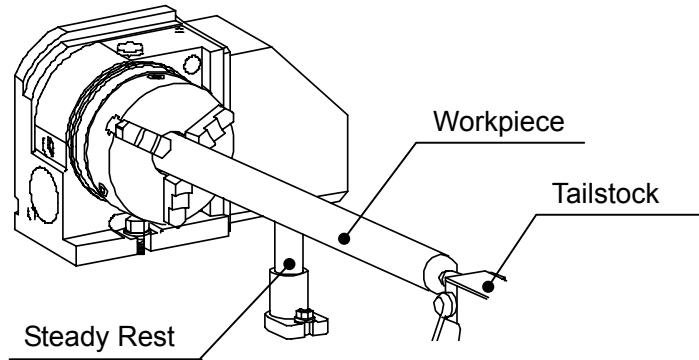
Avoid bending the external cables and air tube of the unit.





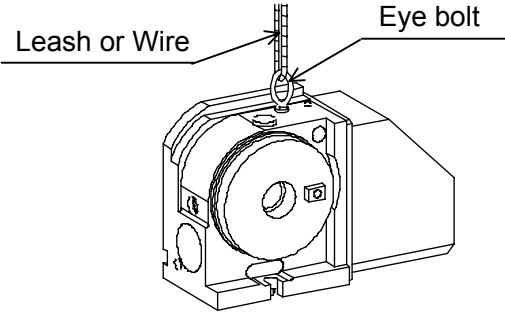


Use a support, steady rest, or tailstock for heavy or long workpieces to prevent any injury and/or accident.

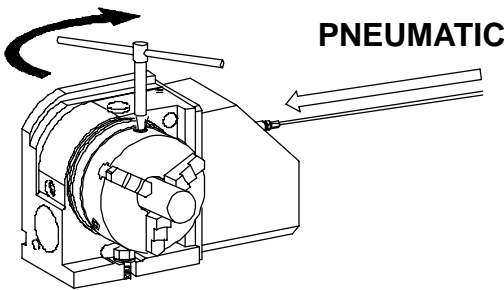




When transporting the unit, make sure to use eye bolts and a sufficient leash or wire.

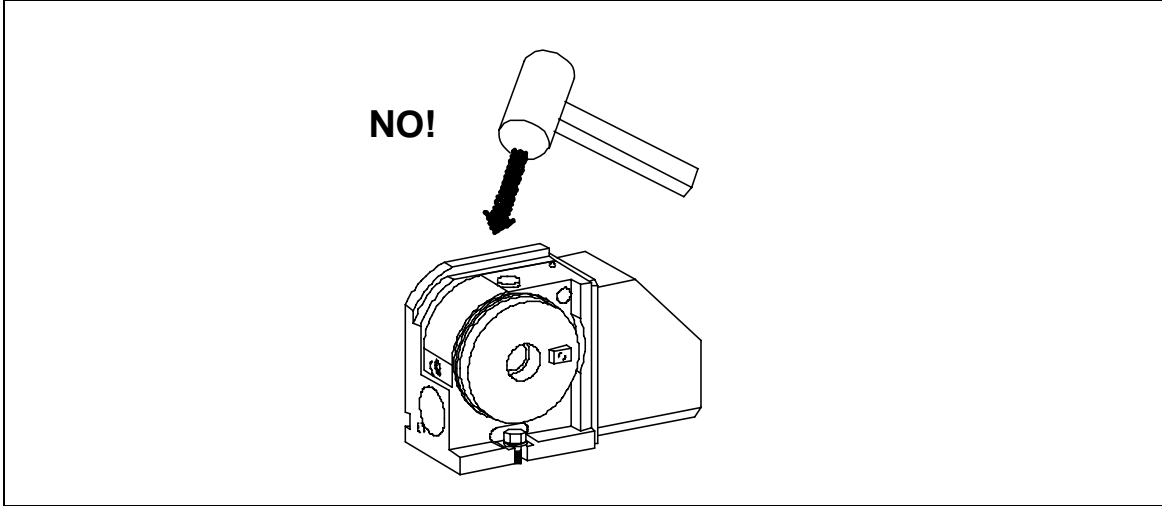


Mount or dismount the workpiece to or from the unit while the unit is clamped to avoid damage to the internal mechanism and diminished indexing accuracy of the unit.



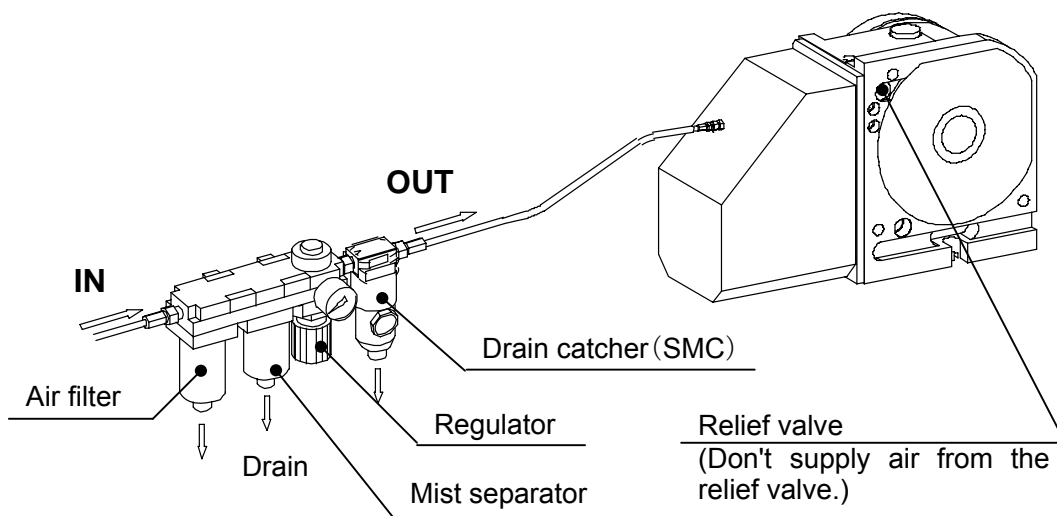


Avoid sudden impact to any part of the unit which may cause damage to the internal mechanism.



Supply air through Air combination (Air filter, Mist separator, regulator) + Drain catcher. (The air supply port is on the motor case.)

Apply air purge inside the motor case and be sure to provide dry air.

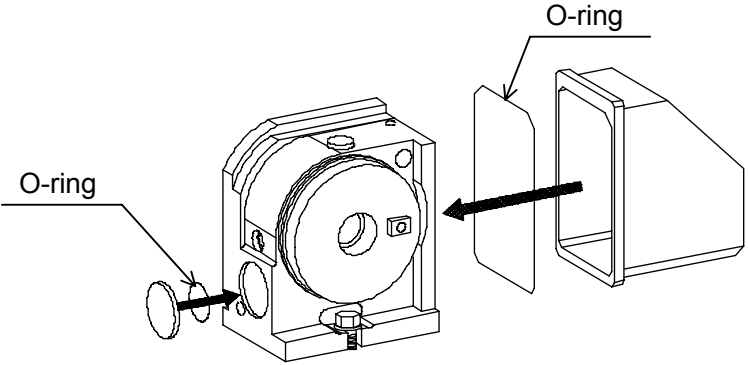


Periodically drain the water in air filter. (It is recommended to use the auto drain type.)

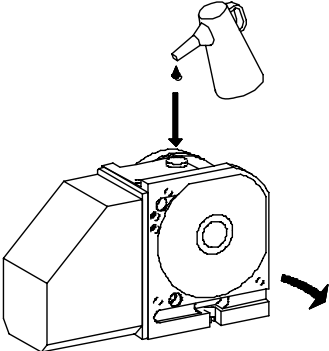
# NOTICE



Mount all covers attached with O-rings. (No damages on O-rings)



Replace lubricating oil every 6 months.



## 2. Specifications

NC Rotary Table is dividing unit for the workpiece, usually operating machines.

[ Machining Center, (NC) milling machine, (NC) drilling machine, etc. ]

Specifications are as below.

ITEM	MODEL		MR(M)	MR(M)	MR(M)	MR(M)	MR(M)	MX(M)
			120	160	200	250	320	160
1	Table Diameter	mm	φ 128	φ 165	φ 202	φ 250	φ 320	φ 165
2	Table Height in Horizontal	mm	136	145	173	180	210	150
3	Center Height in Vertical	mm	120	140	140	180	225	140
4	Center Hole Diameter	mm	φ 50	φ 50	φ 65	φ 100	φ 130	φ 50
5	Thru. Hole Diameter	mm	φ 32	φ 40	φ 45	φ 70	φ 106	φ 40
6	Guide Block Width	mm	10h7	14h7	14h7	14h7	14h7	14h7
7	Clamping Torque [Pneumatics 0.5MPa]	N·m	150	310	350	600	1200	310
8	Allowable Workpiece Dia.	mm	φ 128	φ 165	φ 200	φ 250	φ 320	φ 165
9	Allowable Mass of Workpiece	(Horizontal) kg	120	160	200	250	350	80
		(Vertical) kg	60	80	100	125	180	40
10	Allowable Work Inertia	kg·m <sup>2</sup>	0.22	0.51	1.00	1.95	4.49	0.25
11	Total Reduction Ratio		1/60	1/72	1/90	1/90	1/120	1/40
12	Max. Rotation Speed (M signal specification)	min <sup>-1</sup>	50	41.6	33.3	33.3	25 (16.6)	75
13	Mass of Rotary Table	kg	33	41	61	85	135	43
14	Operating temperature range	°C	5~40					
15	Operating humidity range	%	30~95					
16	Operating altitude range (above sea level)	m	1000 or lower					
17	Storage temperature range	°C	-10~60					
18	Environmental pollution degree		Degree 3					
19	Noise level	dB	79					

※The noise level is measured at a distance of 1m from the NC rotary table in front, rear, left, and right four positions of the unit.

※When storing the unit, conduct the antirust treatment and store it in a place free from wetting, condensation, or freeze.

## NOTICE

The above-mentioned list shows the value in standard specification. Please refer to the outside view for details.

## NOTICE

Table clamping torque is measured at 0.5MPa pneumatic pressure. Max. Rotation Speed is at 3000 min<sup>-1</sup>(rpm) of the motor rotation.

(In the case of MRM320: 2000 min<sup>-1</sup>(rpm))



## CAUTION

Be sure to observe the allowance work inertia even if the mass of workpiece is within the allowable value.



## CAUTION

There is any case that the tailstock is required by the mass of workpiece, shape, cutting conditions, etc.



## CAUTION

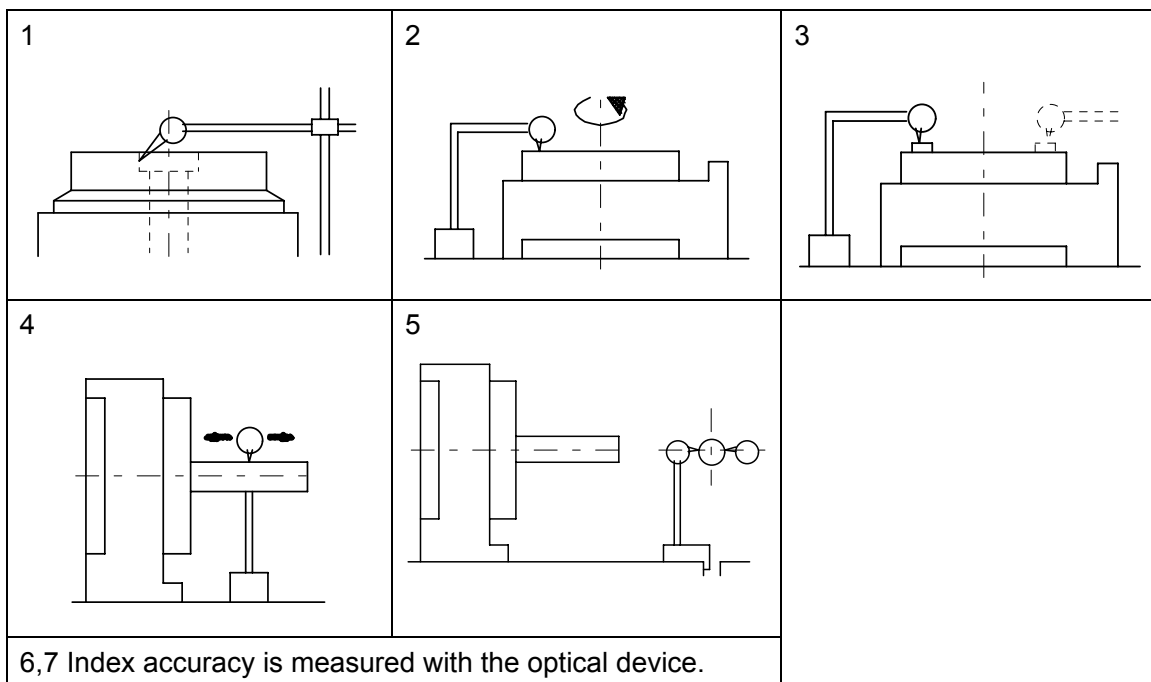
For the conditions for using the table, refer to the above specification columns and caution items. Set each cutting condition so as not to exceed the allowance value.

### 3. Accuracies

#### Guaranteed Accuracies

(Unit:mm)

	Description of Inspection		Guaranteed Accuracy
1	Run-out of center hole		0.01
2	Run-out of table surface		0.02
3	Parallelism of table surface and reference plane for horizontal installation	Per 150mm	0.02
4	Parallelism of rotating axis center line and reference plane for vertical installation	Per 150mm	0.02
5	Parallelism of rotating axis center line and guide block center	Per 150mm	0.02
6	Indexing accuracy	Cumulative	20 sec [MX(M):40 sec]
7	Repeatability	Cumulative	4 sec [MX(M):8 sec]



## 4. Preparation

Unpack the unit and remove the packing material.

### 4-1. Installation

- 1) When transporting the unit, hook ropes to the eyebolts attached and transport the unit carefully, not giving a shock. The ropes used should be wire ropes having enough strength to lift up the unit.
- 2) Clean the unit thoroughly with an adequate clean agent. When installing the unit on the machine table, make sure there is no foreign material nor damage such as nicks and burrs on the mating faces. Use an oil stone for correction if necessary.
- 3) The motor case may be removed depending on the maintenance work. Accordingly, whenever possible, install the NC rotary table in a position where the motor case can be removed. In case of vertical installation, the guide blocks will fit into the slotted groove on the machine. If there is any play between the guide block and the T-slot, place the unit against one side of the T-slot to eliminate the gap.
- 4) Firmly clamp down the unit to the machine with the furnished clamping fixtures.



Do not enter a part of your body under the NC rotary table during transportation.

Unexpected accidents such as a disengagement of lifting devices may cause the NC rotary table to drop on your body.



Apply the clamping fixtures to the step of the unit provided, and clamp the bolts with the specified torque.



The transport and lifting devices must be operated only by the qualified persons for respective devices.

Operating the transport devices by an unqualified person causes the NC rotary table or machine to be damaged due to an operation error, resulting in accidents.



When transporting a pallet on which NC rotary table is mounted, take measures against over-turning or drop.

Transporting the pallet with NC rotary table mounted



unstably may cause the NC rotary table to overturn and then to drop from the pallet.



Disconnect electric cables and working fluid piping when relocating the NC rotary table.

Relocating the NC rotary table with electric cables and working fluid piping connected and hung down causes the NC rotary table to be unstable or the worker to be tripped, resulting in unexpected accidents.

Electric cables or working fluid piping may be damaged during relocation, and if the NC rotary table is installed on the machine again, unexpected accidents may occur.

If electric cables and working fluid piping cannot be disconnected, secure them to the NC rotary table.



When the unit is installed on the machine, ensure to avoid any interferences with any part of the machine. Especially when the machine has a capability of X-Y-Z axis movement of the spindle head or the machine bed, the interference must be checked carefully before starting the operation.

#### 4-2. Lubrication



Change the lubricating oil every 6 months. Be sure to drain all oil from the unit first. When pouring oil into the unit, make sure to clean the area around the lubrication port so that no foreign material will enter the system. It may cause severe damage to the internal mechanism. Use recommended oil shown 4-4.

#### 4-3. Required Oil Quantity

(Unit: liter)

	MODEL	MR(M)	MR(M)	MR(M)	MR(M)	MR(M)	MX(M)
		120	160	200	250	320	160
QTY.(l) at Horizontal installation		0.2	0.6	0.6	0.8	1.0	0.25
QTY.(l) at Vertical installation		0.2	0.4	0.4	0.6	1.0	0.25

Daphne Multiway 32MT (Idemitsu) is provided in the unit before shipping.

#### 4-4. Recommended Lubricating Oil

Maker	Oil Name
IDEMITSU	Daphne Multiway 32MT
MOBIL	Vactra oil No.1
JX NIPPON OIL&ENERGY	Uniway EV 32
SHELL	Shell Tonna oil S32
COSMO	Dynaway 32

• Grade of Viscosity : ISO VG32

#### 4-5. Safety of Oil and Antirust Oil Used for the Unit

##### 4-5-1. Scope of application

- Specified lubricating oil
- Specified hydraulic oil (MR, MRT, MX, GT, TM2100·3100, TH2100·3100, TT(S)101·120, TT140, DM do not use)
- Antirust oil applied to the unit at delivery (Houghton Japan, Rust Veto 377)

##### 4-5-2. First-aid treatment

Aspiration: In case of much aspiration, go to a place where there is fresh air, and cover your body with a blanket to keep your body warm. Consult a doctor if necessary.

Sticking to your skin: Wipe off the oil, and wash your skin with water and soap. If you feel itchy or you get inflamed, consult a doctor immediately.

Entering your eye: Wash your eye with fresh water for at least 15 minutes, and then consult a doctor.

Accidental drinking: Consult a doctor immediately without vomiting forcibly. If you are polluted in your mouth, wash with water thoroughly.

- For lubrication oils and hydraulic oils other than specified ones, and antirust oils prepared by the customer, refer to the safety information prepared for respective oils.

##### 4-5-3. Flammable characteristics

- Watch out for fire since lubricating oil and hydraulic oil are flammable. Hazardous substances will be generated if they combusted.
- The flash point of lubricating oil and hydraulic oil put in the unit at the delivery exceeds 200°C. It may be different from that of the lubricating oil and hydraulic oil prepared by the customer.

- Antirust oil is highly volatile and thus likely to catch fire, and also it mixes with air to form explosive mixture gas.
- The flash point of antirust oil applied to the unit at the delivery is 38°C. It may be different from that of the antirust oil prepared by the customer.

#### **4-5-4. Disposal of lubricating oil and hydraulic oil**

Dispose of used lubricating oil and hydraulic oil exhausted from this unit in accordance with the laws and regulations of your country. You may suffer punishment if you disposed of waste oil without following the laws and regulations.

## **5. Inspection**

### **Daily inspection**

- 1) Confirm that the NC rotary tables (including jigs, if attached) are securely fixed.
- 2) Confirm that the chips accumulating in a rotary part of NC rotary table are removed.
- 3) Confirm that the electric connection cables and hoses are not damaged and the pneumatic pressure is appropriate.
- 4) Confirm that the machine-zero operation and indexing operation and position.
- 5) Confirm that there is no abnormal vibration or noise. (eq. Body and motor)
- 6) Confirm that there is no abnormal heating. (eq. Body and motor)

### **Periodic inspection (Inspect the following items every six months.)**

- 1) Confirm that muddiness of the lubricating oil.
- 2) Confirm that the connectors are securely attached and there is no damage on the cables.
- 3) Confirm that corrosion and breaking of the wiring in the motor case.

## **6. Use of NC Rotary Table**

This unit is installed on the machining centers, and on its table surface the chuck or fixture is attached to clamp the workpiece. It indexes the angle of machining position by the control of machining center or Kitagawa's own controller. During the machining, the working fluid is supplied to retain the workpiece.

## 7. Table Clamp and Unclamp

### 7-1. General Instruction



When the table is positioned, activate the table clamp, When the table is in motion, inactivate the table clamp. Improper procedures in table clamp and/or unclamp may cause severe damage to the internal mechanism. This unit is supplied with two pressure switches for table clamp and unclamp for added safety.



Make sure that your cutting operation on the unit does not exceed the table clamping force specified on the specification sheet. This may cause damage to the internal mechanism.



If some excessive pressures remain when it is unclamped, the unit is operating under a half-clamp situation. This may cause severe damage to the internal mechanism.

### 7-2. Inlet Pressure for Table Clamp

- 1) Use an appropriate filtration system. (Air Filter, Mist separator, Regulator, Drain catcher set)
- 2) Connect the pipe exclusive for air pressure durable to max. operating pressure over 0.6 MPa to the air pressure supply port. The air pressure supply port is provided on the motor case. See the external view attached for details.
- 3) Use this unit in the air pressure range of 0.45 to 0.6 MPa.
- 4) If the tail spindle is used, branch the air pressure from the NC rotary table to the tail spindle by using a tail spindle connection port provided on the NC rotary table. See the external view attached for the location of connection.

### 7-3. Air purge



According to the circumstance of use, the dew may be occurred in the motor case. Air is exhausted from the portion of the air exhaust so that it causes the obstacle of electric parts or each part.

The air purge is performed by air branched inside of NC table that uses air for clamp. Be sure to use the clean air (passing through air filter, mist separator, regulator and drain catcher) passing through the filter. If the air contains water content (moisture), oil content, etc., it is entered in the motor cover, thus causing in equipment damage. The air inside of motor case is exhausted from the air exhaust port.

In case that the portion of the air closed, motor case or motor etc. may be damaged so that the dew cannot be exhausted and that air pressure is kept in the motor case. Therefore the portion of exhaust should not be closed.

When exhausting, though exhaust sound occurs, there is no trouble.

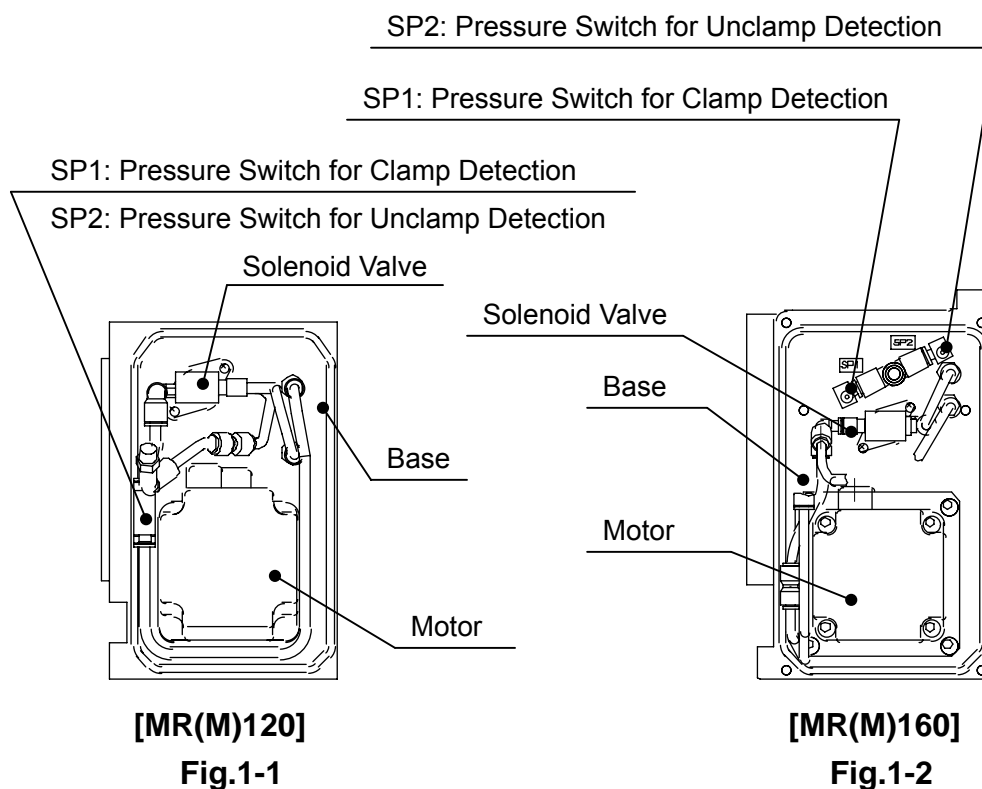
#### 7-4. Confirmation of Clamp and Unclamp

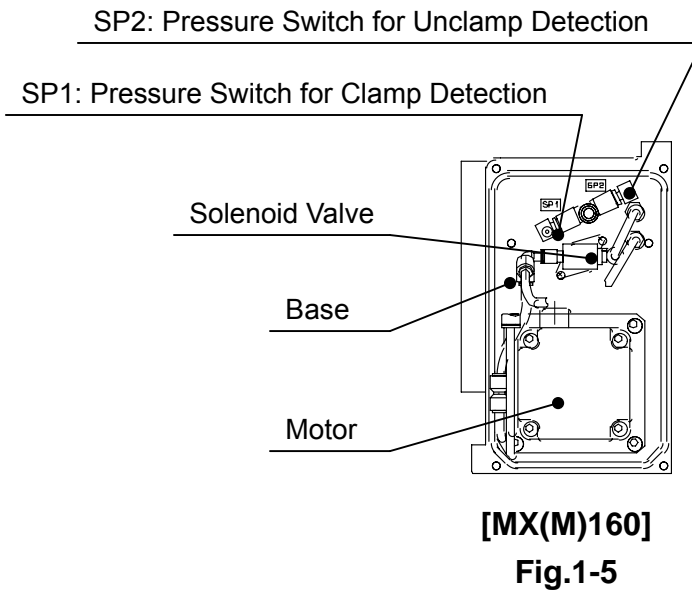
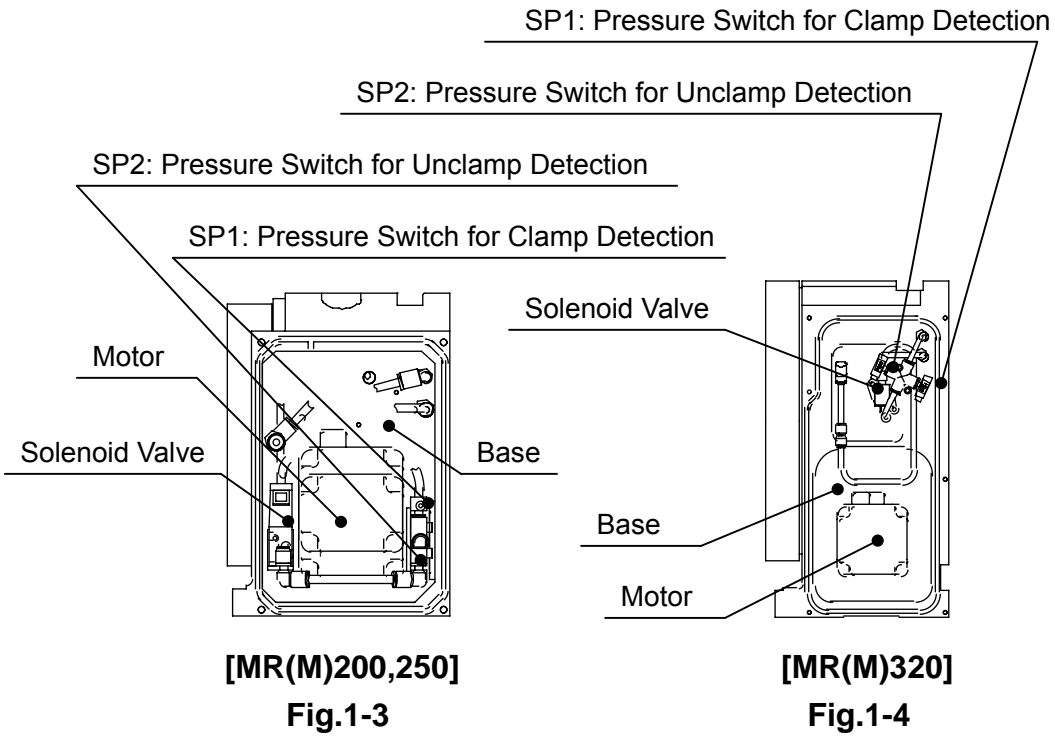
The unit is equipped with two built-in pressure switches for clamp/unclamp detection as shown in Fig.1-1~1-5.

The set up pressure of each switch for pneumatic systems is as follows:

Signal	Clamp Signal (SP1)	Unclamp Signal (SP2)
Pneumatic	0.25 MPa PS1000-R06L-Q-X140	0.055 MPa PS1100-R06L-Q-X141

The pressure switches SMC CORP made are used.





## 7-5. Solenoid Valve for Clamp and Unclamp

For Pneumatic Clamping, a solenoid valve is equipped inside.

Please refer to the specification drawn in outside view and wiring diagram.

### 【 Excitation Unclamp Spec. 】

Solenoid: ON ... Unclamp

Solenoid: OFF ... Clamp

### 【 Excitation Clamp Spec. 】

Solenoid: ON ... Clamp

Solenoid: OFF ... Unclamp



Since there is polarity in the pressure switch by SMC CORP., a proximity switch, and a solenoid valve, please refer to the wiring diagram.

## 8. Mounting the Workpiece



Securely mount the workpiece to the unit. If this is not done properly, it may cause severe injury and/or accident as well as poor indexing accuracy.



Avoid mounting a workpiece which has poor flatness or perpendicularity directly to a table face. This may strain the table and prevent smooth rotation, which may result in very poor indexing accuracy. Shimming may be required to prevent this problem.



Clamp the work in equipartition on the rotary table as much as possible.

## 9. Maintenance Work

### 9-1. Corrective Action in Case of Failure, and Disassembly

See the “Troubleshooting” if a failure occurred in the unit due to any reason. Also, for the disassembly procedure when performing the maintenance work, refer to the parts list and the procedure given in the corresponding maintenance item.

### 9-2. Before Performing Maintenance Work

When performing the maintenance work, shut off the power (primary power supply) of the machining center or Kitagawa’s own controller to set the pressure adjusting valve of air combination that supplies the air to the NC rotary table to 0 MPa or shut off the power of the air compressor to exhaust the compressed air, so as to stop the supply of the working fluid.



Perform the maintenance work with the workpiece removed. Performing the work with the workpiece left on the table may cause the workpiece to be dropped out, resulting in injuries.



Appropriate value in each maintenance item has been set for smooth function of each device, and thus you should observe it. Performing the maintenance work without observing the appropriate value may cause NC rotary table to fail or each device to be damaged.



Clamp the table clamp device of NC rotary table when removing the workpiece.



## 10. Adjustment of Backlash between Worm Wheel and Worm Gear

The amount of backlash has been adjusted to the appropriate range at time of the shipment from the factory. However, if it becomes necessary, excessive backlash between the precisely machined double-lead worm and worm wheel can be eliminated easily with two slightly different inclined leads provided on the worm gear. Appropriate amount of backlash between the worm and worm wheel is shown below. The figures apply only when the unit is cold. The amount of backlash will be affected by thermal expansion when the unit warms up during operation.



If the amount of backlash is too small, it may cause a heat seizure of the worm and worm wheel.

○ Optimum values of backlash

MODEL	MR(M) 120	MR(M) 160	MR(M) 200	MR(M) 250	MR(M) 320	MX(M) 160
Backlash in Circular Length of Table O.D. ( $\mu\text{m}$ )	12~37	13~39	13~38	13~41	14~41	14~41
Backlash in seconds	39~118	33~98	26~78	22~68	18~53	35~105

If it is necessary to adjust the amount of backlash, measure the backlash using the following procedure:

### 10-1. Measuring the Backlash of the Worm Gear [See Fig.2]

- 1) Set a dial gauge on the side face of the guide block on the top surface of the table.
- 2) Turn the table slowly by using the tap on the surface of the table as shown in Fig.2. And read the value of the dial gauge when tooth of the worm wheel makes contact with a worm shaft. At this time, the rotating torque added to the table is as follows. Then, rotate the table on the same conditions to the opposite direction. The difference of these measurements is the amount of backlash.

MODEL	MR(M) 120	MR(M) 160	MR(M) 200	MR(M) 250	MR(M) 320	MX(M) 160
Torque added to table T(N·m)	11	15	17	26	30	15

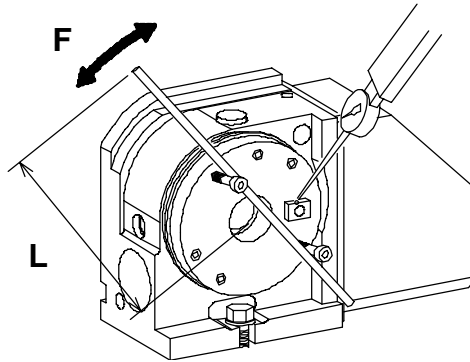
- 3) The above measurements should be conducted at four different points by rotating the table 90 degrees at a time. Compare the readings with the correct amount of backlash shown above. If the reading is out of the range specified, take the following procedures to adjust the backlash so that the minimum reading is within the correct range specified above.

$$T = F \times L$$

T: Torque (N·m)

F: Effort force (N)

L: Distance from table center to point to add power F (m)



**Fig.2**

## 10-2. Adjusting the Backlash of the Worm Gear [See Fig.3-1, Fig.3-2]



Before proceeding to the backlash adjustment, you must turn off the power to the control unit and set the NC Rotary Table in the "unclamp" mode. If this caution is ignored, your hands or clothes may be caught in the gear while the gear is rotating resulting in serious injury.

- 1) For the backlash adjustment, you must discharge the lubricating oil through the drain (you do not have to do this for model MR(M)200).
- 2) For vertical installation, remove the hexagon socket headless tapered pipe plug (3/8) ① located on the reference plane for vertical installation, and for horizontal installation, remove the same pipe plug (model MR(M)160, MR(M)320, MX(M)160:3/8 or MR(M)120, MR(M)200, MR(M)250:1/4) ② located on the reference plane for vertical installation.
- 3) You will see the coupling ⑤ through the hole after removing the screw plug in the previous step. Rotate the worm shaft to a position where you can see the hexagon socket head cap screw ③, which fixes the coupling ⑤ and the worm shaft ⑦.
- 4) Loosen the hexagon socket head cap screw ③, which is fixed on the coupling ⑤.
- 5) Then, remove the cover ⑨, which is located on the opposite side on the motor case ⑥, and slightly loosen all four hexagon socket head cap screws (Only MR(M)320 is six) ⑩ which fix the bearing case ⑫. Then, slightly loosen the four adjustment screws (Only MR(M)320 is six) ⑪ the same amount. Now, re-fastening the four hexagon socket head cap screws (Only MR(M)320 is six) ⑩ will move the bearing case ⑫

ahead, which makes the backlash of the worm shaft ⑦ small.

## NOTICE

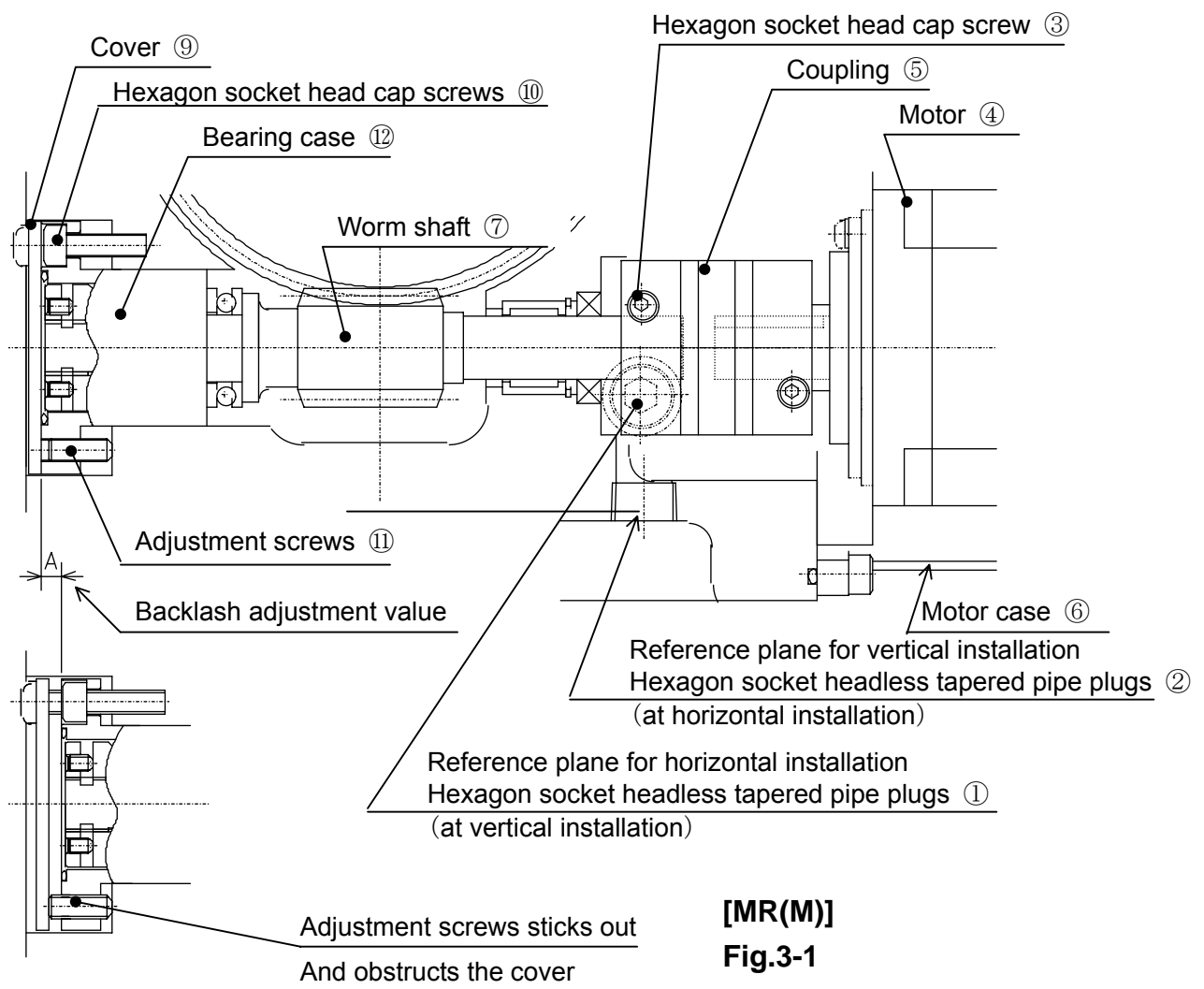
Since the pitch of the adjustment screw ⑪ is set to 1.0 mm, loosening the screw by one rotation will makes the backlash smaller as shown in the following table.

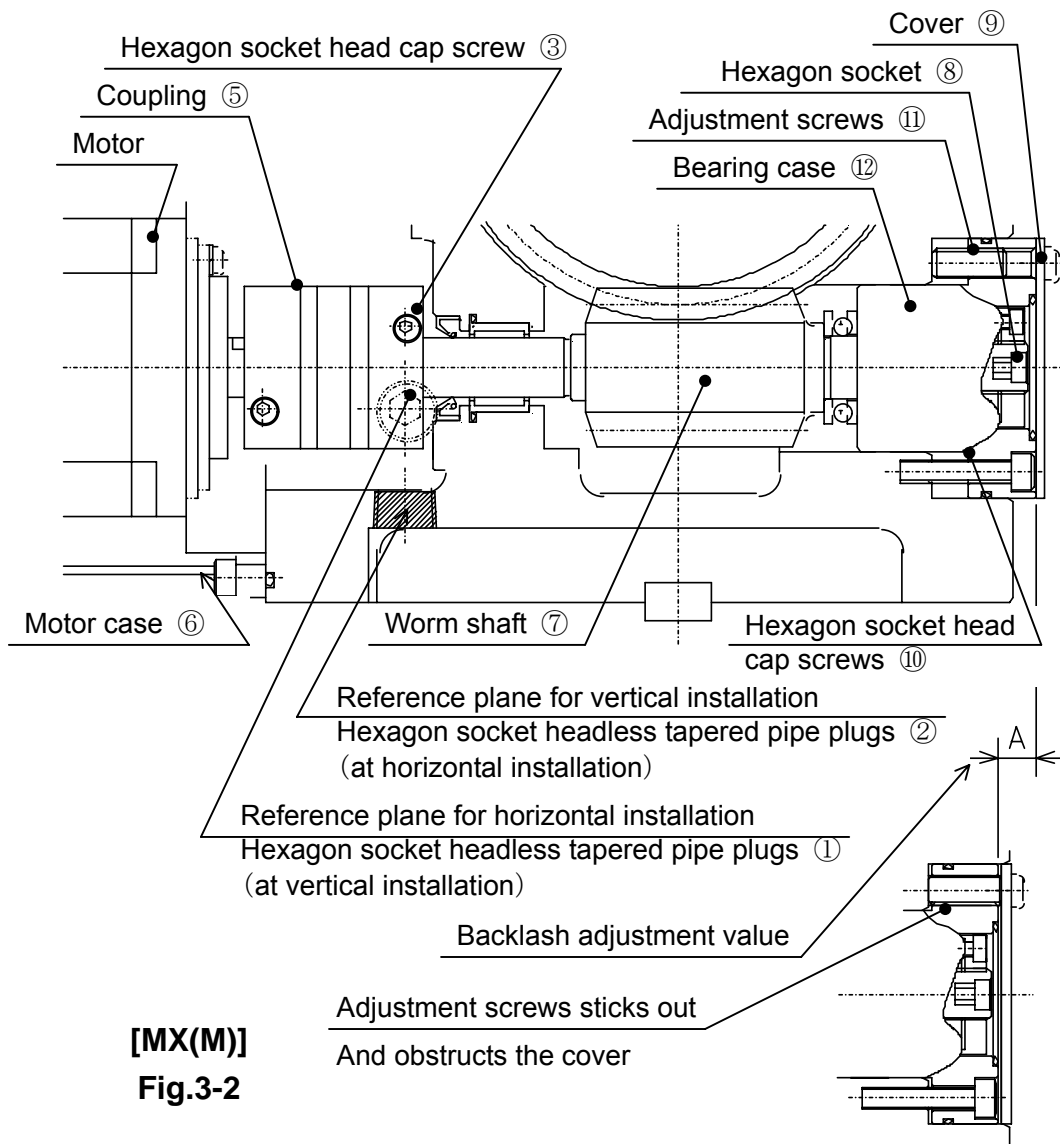
MODEL	MR(M) 120	MR(M) 160	MR(M) 200	MR(M) 250	MR(M) 320	MX(M) 160
Amount of face plate O.D. (μm)	About 44	About 36	About 36	About 32	About 45	About 36

Unscrewing adjusting screws ⑪ of MR(M)120,MR(M)160,MR(M)320 and MX(M)160 adjusting screws ⑪ may stick out from bearing case cover ⑨ mounting surface and it will cause the cover ⑨ not to be fixed. If this happens after backlash adjustment, replace adjusting screws to shorter ones according to the following table and adjust backlash again.

MODEL		MR(M) 120	MR(M) 160	MR(M) 320	MX(M) 160
Adjusting screw	Original screw	M6×12	M6×16	M6×16	M8×20
	Shorter screw	M6×8	M6×8	M6×10	M8×16

After adjusting, reassemble the worm gears by the reverse procedure of the above and securely tighten the bolts. After reassembling, measure the backlash again at outside periphery of the table and at the same position. Check that the backlash is proper. If the backlash is inadequate, adjust it again by the above method.





**[MX(M)]**  
**Fig.3-2**

## 11. ZRN device

\*\*\*\*\*

The contents of this item are unnecessary for the NC rotary table of Kitagawa's controller spec. and 4th axis spec. which don't have a dog for ZRN deceleration.

Machine zero position of this unit which set at shipment from factory is memorized due to the specification of servo motor with absolute encoder. Accordingly this unit does not have machine zero position device like as proximity SW and Dog. When changing machine zero position, instruction manual of controller (article for setting of machine zero position) would be referred.

\*\*\*\*\*

### 11-1. ZRN device on table

The ZRN device rotates clockwise (CW) on the standard specification.

The table datum groove comes to position at a right angle to the motor when connected to the NC unit. The dog, which activates the table speed reduction, is located inside the unit. The ZRN deceleration dog is mounted in the table and it can be mounted on the optional position of outer periphery. When shipping a product, the flank of the guide block fitted on the table has been positioned parallel to the reference plane for vertical installation. Fine adjustment of the ZRN position may be required at the customer at the time of interface with the NC controller of the machine.

### 11-2. ZRN device Adjustment [See Fig.4]

When the zero position is changed or when the rotation direction for return is changed to counterclockwise, adjust the ZRN position through the following procedures.

- 1) Remove the flange plug ① located on the top surface of the NC Rotary Table.
- 2) Rotate the table and, thorough the hole made by removing the hexagon socket flange head screw plug ①, loosen the hexagon socket headless set screw M3 ② that fixes the dog ③ to the main shaft of the Rotary Table.
- 3) Move the dog ③ to an appropriate position.
- 4) Upon the completion of the position adjustment, securely fasten the hexagon socket headless set screw ②. Also, securely fasten the hexagon socket headless set screw ①.

### 11-3. Sensor Mechanism

#### 1) Proximity Switch [See Fig.4]

The gap between the dog ③ and the proximity switch ④ should be adjusted to approximately 0.75mm by the 1.00mm pitch thread provided on the proximity switch ④.

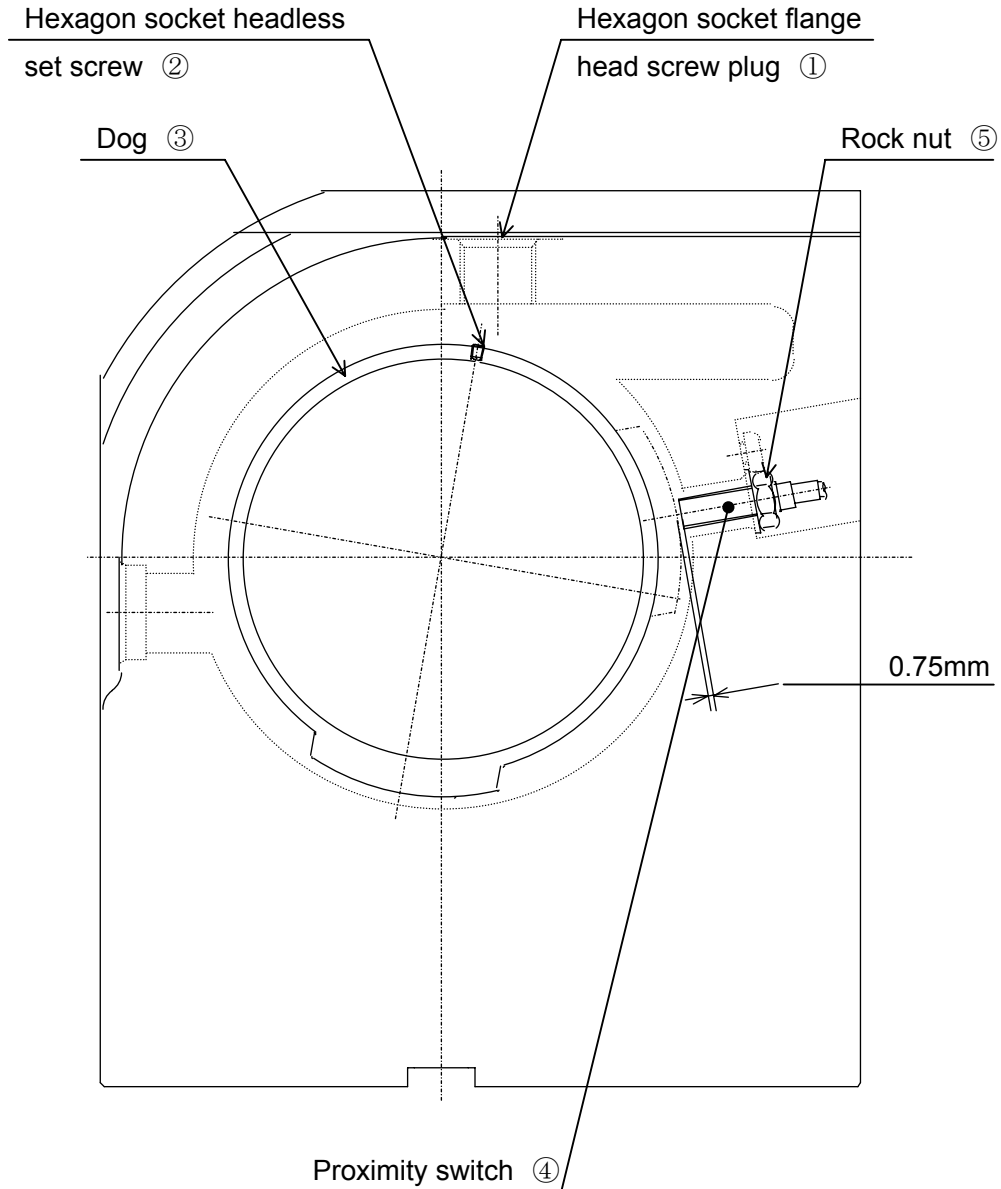


Fig.4

## 12. Motor Cover

### 12-1. Dismount

Please follow the procedure below for removing the motor cover. [See Fig.5]

- 1) Loosen the hexagon socket head cap screws ⑩, which set the motor case ① on the base ⑩ and carefully detach the motor case ① by lifting the case upward. On this occasion, since wiring and air hose, etc. are connected, be careful not to apply load to them in consideration of their length.
- 2) Remove wiring, air hose and cannon connector of motor ②.

### 12-2. Waterproofing

In order to prevent the entering of coolant from the outside, O-ring ④ is used at the portion of connection between motor case ① and the body.

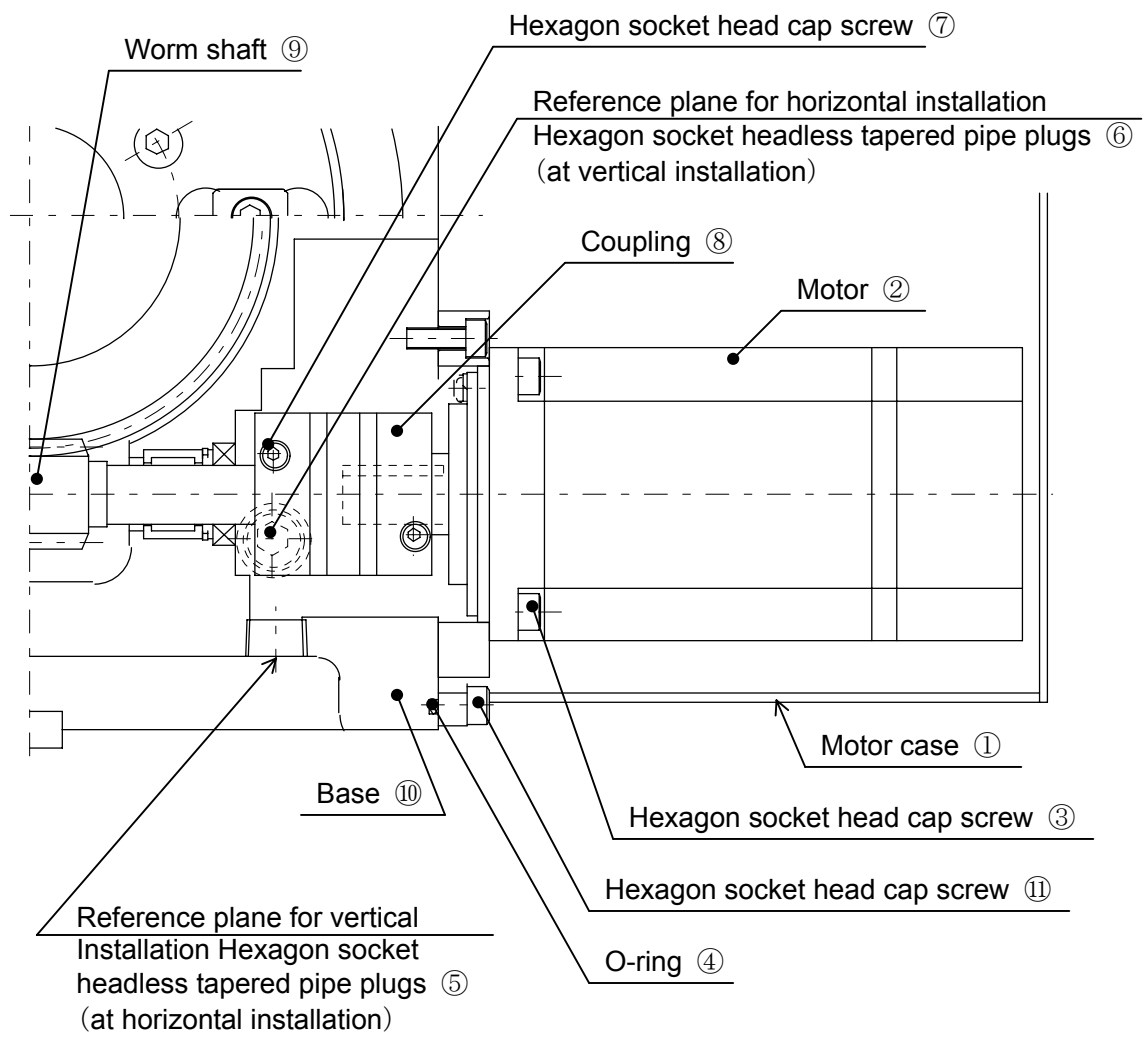


For detaching the motor, remove either of the hexagon socket headless tapered pipe plug, ⑤ or ⑥, and loosen the hexagon socket head cap screw ⑦ on the coupling ⑧ which connects the worm shaft ⑨ and the motor ②. Then, remove the four hexagon socket head cap screws ③ which secure the motor ② in order to detach the motor. When re-installing the motor ②, be sure to securely tighten the bolts and plugs.



When the motor case ① is re-installed, be carefully not to damage the O-ring. The damaged O-ring may allow the cutting water to enter the motor case.

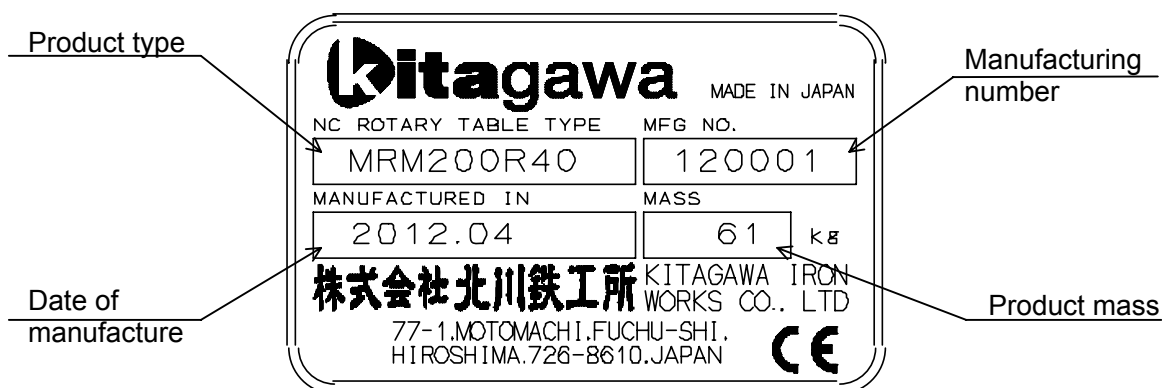




**Fig.5**

### 13. Troubleshooting

Check corresponding item given in this chapter to take corrective actions when the unit seems to be faulty. If the fault persists, please contact your sales agent (M/C maker) or us. When making an inquiry, let us know the product type and manufacturing number marked on the nameplate of the NC rotary table body.



#### Nameplate

Symptom ①: Table does not rotate

Possible causes	Corrective actions
No cable connection between NC rotary table and control unit	Check the cable for connection, and connect it
Broken cable between NC rotary table and control unit	Check the cable for continuity, and replace it
Faulty clamp device	See "Symptom ⑤"
Decentered workpiece, overloaded fixture, and friction torque of steady rest and rotary joint make the load torque larger than the motor torque	Compare the specification of NC rotary table with the work condition to make improvement
Use of unit out of specified temperature range	Adjust ambient temperature within specified temperature range

Symptom ②: Table does not rotate but generates a noise

Possible causes	Corrective actions
Motor makes a howling sound to try to rotate →Seizure of gears due to lack or deterioration of lubricating oil	Stop the use of NC rotary table immediately. Please contact the sales agent.
Gears generate a noise → Faulty rotation due to damaged gears	Stop the use of NC rotary table immediately. Please contact the sales agent.
Unit generates a noise at startup and stops soon →Faulty rotation because foreign substances mix in the oil bath	Supply lubricating oil until foreign substances come out of the drain port.

Symptom ③: Table does not rotate smoothly but generates a noise

Possible causes	Corrective actions
Noise is generated repeatedly during rotation →Gears are damaged	Stop the use of NC rotary table immediately. Please contact the sales agent.
→Faulty rotation of gears because foreign substances mix in the oil bath	Open the lubricating oil drain port, and supply lubricating oil until foreign substances come out of the drain port.
Load due to overloading exceeds motor output	Compare the specification of NC rotary table with the work condition to make improvement
Lack or deterioration of lubricating oil blocks smooth rotation	Check oil level, viscosity and change interval of lubricating oil
Faulty clamp device	See "Symptom ⑤"
Inappropriate backlash amount	Adjust backlash amount to appropriate value

Symptom ④: Chattering occurs during cutting

Possible causes	Corrective actions
Inappropriate clamp condition of NC rotary table or fixture	Check the clamp condition, and correct it
Excess cutting force is applied during cutting	Adjust cutting condition to the specified condition to change the cutting force to appropriate value
Faulty clamp device	See "Symptom ⑤"
Faulty locking of worm spindle in the backlash adjustment	Readjust
Fault due to damaged NC rotary table or expired life of components	Stop the use of NC rotary table immediately. Please contact the sales agent.
Fault occurs only during continuous cutting →Lack or deterioration of lubricating oil blocks smooth rotation →Inappropriate backlash amount	Check oil level, viscosity and date of last change of lubricating oil Adjust backlash amount to appropriate value
Chips accumulate in rotary part of NC rotary table	Remove accumulated chips in daily inspection

Symptom ⑤: Table is not clamped or unclamped

Possible causes	Corrective actions
Faulty solenoid valve	Replace the solenoid valve
Faulty clamp/unclamp confirming device (pressure switch)	Check and replace the clamp/unclamp confirming device (pressure switch)
Damage or connection failure of working fluid pipe for clamp	Check the piping for connection, and replace
Supply pressure of working fluid for clamp is lower than specified value	Change to appropriate value according to the specification
Back pressure acts to the air pressure exhaust port of solenoid valve, as the air purge port in the motor case is blocked.	Remove the cause that blocks the air purge port.
Faulty clamp device	Stop the use of NC rotary table immediately. Please contact the sales agent.
Fault due to damaged NC rotary table or expired life of components	Stop the use of NC rotary table immediately. Please contact the sales agent.

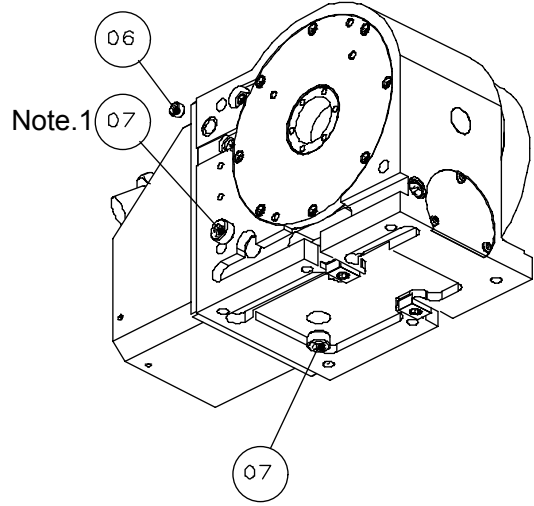
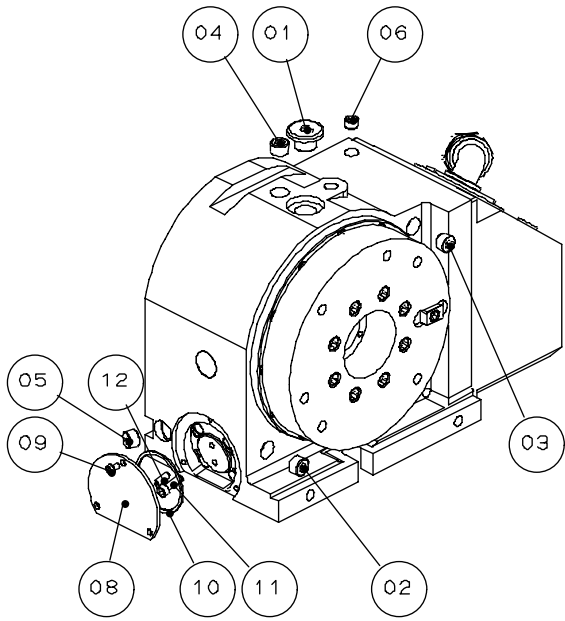
Symptom ⑥: Index accuracy error

Possible causes	Corrective actions
The unit is overloaded during rotation	Compare NC rotary table specification with work condition to make improvement
Workpiece is dislocated due to low clamp torque	Compare NC rotary table specification with cutting condition to make improvement
Zero return position is dislocated due to faulty zero point shift adjustment	Check the zero point and zero point shift amount
Faulty zero point dog position adjustment	Adjust the zero point dog
Faulty zero return deceleration signal device	Check the zero return deceleration signal device and replace the proximity switch
Faulty clamp operation	See "Symptom ⑤"
Inappropriate backlash amount	Adjust the backlash
Inappropriate backlash compensation amount	Change the backlash compensation amount
Worm shaft locking failure in backlash adjustment	Readjust
Fault due to damaged NC rotary table or expired life of components	Stop the use of NC rotary table immediately. Please contact the sales agent.

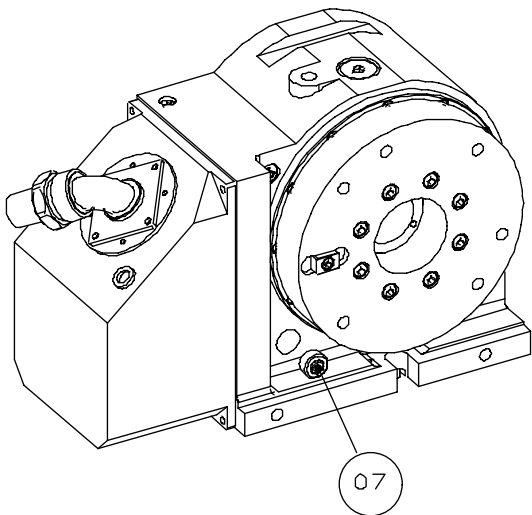
## 14. Parts List

○ Main Body

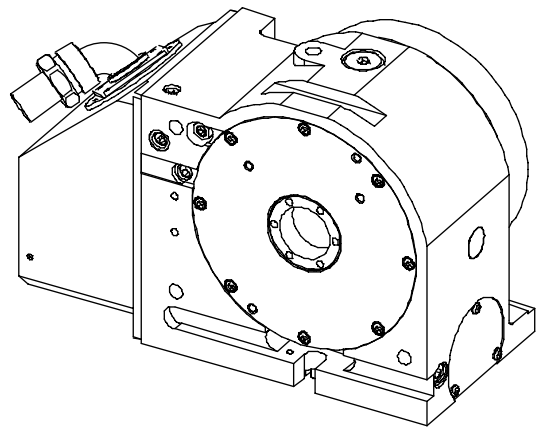
MARK	NAME	MR(M) 120	MR(M) 160	MR(M) 200	MR(M) 250	MR(M) 320	MX(M) 160	Q'ty	Recital
01	Hexagon socket flange head screw plug with O-Ring	M20x1.5						1	Gosho
02	Hexagon socket headless tapered pipe plug	Rc1/4	—		Rc1/2		—	1	
03	Hexagon socket headless tapered pipe plug	—	Rc1/2	Rc3/8	—		Rc1/2	1	
04	Hexagon socket headless tapered pipe plug	Rc1/4	—		Rc1/2	—		1	
05	Hexagon socket headless tapered pipe plug	—	Rc3/8		—	Rc3/8		1	
06	Hexagon socket headless tapered pipe plug	Rc1/4						2	
07	Hexagon socket headless tapered pipe plug	Rc1/4	Rc3/8	Rc1/2			Rc3/8	2	
08	Cover							1	
09	Machine screw	M4x8 (4)		M5x8 (3)	M6x10 (3)	M5x10 (3)	M5x8 (4)	(*)	
10	O-ring	S35.5		—	S90	S53	S35.5	1	
11	Hexagon socket head cap screw	M6x20 (4)			M6x25 (4)	M6x20 (6)	M6x30 (4)	(*)	
12	Hexagon socket headless set screw (Flat Point)	M6x12 (4)	M6x16 (4)		M6x25 (4)	M6x16 (6)	M8x20 (4)	(*)	



**Note.1 Left Hand**



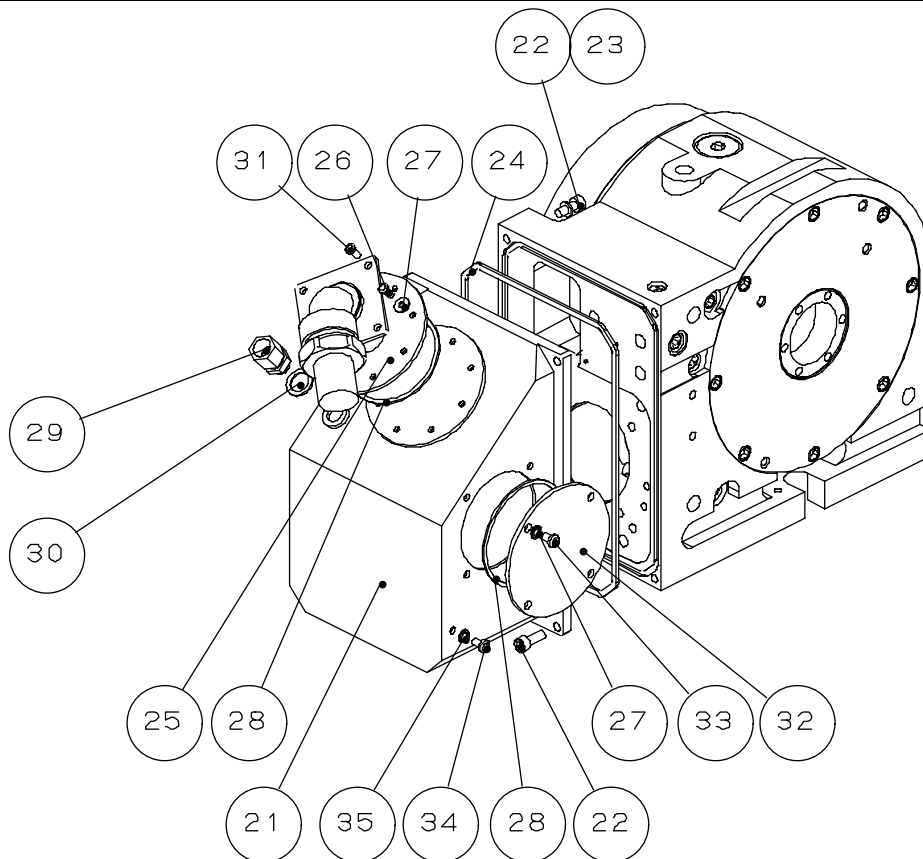
**Front Side**



**Back Side**

○ Motor Case(For M Signal)

MARK	NAME	MR(M) 120	MR(M) 160	MR(M) 200	MR(M) 250	MR(M) 320	MX(M) 160	Q'ty	Recital	
21	Motor case								1	
22	Hexagon socket head cap screw	M5x20 (4)	M6x16 (4)			M6x16 (6)	M6x16 (4)	(*)		
23	Seal washer	5S1	—						1	
24	O-ring	GS180	GS195	GS210	GS245	GS290	GS195	1		
25	Connector plate	—							1	
26	Machine screw	—						M5x14	4	
27	Seal washer	—						5	8	
28	O-ring	—						S112	2	
29	Bulkhead connector	—						KQE06-02	1	SMC
30	Seal washer	—						14S1	1	
31	Machine screw	M4x10							4	
32	Cover	—							1	
33	Machine screw	—						M5x8	4	
34	Machine screw	M5x8							1	
35	Seal washer	5							1	

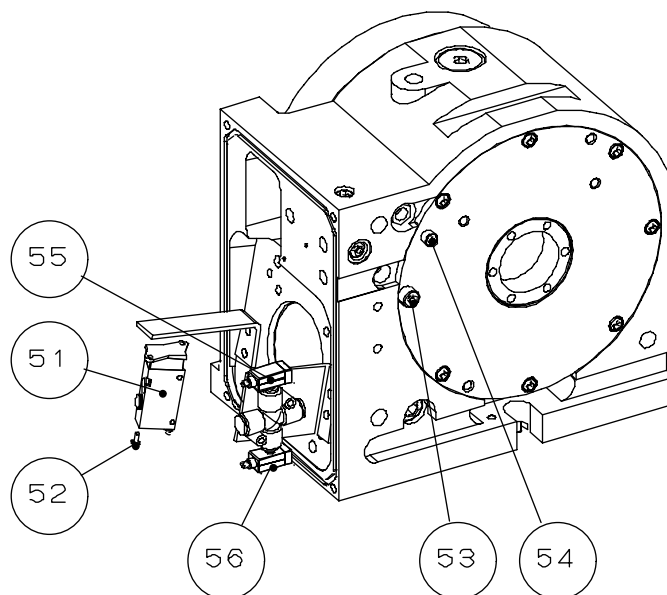


When the specification is 4th axis, the motor case and the cable are different from the above figure.

For detailed models, refer to attached outside view.

○ Clamp Detection Device

MARK	NAME	MR(M) 120	MR(M) 160	MR(M) 200	MR(M) 250	MR(M) 320	MX(M) 160	Q'ty	Recital
51	Solenoid valve	VK332-5DS-M5-F-Q					VQZ2921B-5L1 -C6-F-Q	1	SMC
52	Machine screw	M3x6	—			M3x6		2	
53	Plug silencer	PSA102					—	1	TAIYO
	Silencer	—					EBKX-A9012		SMC
54	Plug silencer	PSA101					—	1	TAIYO
55	Pressure switch for clamp detection	PS1000-R06L-Q-X140						1	SMC
56	Pressure switch for unclamp detection	PS1100-R06L-Q-X141						1	SMC



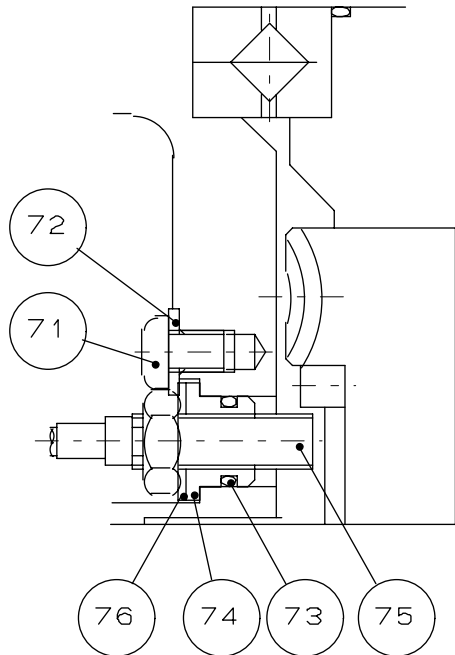
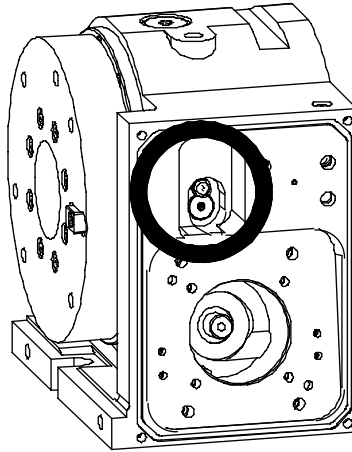
When the specification is different, the model and the installation position of the solenoid valve and the pressure switch are different from the above figure.

For detailed models, refer to attached wiring diagram.



○ Built-in ZRN (Zero Return) Device

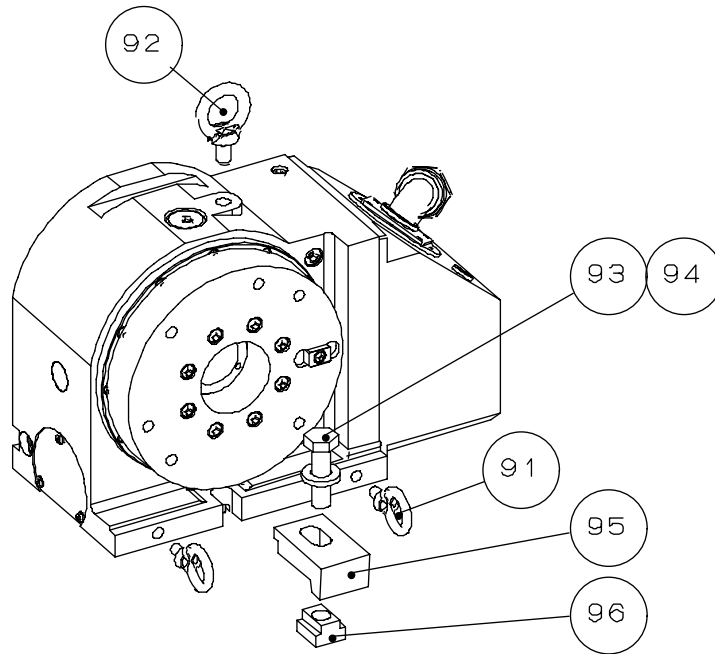
MARK	NAME	MR(M)	MR(M)	MR(M)	MR(M)	MR(M)	MX(M)	Q'ty	Recital
		120	160	200	250	320	160		
71	Machine screw	M6x8						1	
72	Washer	6						1	
73	O-ring	P10						1	
74	Holder for Proximity switch							1	
75	Proximity switch	FL7M-2K6H						1	Yamatake
76	Seal washer	DT-1-8						1	Mitsubishi Cable



No proximity switch is provided for the M signal type.

○ Accessory

MARK	NAME	MR(M) 120	MR(M) 160	MR(M) 200	MR(M) 250	MR(M) 320	MX(M) 160	Q'ty	Recital
91	Eye bolt	M8	M10			M12	M10	2	
92	Eye bolt	M8	M10	M12			M10	1	
93	Hexagon head bolt	M12x45 (2)	M16x55 (2)	M16x50 (2)	M16x65 (4)	M16x75 (4)	M16x55 (2)	(*)	Strength Dimension 8.8
94	Washer	12 (2)	16 (2)		16 (4)		16 (2)	(*)	
95	Clamp	—					—	4	
96	T-slot nut	1412 (2)	1816 (2)		1816 (4)		1816 (2)	(*)	



When the specification is different, the clamping parts and guide block are different from the above figure. For detailed models, refer to attached outside view.

## 15. Storage

### NOTICE

When removing the unit from the machine table, apply oil to prevent rust and store it on a stable wooden stand or in the original crate with the appropriate cover to protect it from dust and maintain its accuracy.

Note: Some raw wood is chemically unstable and may cause rust on the unit.

## 16. Disposal of NC Rotary Table

Dispose of this unit in accordance with the laws and regulations of your country.

You may suffer punishment if you disposed of this unit without following the laws and regulations.

## 17. Indexing Accuracy and Pitch Error

### NOTICE

“ What is the linear length at the table circumference with 20 seconds cumulative indexing accuracy ?”

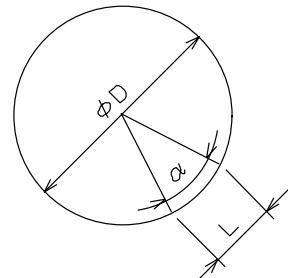
“ What is the angle with a cumulative pitch error of 0.01mm ?”

To answer these questions, use the following formula representing the relationship between the angle and linear length at the table circumference.

D: Diameter of Workpiece (mm)

$\alpha$  : Angle (seconds)

L: Linear length at the table circumference (mm)



$$\frac{L}{\pi \times D} = \frac{\alpha}{360^\circ \times 60' \times 60''} \dots\dots\dots (1)$$

$$\alpha = \frac{360 \times 60 \times 60 \times L}{\pi \times D} = \frac{4.125 \times L \times 10^5}{D} \dots\dots\dots (2)$$

$$L = \frac{\alpha \times \pi \times D}{360 \times 60 \times 60} = 2.424 \times 10^{-6} \times \alpha \times D \dots\dots\dots (3)$$

(Examples)

Assuming the diameter of the workpiece is 100mm, and by using formula (2), the cumulative indexing accuracy of 20 seconds as linear length at table circumference will be:

$$L = 2.424 \times 20 \times 100 \times 10^{-6} = 0.004848mm$$

Therefore, the length is approximately 0.0048mm.

And converting the cumulative pitch error of 0.01mm to an angle, use formula (3):

$$\alpha = \frac{4.125 \times 0.01 \times 10^5}{100} = 41.25''$$

Therefore, the angle is approximately 41 seconds.

Thus, by using the formula (2) and (3), the indexing precision and pitch error can be converted in terms of linear length and angle.

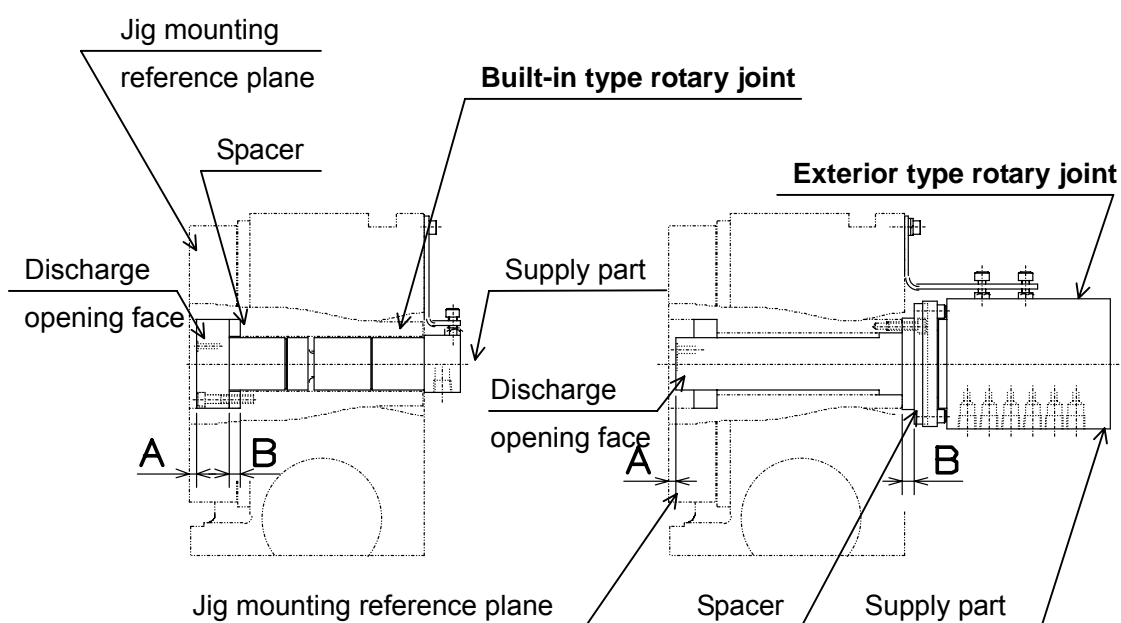
## 18. Mounting Rotary Joint (Option)

### 18-1. Alignment of discharge opening face

To mount the rotary joint, the rotary joint discharge opening face must be aligned with the jig mounting reference plane so that hydraulic oil does not leak to the jig (A-size in the following figure).

To align the position of the rotary joint discharge opening face, the thickness of the spacer attached to the rotary joint must be adjusted (B-size in the following figure).

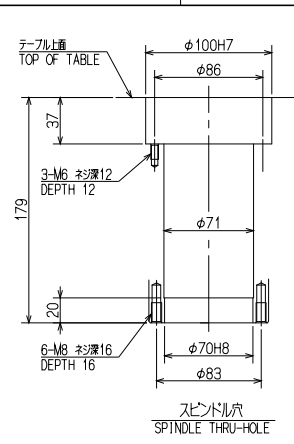
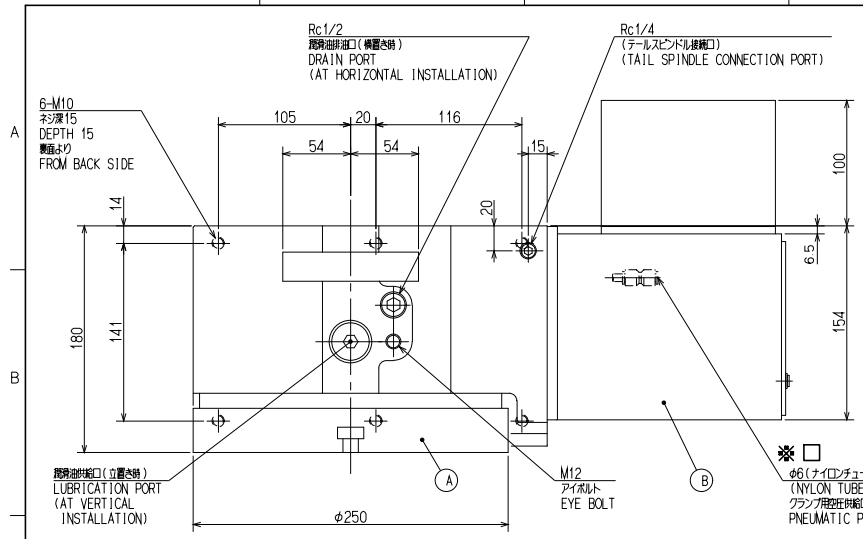
When the rotary joint is mounted additionally or a set of rotary joint parts is replaced, check the product type and manufacturing number, and contact Kitagawa branch or your agent.



### 18-2. Pining to supply part

To route the pipe to the supply part of the rotary joint, determine a hose length so that the hose will not be moved by the movement of a table for a mounted machine.

Moreover, when turning a joint screw, use the tightening tool carefully so that unreasonable force will not be applied to the supply part.

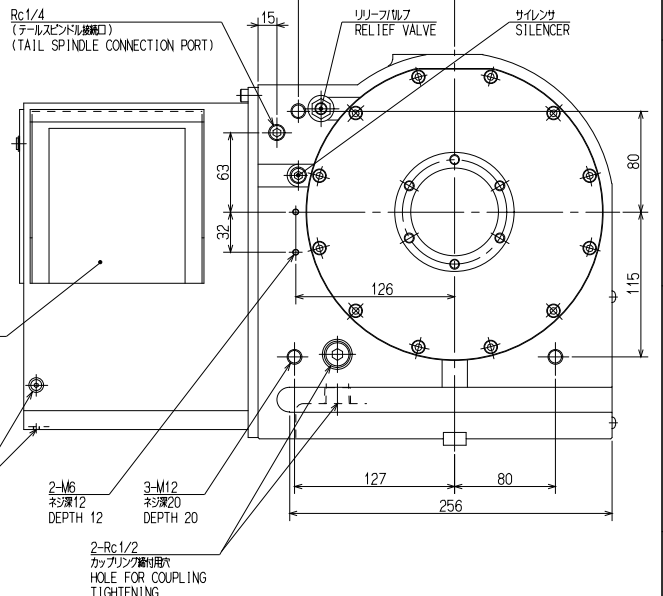
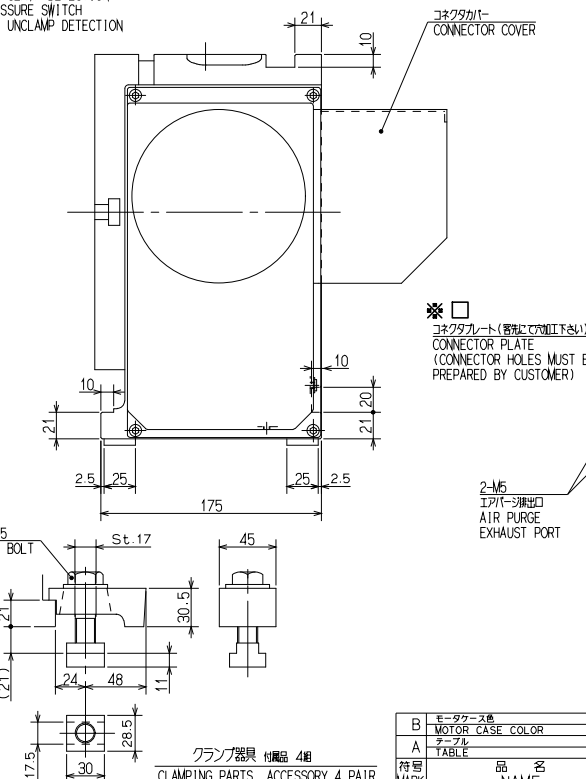
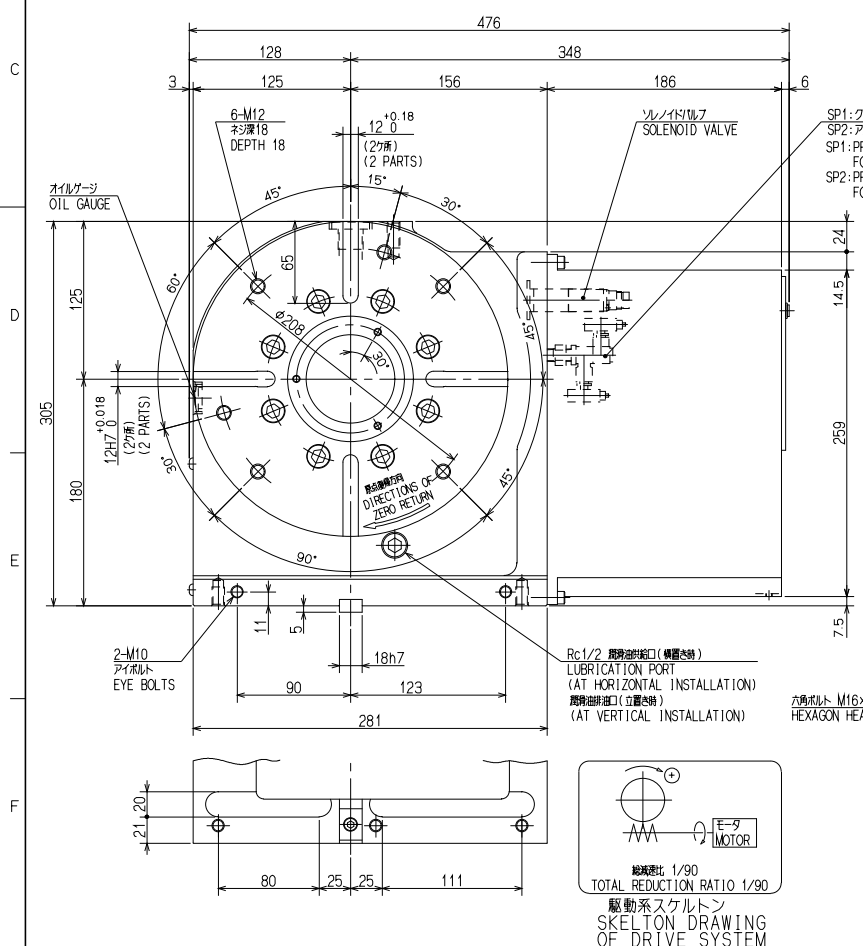
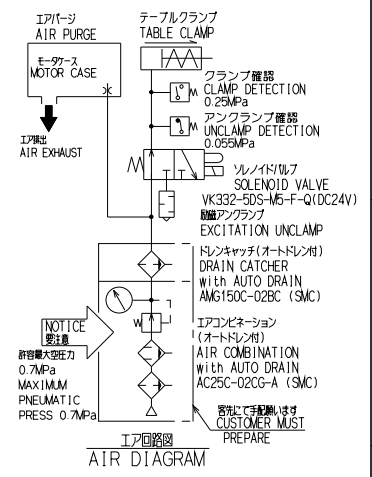


**注記 NOTE**

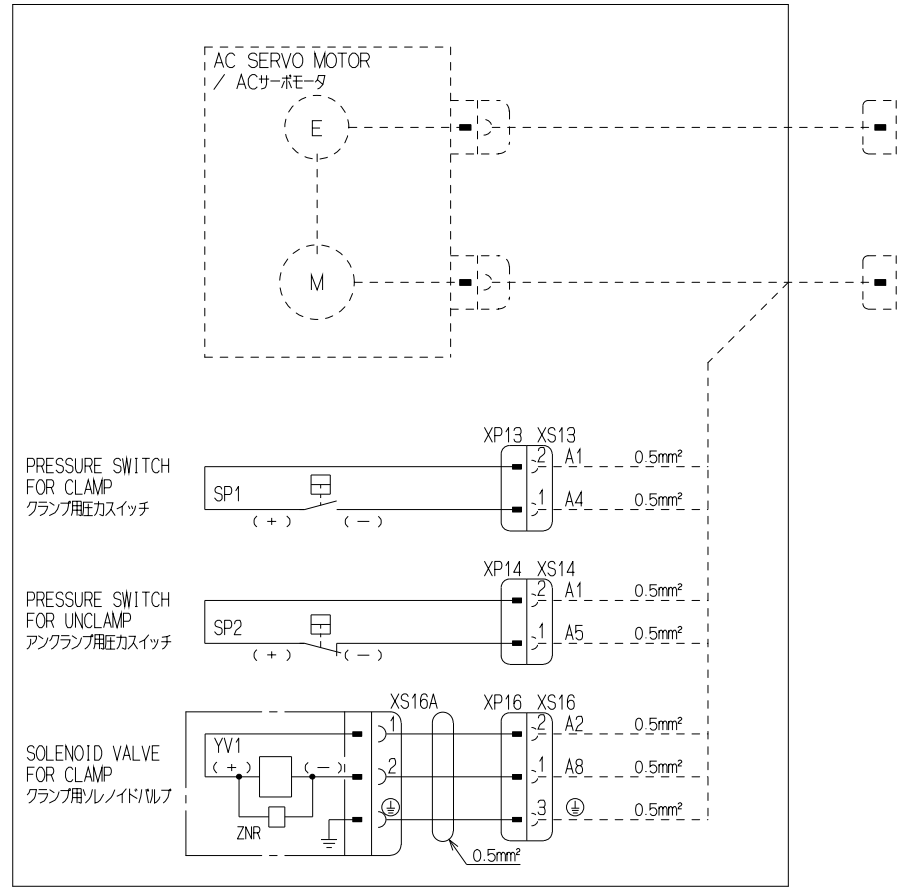
- ※ □ 1) ACサーボモータ: 事前に下記記載の動作確認を。 WITHOUT MOTOR (SETTING WORKS OF MOTOR AT CUSTOMER) 取り付可能なモータ: FANUC MODEL A06B-0075-B103(81S 8/3000 /カモコ-9#1281A) MOUNTING POSSIBLE MOTOR: FANUC MODEL A06B-0075-B103(81S 8/3000 #1281A)
- 2) 図面上記載のない精度要求は、カタログ記載の値とします。 ACCURACY STANDARDS EXCEPT STATED IN THIS DRAWING SHOULD BE APPEALED TO THAT IN CATALOGUE.
- 3) 戻り速度は 22.2 min<sup>-1</sup> 以下、再クランプ速度は 0.6 min<sup>-1</sup> 以下に設定して下さい。 SPEED OF ZERO RETURN SHOULD BE SET LESS THAN 22.2 min<sup>-1</sup>. AND ITS CREEP SPEED SHOULD BE SET LESS THAN 0.6 min<sup>-1</sup>.
- 4) ケーブル接続はモータースタンド(側面、背面)が可能です。 CABLE CAN BE CONNECTED FROM 2 DIRECTIONS (SIDE, BACK) OF MOTOR CASE.
- 5) 本機はエアパージ仕様のため配管接続口からエアパージが必要です。 THIS ROTARY TABLE IS DESIGNED UNDER THE CONDITION OF AIR PURGE. ACCORDINGLY CLEAN AIR FROM PNEUMATIC PORT HAVE TO BE SUPPLIED. BY AIR UNIT (AMG150-02BC & AC25C-02CG) OF AIR DIAGRAM.
- ※ □ 6) 本テーブルは、弊社回転テーブルにて動作確認をしております。お客様にて一度取り付後、再度動作確認下さい。 MOVEMENT CONFIRMATION IS DONE WITH EQUIPMENT OF KITAGAWA. OPERATION CHECK SHALL BE CARRIED OUT AT THE SITE.
- 7) 本機を機械に設置する場合は、周辺の手形を止める為、外形寸法より10mm以上の余裕を確保下さい。 WHEN YOU INSTALL A ROTARY TABLE ON A MACHINE, PLEASE KEEP A CLEARANCE OF MORE THAN 10 mm BETWEEN THE ROTARY TABLE AND THE MACHINE SPLASHGUARD IN ORDER TO PREVENT THE INTERFERENCE.

仕様 SPECIFICATIONS	
引出し精度 INDEXING ACCURACY	20 sec以内
再現精度 REPEATABILITY	4 sec以内
テーブル最高回転速度 MAXIMUM ROTATION SPEED	22.2 min <sup>-1</sup>
許容最大質量 ALLOWABLE MASS OF WORK	横軸: 250 kg 縦軸: 125 kg
許容最大トルク ALLOWABLE TORQUE	6000 N・m
許容最大空気圧 MAXIMUM PNEUMATIC PRESS	0.7 MPa
総減速比 TOTAL REDUCTION RATIO	1/90
質量 MASS OF ROTARY TABLE	85 kg
慣性モーメント (モータ側) MACHINE INERTIA (BEHIND MOTOR SHAFT)	0.000308 kgm <sup>2</sup>

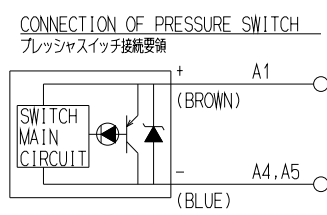
CUSTOMER		
MF No.	DATE	REASON OF REVISION



CAREER	61E247109	SCALE	TYPE	MR250RAE14	WEIGHT	kg
W.D.	61E819477	1:3	NAME	NCテーブル NC ROTARY TABLE		
MANAGER	CHIEF	DRAWN BY	MR250RAE14 ガイキョウ OUTSIDE VIEW			
		E. KUR	DRW NO.	61E269366		
		01081	DATE	13.04.04		
KITAGAWA IRON WORKS CO., LTD.						



MARK 記号	NAME 品名	MAKER メーカー	TYPE 型式	Q'ty 個数	REMARKS 備考
SP1	PRESSURE SWITCH プレッシャスイッチ	SMC	PS1000-R06L-Q-X140	1	0.25MPa 1a
SP2	PRESSURE SWITCH プレッシャスイッチ	SMC	PS1100-R06L-Q-X141	1	0.055MPa 1b
YV1	SOLENOID VALVE ソレノイドバルブ	SMC	VK332-5DS-M5-F-Q	1	DC24V
XS16A	CONNECTOR コネクタ	SMC	VK300-82-1	1	SOLENOID VALVE ACCESSORIES ソレノイドバルブ付属
XP13	PLUG HOUSING プラグハウジング	MOLEX	52116-0240	1	
XP14	PLUG HOUSING プラグハウジング	MOLEX	52116-0241	1	
XP16	PLUG HOUSING プラグハウジング	MOLEX	52116-0341	1	
XS13	RECE HOUSING リセハウジング	MOLEX	52117-0240	1	
XS14	RECE HOUSING リセハウジング	MOLEX	52117-0241	1	
XS16	RECE HOUSING リセハウジング	MOLEX	52117-0341	1	



SPECIFICATIONS  
プレッシャスイッチ仕様

OPERATING VOLTAGE RANGE 使用電圧範囲	DC12~24V
SWITCHING CURRENT 制御出力開閉電流	5~40 mA
LEAKAGE CURRENT 漏れ電流	max. 1.0 mA
RESIDUAL VOLTAGE 制御出力残留電圧	max. 5 V
OUTPUT CONTACT 出力接点	NO (PS1000-R06L-Q-X140) NC (PS1100-R06L-Q-X141)

NOTE 注意

1) THE COMMON LINE OF A PRESSURE SWITCH IS (+) COMMON.  
プレッシャスイッチの共通ラインは+コモンです

SOLENOID VALVE SPECIFICATIONS  
ソレノイドバルブ仕様

RATED SUPPLY VOLTAGE 定格電源電圧	DC24V
POWER CONSUMPTION 消費電力	4W

CAREER	61E366368, 61E818260	SCALE	TYPE	MR202RAE01	WEIGHT	kg
MANAGER	CHIEF	DRAWN BY	3RD ANGLE	NC ROTARY TABLE NCテーブル		
		N.MASUMUNE		NAME	WIRING DIAGRAM タンキシヨウ	
KITAGAWA IRON WORKS CO., LTD.		DATE	DRW NO.	61E819477		

CUSTOMER		
MOD. NO.	DATE	REASON OF REVISION
1	13.12.12	ADJUSTMENT

**要注意 NOTE**

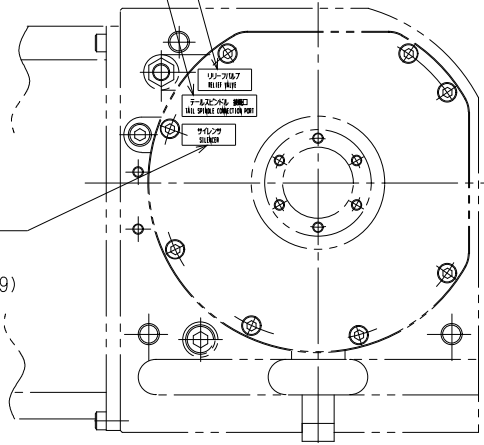
1) 図はMR160RAV00のメイバン位置を示しています。  
 貼り付け位置詳細は外形図を参考にしてください。  
 THE POSITION OF MR160RAV00 NAMEPLATE IS SHOWN IN THIS DRAWING.  
 THE POSITION OF NAMEPLATE SHOULD BE REFERRED TO OUTSIDE VIEW.

A  
B  
C  
D

リリーフバルブ  
RELIEF VALVE  
シールR  
(61E448855)

Rc1/4  
テールスピンドル接続口  
TAIL SPINDLE CONNECTION PORT  
シールN  
(61E445687)

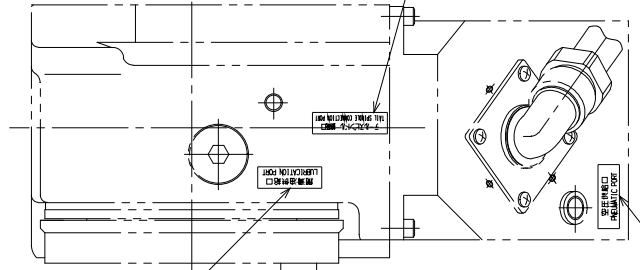
サイレンサ  
SILENCER  
シールQ  
(61E445689)



背面から見る  
SEE FROM A BACKSIDE

Rc3/8  
潤滑油排出口  
DRAIN PORT  
シールC  
(61E430247)

Rc1/4  
テールスピンドル接続口  
TAIL SPINDLE CONNECTION PORT  
シールN  
(61E445687)

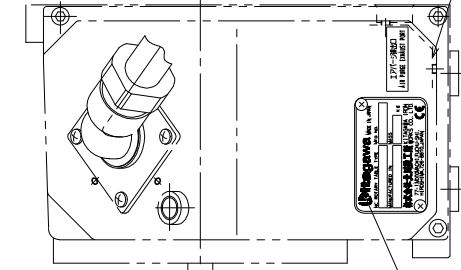


潤滑油供給口  
LUBRICATION PORT  
シールB  
(61E430246)

潤滑油排出口  
DRAIN PORT

シール  
SEAL  
(61E471576)

2-M5  
エアバーステータス出口  
AIR PURGE  
EXHAUST PORT  
シールM  
(61E445674)



Rc1/4  
クランプ用空圧供給口  
PNEUMATIC PORT FOR CLAMP  
シールA  
(61E448856)

ネームプレート  
NAME PLATE  
(61E474885)

製品名  
PRODUCT NAME

型式  
TYPE

製造日  
DATE OF MANUFACTURE

製造者所在地  
MANUFACTURE'S ADDRESS

製造機番  
MANUFACTURING NUMBER

製造者  
MANUFACTURER (KITAGAWA)

鉛番詳細  
DETAIL OF NAME PLATE

Kitagawa MADE IN JAPAN  
 NC ROTARY TABLE TYPE MFG NO.  
 MR160\*\* \* \* \* \* \*  
 MANUFACTURED IN MASS \* \* \* \* \* kg  
 株式会社北川鉄工所 KITAGAWA IRON WORKS CO., LTD.  
 77-1, MOTOMACHI, FUCHU-SHI, HIROSHIMA, 726-8610, JAPAN  
 CE

CAREER		SCALE	TYPE	MR160R00	WEIGHT	kg
MANAGER	CHIEF	1:3	NAME	NCテーブル NC ROTARY TABLE		
DRAWN BY S. SA TOH		3RD ANGLE		メイバン詳細図 DETAILS OF NAME PLATE		
KITAGAWA IRON WORKS CO., LTD.		DATE 12.07.26	DRW NO.	61E816446	1/1	

1 2 3 4 5 6





<http://www.mta.kiw.co.jp>

## KITAGAWA IRON WORKS CO., LTD.

77-1 Motomachi Fuchu-shi, Hiroshima-pref., 726-8610, Japan

TEL +81-847-40-0526 FAX +81-847-45-8911

America Contact	<b>KITAGAWA-NORTHTECH INC.</b> <a href="http://www.kitagawa.com">http://www.kitagawa.com</a> 301 E. Commerce Dr, Schaumburg, IL 60173 USA TEL +1 847-310-8787 FAX +1 847-310-9484
	<b>TECNARA TOOLING SYSTEMS, INC.</b> <a href="http://www.tecnaratools.com">http://www.tecnaratools.com</a> 12535 McCann Dr, Santa Fe Springs, California 90670 USA TEL +1 562-941-2000 FAX +1 562-946-0506
Europe Contact	<b>KITAGAWA EUROPE LTD.</b> <a href="http://www.kitagawaeurope.com">http://www.kitagawaeurope.com</a> Unit 1 The Headlands, Downton, Salisbury, Wiltshire SP5 3JJ, United Kingdom TEL +44 1725-514000 FAX +44 1725-514001
	<b>KITAGAWA EUROPE GmbH</b> <a href="http://www.kitagawaeurope.de">http://www.kitagawaeurope.de</a> Borsigstrasse 3, 40880, Ratingen Germany TEL +49 2102-123-78-00 FAX +49 2102-123-78-69
	<b>KITAGAWA EUROPE GmbH Poland Office</b> <a href="http://www.kitagawaeurope.de">http://www.kitagawaeurope.de</a> 44-240 Zory, ul. Niepodleglosci 3 Poland TEL +48 607-39-8855 FAX +48 32 -749- 5918
	<b>KITAGAWA EUROPE GmbH Czech Office</b> <a href="http://www.kitagawaeurope.de">http://www.kitagawaeurope.de</a> Lysicka 3, 621 00 Brno, Czech Republic TEL +420 603-856-122 FAX +420 549 -273- 246
Asia Contact	<b>KITAGAWA INDIA PVT LTD.</b> Lotus House East, Lane 'E' North Main Road, Koregaon Park, Pune, 411 001, Maharashtra, India TEL +91 20-6500-5981 FAX +91 20-2615-0588
	<b>KITAGAWA (THAILAND) CO., LTD. Bangkok Office</b> 9th FL, Home Place Office Building, 283/43 Sukhumvit 55Rd. (Thonglor 13), Klongton-Nua, Wattana, Bangkok 10110, Thailand TEL +66 2-712-7479 FAX +66 2-712-7481
	<b>KITAGAWA IRON WORKS CO., LTD. Singapore Branch</b> #02-01 One Fullerton, 1 Fullerton Road, Singapore 049213 TEL +65 6838-4318 FAX +65 6408-3935
	<b>KITAGAWA IRON WORKS (SHANGHAI) CO., LTD.</b> Room308 3F Building B. Far East International Plaza, No.317 Xian Xia Road, Chang Ning, Shanghai, 200051 China TEL +86 21-6295-5772 FAX +86 21-6295-5792
	<b>DEAMARK LIMITED</b> <a href="http://www.deamark.com.tw">http://www.deamark.com.tw</a> No. 6, Lane 5, Lin Sen North Road, Taipei, Taiwan TEL +886 2-2393-1221 FAX +886 2-2395-1231
Oceania Contact	<b>KITAGAWA KOREA AGENT CO., LTD.</b> <a href="http://www.kitagawa.co.kr">http://www.kitagawa.co.kr</a> 803 Ho, B-Dong, Woolim Lion's Valley, 371-28 Gasan-Dong, Gumcheon-Gu, Seoul, Korea TEL +82 2-2026-2222 FAX +82 2-2026-2113
	<b>DIMAC TOOLING PTY. LTD.</b> <a href="http://www.dimac.com.au">http://www.dimac.com.au</a> 61-65 Geddes Street, Mulgrave, Victoria, 3170 Australia TEL +61 3-9561-6155 FAX +61 3-9561-6705

The products herein are controlled under Japanese Foreign Exchange and Foreign Trade Control Act. In the event of importing and/or exporting the products, you are obliged to consult KITAGAWA as well as your government for the related regulation prior to any transaction.

2012.09.