

INSTRUCTION MANUAL

S type

HIGH SPEED ROTARY HYDRAULIC CYLINDER OPEN CENTER



DANGER

- This instruction manual is for production engineers and maintenance personnel in charge of operation of this product. When a beginner uses this product, receive instructions from experienced personnel, the distributor or our company.
- Before installing, operating or maintaining this equipment, carefully read this manual and the safety labels attached to the equipment. Failure to follow these instructions and safety precautions could result in serious injury, death, or property damage.
- Store this manual near equipment for future reference.
- If any questions related to safety arise about this manual, please confirm them with the distributor or our company.

KITAGAWA IRON WORKS CO., LTD.

77-1 Motomachi, Fuchu, Hiroshima 726-8610 Japan

TEL +81 847-40-0526

FAX +81 847-45-8911

Preface

This manual provides detailed information about how to safely and correctly use the cylinder (S type) for a lathe. Before starting to use this cylinder, read this manual carefully and always follow the instructions and warnings in "Important Safety Precautions" and "Precautions for Use" at beginning of the manual. Failure to follow these precautions could result in a serious accident.

Terms and Symbols Used for Safety Messages

In this manual, precautions for handling that are considered especially important are classified and displayed as shown below depending on the damage of risk including the seriousness of the harm that could result. Please sufficiently understand the meanings of these terms and follow the instructions for safe operation.

Safety Alert Symbol

The triangle is the safety alert symbol used to alert you to potential safety hazards that could result in injury or death.



Indicates a hazardous situation which, if you not avoided, will result in death or serious injury.



Indicates a hazardous situation which, if you not avoided, could result in death or serious injury.



Indicates a hazardous situation which, if you not avoided, could result in minor or moderate injury.



Indicates instructions which, if not avoided, could result in damage to the equipment or a shortened work life.

Liability and How to Use this Manual

This product is a hydraulic device to control the operation of power chuck installed on the lathes or rotary tables. For any other applications, please contact us.

Our company will not assume responsibility for injury, death, damage, or loss resulting from not following the instructions in this manual.

There are countless things that cannot or should not be done, and it is impossible to cover all of them in this manual.

Therefore, do not perform any actions unless they are specifically allowed in this manual. If any questions related to safety arise about operation, control, inspection and maintenance which are not specified in this manual, please confirm them with our company or distributor before performing them.

Guarantee and Limitation of Liability

The guarantee period of this product is 1 year after delivery.

Use the parts delivered by Kitagawa Iron Works for all the parts including consumable parts. We will not assume responsibility for injury, death, damage, or loss caused by usage of parts not manufactured by Kitagawa Iron Works. Additionally, if parts other than genuine parts manufactured by Kitagawa Iron Works are used, this guarantee will be completely invalid.

The chuck and cylinder from Kitagawa Iron Works should be used together. If you must use a part not made by Kitagawa, check with us or our distributor to be sure it is safe to do so. We will not be responsible for injury, death, damage or loss caused by use of a chuck or cylinder made by another company unless this use has been approved by Kitagawa or its distributor.

Table of Contents

1. Structural Drawing and Parts List	3
1-1. Type display	
1-2. Structural drawing	
1-3. Scope of product	
1-4. Parts list	
2.  Important Safety Precautions	6
3. Specifications	13
3-1. Specification table	
4. Hydraulic Oil	14
5. Trial Operation	15
6. Maintenance and Inspection	16
6-1. Maintenance and inspection of cylinder	
6-2. Maintenance and inspection of hydraulic unit	
6-3. List of seals to use	
7. Malfunction and Countermeasures	17
7-1. In the case of malfunction	
7-2. Where to contact in the case of malfunction	
8. Coolant Collector	18
8-1. Outline	
8-2. Type and applicable cylinder	
8-3. Specifications	
8-4. Attachment	
8-5. Positional adjustment of proximity switch	
8-6. Precautions	
8-7. Parts list	
For Machine Tool Manufacturers (Chapter 9)	
9. Attachment	21
9-1. Outline drawing of attachment	
9-2. Production and attachment of cylinder adapter	
9-3. Production and attachment of draw pipe	
9-4. Attachment of cylinder	
9-5. Tightening torque of cylinder attaching bolt	
9-6. Attachment of parts other than parts manufactured by Kitagawa Iron Works	
10. About Hydraulic Circuit Design	28
11. Other Information	29
11-1. About standards and orders	
11-2. Information about markings of product	
11-3. About disposal	

1 . Structural Drawing and Parts List

1-1 Type display

Type display as shown below.

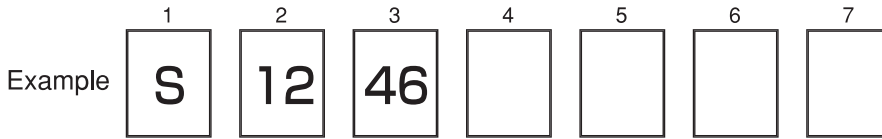

5th digit and after that are not displayed for the standard cylinders.

1. S Abbreviated name of S cylinders
2. 12 Nominal inside diameter of the cylinder
3. 46 Nominal thru-hole diameter
4. — Cylinder with lock valve, relief valve and fan (Standard specification)
- L Long stroke type cylinder with lock valve, relief valve and fan
- 5~7 Columns for special specification for each destination of delivery

Remarks 1) What is a “lock valve” ?

This is a valve which has a function to retain the hydraulic pressure inside a cylinder temporarily when the pump pressure suddenly lowers as a result of blackout, malfunction of the hydraulic pump, etc.

Remarks 2) What is a “relief valve” ?

This is a valve which has a function to stop damage when the hydraulic oil filled inside the cylinder has increased its pressure due to the volume change.

1-2 Structural drawing

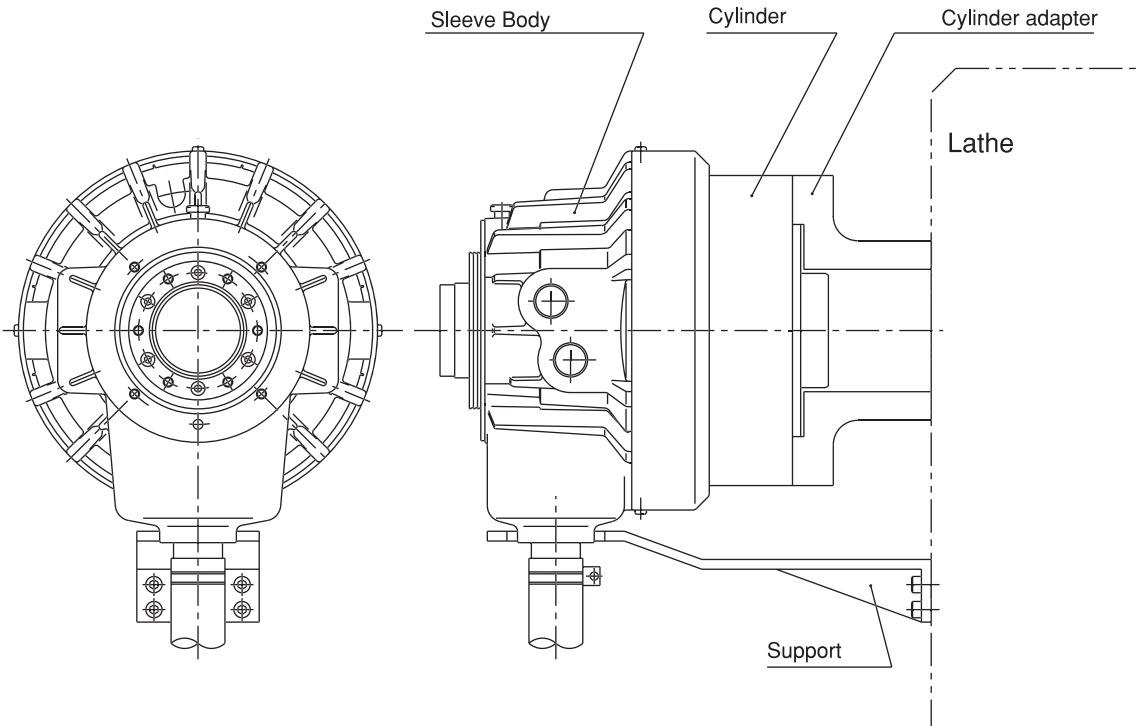

Fig. 1

1-3 Scope of product

This instruction manual is for the cylinder part.

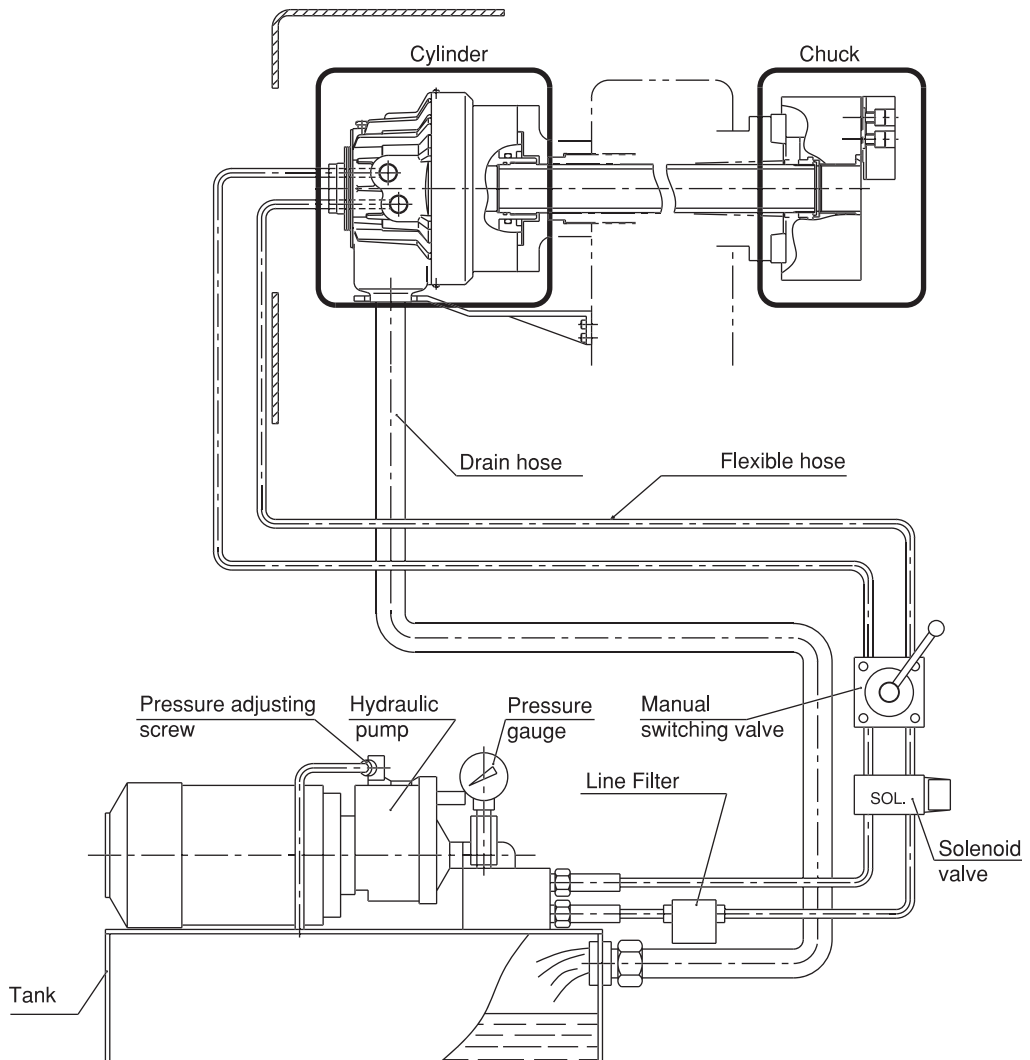

Fig. 2

WARNING

- To prevent the work from flying, safe design, maintenance and erroneous action prevention of the hydraulic system to maintain the gripping force of the chuck is extremely important. Thoroughly read the “Important Safety Precautions” on and after page 6 in this manual.
- As for the chuck, follow the instruction manual for the chuck.

1-4 Parts list

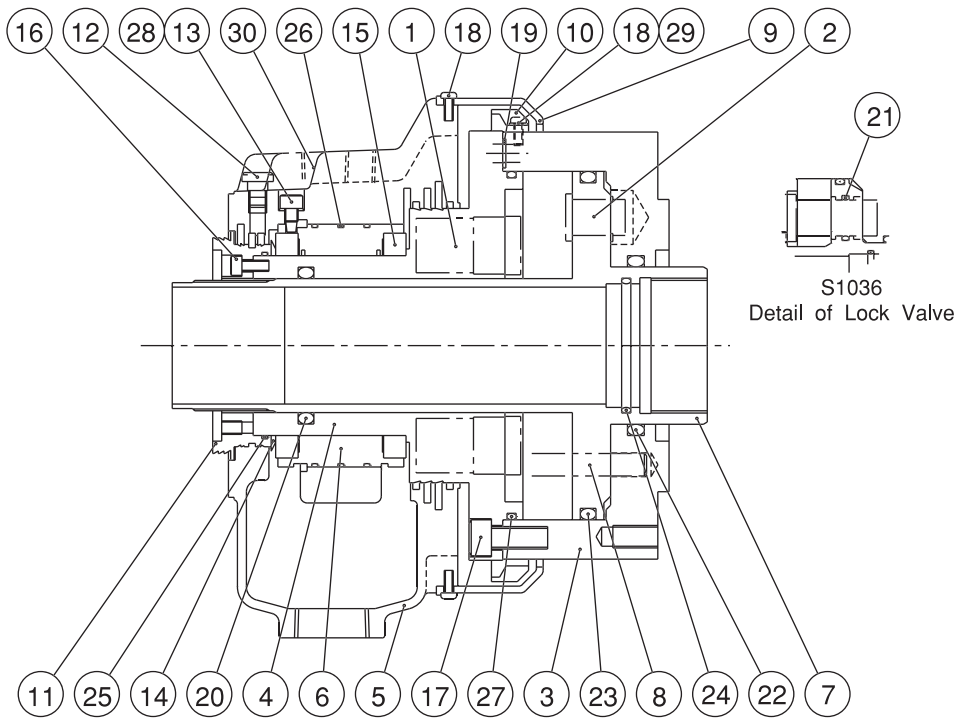

Fig. 3

Table 1

No.	Part name	Quantity	No.	Part name	Quantity
1	Lock valve	2 or 4	16	Socket head cap screw	6 or 12
2	Relief valve	2	17	Socket head cap screw	8 or 12 or 16
3	Cylinder	1	18	Cross-Recessed head Machine screw	7or 8or 12
4	Rotary valve	1	19	O-ring	0 or 1or 4
5	Sleeve body	1	20	O-ring	1 or 2
6	Sleeve	1	21	O-ring	0 or 2
7	Piston	1	22	O-ring	1
8	Guide pin	0 or 2	23	O-ring	1
9	Fan cover	1	24	O-ring	1
10	Fan	1	25	O-ring or Seat packing	1
11	Stopper	1	26	O-ring	3
12	Air breather	1	27	O-ring	1
13	Plug	1	28	Seal washer	1
14	Flinger	1	29	Plain washer	0 or 4
15	Bearing	2	30	Plug	2

2. Important Safety Precautions

Important safety precautions are summarized below. Please read this section before first starting to use this product.



DANGER

Failure to follow the safety precautions below will result in serious injury or death.



Turn off main power supply before attaching, inspecting or replacing cylinder, and before adding oil.

For All Users

- The cylinder may start rotation suddenly, and a part of the body or clothing may be caught.

Main power supply

OFF

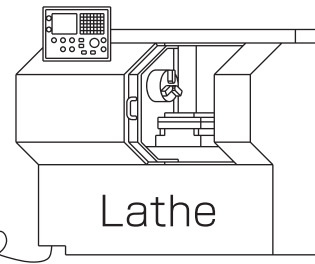
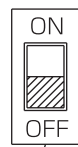

Lathe



Close door before rotating spindle.

For All Users

- If the door is not closed, you may touch the rotating chuck or the work may fly out, which is very dangerous. (In general, the safety interlock function which allows rotation only when the door is the manual mode or the test mode)

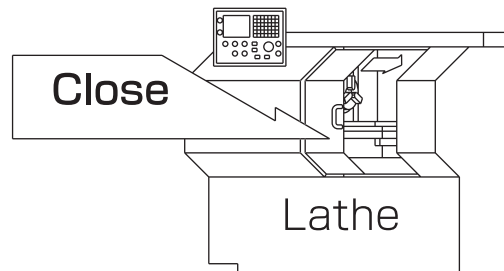

Close

Lathe



During spindle rotation, do not turn off hydraulic pump power supply and do not operate switching valve.

For All Users

- Cutting off hydraulic pressure causes a drop in the gripping force which could result in the work being released and flying out.
- Operating the manual switching valve or solenoid valve will lead to a drop of hydraulic pressure.

Manual switching valve

Jaw closed



Jaw open

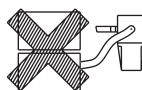

Solenoid valve

NO

Work

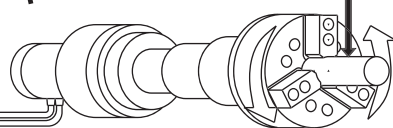



DANGER

Failure to follow the safety precautions below will result in serious injury or death.



Do not allow the rotation speed of the chuck to exceed the maximum allowable speed limit. **For All Users**

- If the rotation speed of the chuck exceeds the rotation speed limit, this is very dangerous as the chuck and work will fly out.

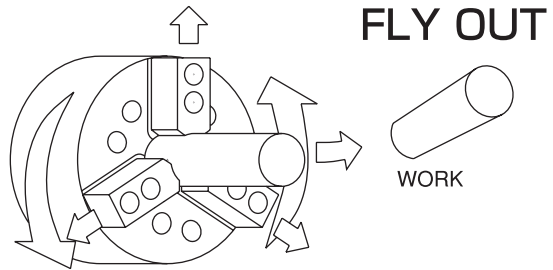

The input force of the chuck (piston thrust, pulling force of the draw pipe) must not exceed the allowable maximum input force. **For All Users**

- Input must match the specification of the chuck.
- Adjust the hydraulic pressure to the cylinder so that the input force, which determines the gripping force of the chuck, does not exceed.
- Excessive input force can lead to breakage of the chuck, which is very dangerous, as the chuck can work can be damaged and fly out.

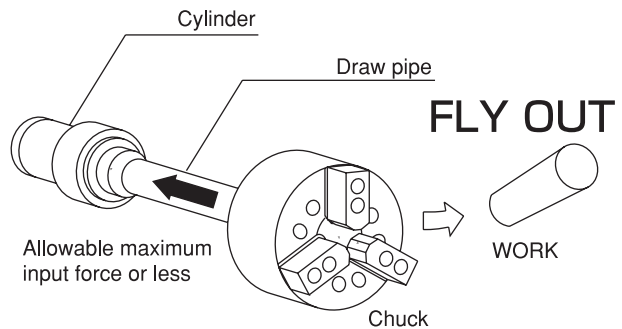

If you use the chuck with the inside diameter gripping, input force (hydraulic pressure) must be 1/2 or less of the allowable maximum input. **For All Users**

- The chuck may break and the chuck or work could fly out.

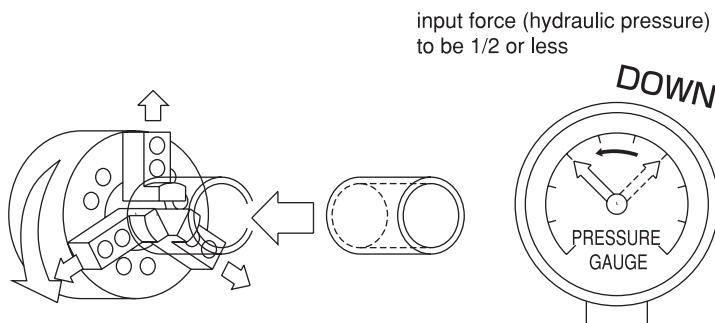



DANGER

Failure to follow the safety precautions below will result in serious injury or death.



Be sure cover is attached to periphery of cylinder before operating machine. (Refer to pages 21-22)

For All Users

- This will prevent the body or clothing from being caught in the machine.

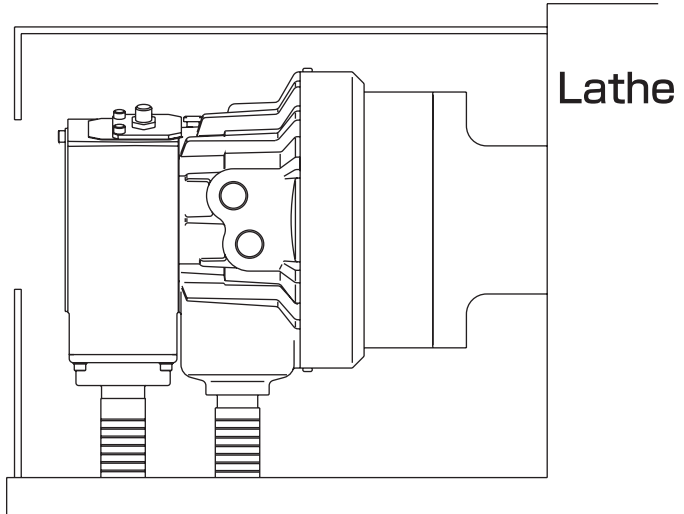

Prepare the covers that conform to the following standards.

- EN953
- EN ISO13857
- EN1088



Always tighten the bolts at the specified torque. (Refer to page 26)

For All Users

- If the torque is insufficient or excessive, the bolt will break, which is dangerous as the cylinder or work will fly out.
- Fix the lathe spindle or the cylinder when you tighten bolts. Your hand could slip and get injury when you work without fixing the spindle.
- You must use a torque wrench for torque control.

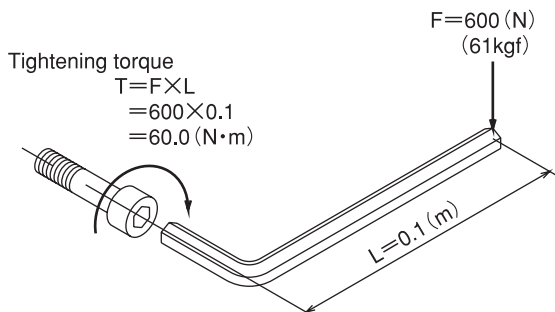
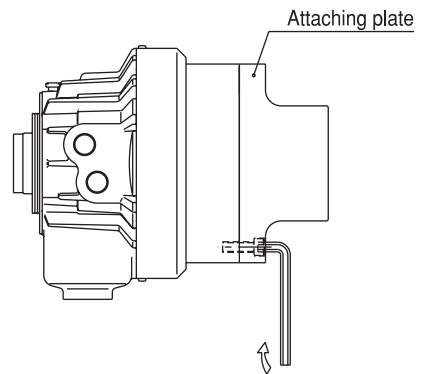

Tightening torque is moment of force when you tighten a bolt. Tightening torque = $F \times L$.

Specified torque for socket head cap screw

Bolt size	Tightening torque
M10	58 N · m
M12	85 N · m
M16	200 N · m

※ Since the material of the cylinder is aluminum, it is 80% of the tightening torque to the bolt size specified for the hydraulic chuck of our company.



DANGER

Failure to follow the safety precautions below will result in serious injury or death.



Use of a chuck and cylinder that cannot be used together safely may cause the cylinder to break at high pressure resulting in the chuck and work flying out.

For All Users

- Check that the chuck and the cylinder are in the “safe combination” when using at high pressure with our company or the distributor. Especially when the cylinder of our company and a high pressure chuck of other company are combined, confirmation is necessary.
- If one of the abnormal events shown below occurs during operation, immediately stop the machine and consult with our company or the distributor.
 - The work slips.
 - Loss of accuracy.
 - The work begins to chatter.
 - The machine's vibration significantly increases.
 - The gripping force does not rise even if hydraulic pressure is raised.

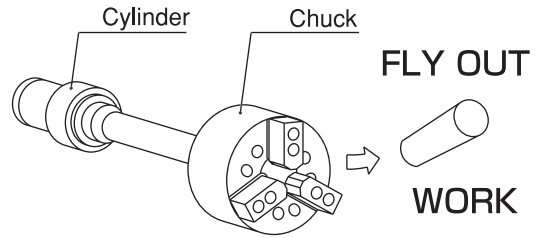

Use a cylinder with a lock valve (safety valve, check valve) incorporated in case of sudden hydraulic pressure drop due to blackout, malfunction of the hydraulic pump, etc. Further, use a solenoid valve with a circuit that retains the gripping position when no current is carried.

For Machine Tool Manufactures

- If the hydraulic pressure suddenly drops due to blackout or malfunction of the hydraulic pump, etc., this is dangerous as work will fly out.
- Lock valve retains the hydraulic pressure inside the cylinder temporarily, when the hydraulic pressure suddenly drops due to blackout or malfunction of the hydraulic pump, etc.

Lightning
= Blackout

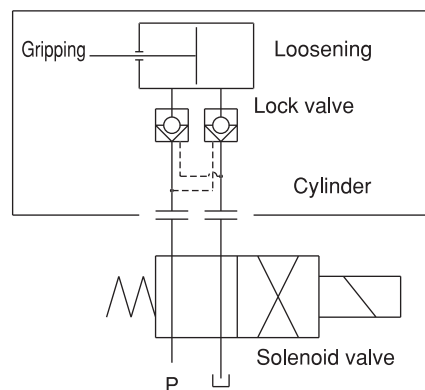
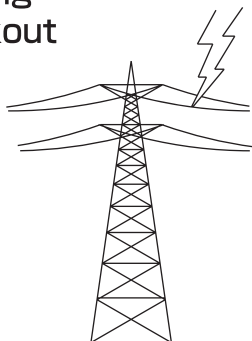

The gripping position must be retained.



DANGER

Failure to follow the safety precautions below will result in serious injury or death.



- Provide sufficient strength for the draw pipe (Refer to pages 23-24).
- Provide sufficient screw depth for the draw pipe.
- Firmly tighten the draw pipe.
- Apply adhesive to the thread part of the draw pipe and screw it in at the specified torque.

For Machine Tool Manufactures

- If the draw pipe break, the gripping force is instantly lost and this is dangerous as work will fly out.
- If the screw depth of the draw pipe is insufficient, the screw will break and the gripping force will be lost instantly, and this is dangerous as work will fly out.
- If the draw pipe is unbalanced, excessive vibration could occur breaking the screw and resulting in the gripping force being lost and the work flying out.
- When screwing the draw pipe, piston to the end of the pressing side stroke.
- If the engagement of the screw of the draw pipe is loose, vibration may occur resulting in breakage of the screw. If the screw breaks, the gripping force will be lost instantly, which is dangerous as the work will fly out.
- When the screw is loosened, the jaw stroke of the chuck becomes shorter and this is very dangerous as the work will fly out.

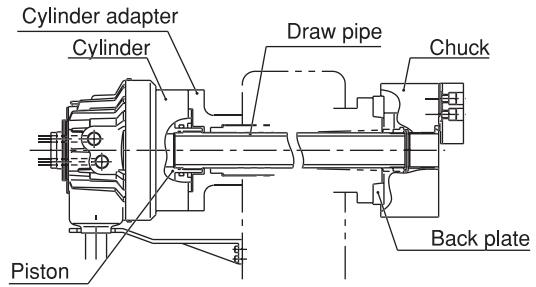

Type	Tightening torque	Type	Tightening torque
S1036	100 N·m	S1875 · S1875L	340 N·m
S1246·S1246L	150 N·m	S2091 · S2091L	380 N·m
S1552·S1552L	280 N·m	S2816	800 N·m

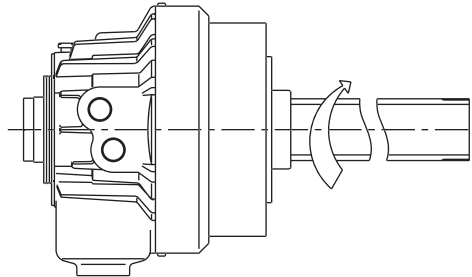

WARNING

Failure to follow the safety precautions below could result in serious injury or death.



Do not modify the cylinder.

For All Users

- Doing so may damage the cylinder and cause oil leakage which could result in a fire. And if the hydraulic oil leaks, the gripping force of the chuck will lower and the work may fly out, which is dangerous.
- Do not attach additional machining such as screws.
- Do not detach parts of the cylinder from the cylinder.



Do not rotate the cylinder without hydraulic pressure.

For All Users

- Doing so could cause seizing inside the cylinder, leading to a drop in the gripping force of the chuck. This is dangerous as work will fly out.



WARNING

Failure to follow the safety precautions below could result in serious injury or death.



Periodically add hydraulic oil.
Turn off power and use designated hydraulic oil.
(Refer to page 14)

For All Users

- If supplying of the hydraulic oil is insufficient, the operation speed may lower and the thrust force will become insufficient resulting in a drop in the gripping force of the chuck, which is dangerous as the work may fly out.
- Use abrasion resistant and deforming hydraulic oil.

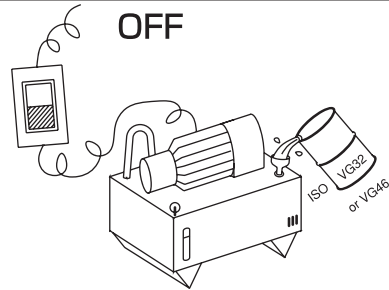

Assemble piping after completely removing the dust inside the pipe.
Add a filter into the pressure supplying line.

For All Users

- Failure to do so could cause oil leakage and may result in a fire.
- Maintain the function of the incorporated lock valve and relief valve, and prevent seizing due to foreign matter.
- If the function of the lock valve lowers, this is dangerous as the work will fly out when the hydraulic pressure suddenly lowers due to blackout or malfunction of the hydraulic pump, etc.
- If the function of the relief valve lowers, the volume of the filled hydraulic oil changes causing an increase in pressure, which is dangerous resulting in malfunction.
- If seizing is caused by foreign matter, the gripping force of the chuck will lower, which is dangerous as the work will fly out.

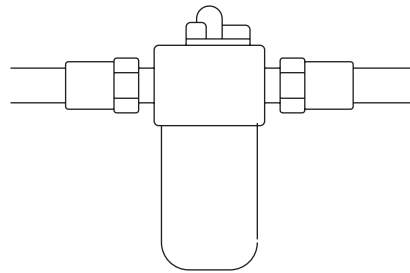

Filtering
Precision
20 μ m or
less



Do not operate the machine after drinking alcohol or taking medication.

For All Users



Do not operate the machine wearing gloves, a necktie, and other loose clothing or jewelry.

For All Users

- Dangerous since these lead to operation mistakes and misjudgment.

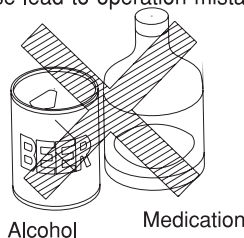

Alcohol

Medication

- Dangerous since it will be caught.





WARNING

Failure to follow the safety precautions below could result in serious injury or death.



Refer to page 27 in this manual when you attach the other than parts manufactured by Kitagawa Iron Works (a stopper to shorten stroke or spindle work stop, etc.) to the cylinder. However, the personnel who designed those parts must judge whether they are safe for the usage conditions.

For Machine Tool Manufactures

- Doing so may damage the cylinder and cause oil leakage which could result in a fire. And if the hydraulic oil leaks, the gripping force of the chuck will lower and the work may fly out, which is dangerous.

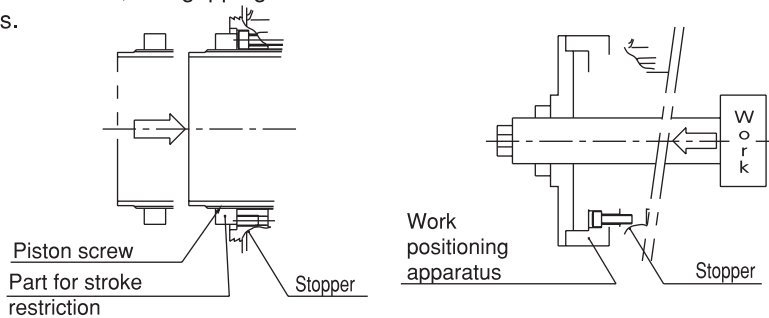

Do not attach the cylinder vertically.

For Machine Tool Manufactures

- It will cause oil leakage and may result in a fire.

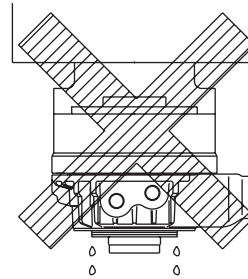

3. Specifications

3-1 Specifications table

Table 2

Type	S1036	S1246	S1552	S1875	S2091	S2816	S1246L	S1552L	S1875L	S2091L
Thru-hole diameter mm	36	46	52	75	91	165	46	52	75	91
Piston stroke mm	15	15	22	25	30	30	32	34	40	50
Piston surface area (pulling side) cm ²	64	89	150	183	234	332	89	150	183	234
Piston maximum thrust force kN	24	33	56	69	88	91	33	56	69	88
Maximum operating hydraulic pressure MPa	4.0	4.0	4.0	4.0	4.0	3.0	4.0	4.0	4.0	4.0
Maximum rotation speed min ⁻¹	8000	7000	6200	4700	3800	1700	7000	6200	4700	3800
Mass kg	8.6	12.0	16.8	26.0	33.0	84.0	12.8	17.0	26.8	34.1
Moment of inertia Kg · m ²	0.011	0.019	0.053	0.095	0.153	0.698	0.022	0.058	0.100	0.160
Drain amount ℓ / min	3.0	3.0	3.9	4.2	4.5	8.4	3.0	3.9	4.2	4.5
Balance quality	G6.3									
Storing temperature / Operating temperature	-20~+50℃ / -10~+40℃									

Note 1) The drain amount is a value when the hydraulic pressure is 3.0 MPa, and the oil temperature is 50℃.

Note 2) How to obtain the piston thrust force

$$\begin{array}{l} \text{Operating} \\ \text{Piston} \\ \text{thrust force} \\ \text{(kN)} \end{array} = \begin{array}{l} \text{Piston} \\ \text{Maximum} \\ \text{Thrust force} \\ \text{(kN)} \end{array} \times \frac{\begin{array}{l} \text{Operating} \\ \text{hydraulic pressure(MPa)} \end{array} - 0.25}{\begin{array}{l} \text{Maximum operating} \\ \text{hydraulic pressure(MPa)} \end{array} - 0.25}$$

Note 3) When storing this product, the product should be subjected to the antirust treatment and stored in a place free from wetting, condensation, or freeze.

4 . Hydraulic Oil

- To keep good operation of the cylinder, it is recommended to use hydraulic oil with a viscosity of 30-50cSt at 40°C. (ISO VG32 VG46 equivalent product)
- Replace the hydraulic oil about once every six months.
- The characteristics of hydraulic oil influences the heating, drain amount and acting speed of the cylinder, therefore, control it according to the instruction manual for the hydraulic unit.

WARNING

- Turn off the power source and supply designated hydraulic oil. Insufficient oil supply decreases the acting speed, causes thrust force insufficiency resulting in a drop in the chuck gripping force, which could allow the work to fly out. Use abrasion resistant and deforming hydraulic oil. Add a filter of 20 μm or less in the pressure supply line to maintain the function of the cylinder and to prevent seizing caused by foreign matter.

NOTICE

- If high speed rotation is continued, the oil temperature will rise, which could rapidly a high temperature, it will rapidly aggravate deterioration of the sealing materials and deterioration of the hydraulic oil. Use a cooler to keep the oil temperature at 60°C or lower.

<Example>

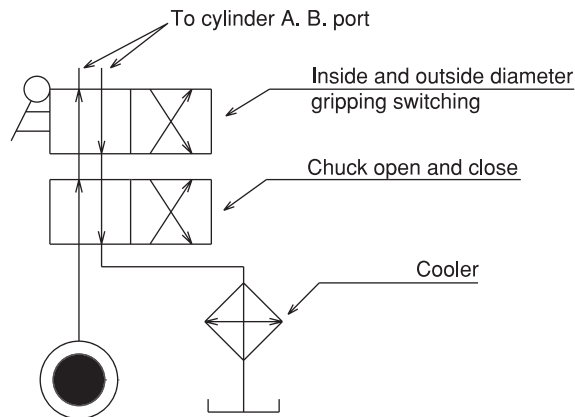

Fig. 4

※ Keep the back pressure extremely low in this case as well.

Safety information about hydraulic fluid and anti-rust oil

Applicable range

- Hydraulic fluid sealed in the product at the delivery.
- Antirust agent applied to the product at the delivery.

First aid measures

After inhalation: Remove victim to fresh air. If symptoms persist, call a physician.

After contact with skin: Wash off with mild cleaners and plenty of water. If symptoms persist, call a physician.

After contact with eyes: Rinse with plenty of water. If symptoms persist, call a physician.

After ingestion: If large amounts are swallowed, do not induce vomiting. Obtain medical attention.

- Please refer to each MSDS about the hydraulic fluid and the anti-rust oil which you prepared.

5 . Trial Operation

Read safety precautions starting on page 6 before performing trial operation.

- (1) Check that the power voltage is at the specified voltage.
- (2) Set the pressure adjusting handle to the lowest state during trial operation, and check the turning direction of the pump in inching (shortly turn on and off the switch). When it is rotating in the reversed direction, change the connection of 2 cables out of the 3 cables.
- (3) As for the operating pressure for chucking, first lower to the lowest pressure, and then set to low pressure at which the chucking action is possible (0.35-0.5MPa) to check the following.
 - Is it operating smoothly?
 - Is the operating direction correct? (Opening and closing direction of the chuck)
 - Is the operating stroke appropriate? (Jaw stroke of the chuck)
 - Is there any oil leakage with each piping?If they are normal, gradually raise the operating pressure up to the rated pressure while checking the items specified above.

At this point, check that the drainage is flowing smoothly.
- (4) Rotate the lathe spindle by setting the rotation speed to the minimum. If there is no run-out of the cylinder or no abnormalities in the support and piping, gradually raise the rotation speed.

If the rotation vibration is too excessive, run-out of the adapter must be inspected again.
- (5) If the oil temperature is low (20-30°C) or less, run it in at about 1/3 of the maximum rotation speed.

NOTICE

- When the ambient temperature of the cylinder suddenly rises, for example, thermal effect is received from heating of the pulley, etc., or when there is a special heat generation source around the cylinder, the cylinder charged pressure rises and then the cylinder may stop operation, if it is continuously operated for a long period of time without switching operation, since a lock mechanism is built in such a phenomenon occurs more frequently especially at the time of running in, therefore, frequently reciprocate the piston.

<Treatment when the cylinder cannot be operated>

- Regardless of trial operation or normal operation, when the cylinder cannot be operated, try the operations specified below.
 1. When the lathe spindle is rotating, stop rotation.
 2. Turn the pressure adjusting handle of the pressure regulation valve for the chuck setting pressure (cylinder setting hydraulic pressure) at the hydraulic unit part, and raise the chuck setting pressure for about 0.5 MPa and repeat switching over the operation selecting switch of the cylinder to check the operation of the cylinder.
 3. If the operation inability still continues, raise the chuck setting pressure additionally (about 0.5 MPa at a time), and repeat the operation in the same manner as item (2), to check the action of the cylinder. In this case, the limit of the pressure raising is up to 30% increase of the maximum operating hydraulic pressure.

When the cylinder operation is recovered, bring back the preset chuck pressure to the normal level.
 4. If the cylinder cannot be operated even after the chuck setting pressure is raised to the maximum and the operation specified in the above item (3) is repeated several times, return to the chuck setting pressure, turn off the power supply, cool down the temperature of the cylinder surface to be almost the same as the room temperature, and then repeat the operations specified in the above items (2) and (3) to check the operation of the cylinder.

The cylinder can be cooled down more quickly by forcibly blowing air to the cylinder using an air gun, etc.
 5. If the cylinder cannot be operated even after cooling down, loosen the draw nut on the chuck side and remove the connection, and then check the operation of the cylinder.

<Usage>

This product is a hydraulic device to control the operation of power chuck installed on the lathes or rotary tables. The piston moves forward and backward by supplying hydraulic pressure to the cylinder. By this, the linked jaws of the power chuck move toward the closing side to grip the workpiece, so that the workpiece is clamped during the machining. After the machining, the jaws move toward the open side to allow the workpiece to be removed.

6 . Maintenance and Inspection

6-1 Maintenance and inspection of the cylinder

If any malfunction occurs, return cylinder to our company for repair. If it is disassembled and reassembled at a place other than our company, it may not function correctly as well as cause precision failure.

6-2 Maintenance and inspection of hydraulic unit

- Clean the suction strainer every 2 to 3 months.
- Replace the hydraulic oil about once every six months.

WARNING

- To avoid serious injury from flying work, use the throttle valve to keep the surge pressure low. Operation failure and cylinder breakage may occur if a reducing valve used for the hydraulic pressure setting fails to respond to pressure adjustment and results in excessive surge pressure.

6-3 List of seals to use (Refer to Fig.3)

Table 3

No.	Part name	S1036	S1246·S1246L	S1552·S1552L	S1875·S1875L	S2091·S2091L	S2816	Quantity
19	O-ring	—	JIS B2401 P8	JIS B2401 P10	JIS B2401 P10	JIS B2401 P10	JIS B2401 P10	1 or 4
20	O-ring	JIS B2401 G45	JIS B2401 P53	JIS B2401 P60	JIS B2401 P85	JIS B2401 P100	JIS B2401 G175	1 or 2
21	O-ring	JIS B2401 P16	—	—	—	—	—	2
22	O-ring	JIS B2401 P48	JIS B2401 P65	JIS B2401 P70	JIS B2401 P95	JIS B2401 P110	JIS B2401 P190	1
23	O-ring	JIS B2401 G100	JIS B2401 G120	JIS B2401 P145	JIS B2401 G170	JIS B2401 G195	JIS B2401 G270	1
24	O-ring	NOK S38	JIS B2401 G50	JIS B2401 G55	JIS B2401 G80	JIS B2401 G95	JIS B2401 G170	1
25	O-ring	NOK S60	NOK S70	NOK S80	NOK S105	61R416203	61R421518	1
26	O-ring	NOK S80	NOK S95	NOK S105	JIS B2401 G135	JIS B2401 G150	JIS B2401 G250	3
27	O-ring	S102	JIS B2401 G120	AS 568-256	AS 568-261	AS 568-265	JIS B2401 G270	1

7 . Malfunction and Countermeasures

7-1 In the case of malfunction

Check the points specified below again and take measures.

Table 4

Defective	Measures
Piston Operation Inability	Check that the hydraulic pressure is operating by the motion of the flexible hose, etc.
	Check that there are no mistakes in piping.
	Try operations when operation inability specified in the items of the trial operation.
Cylinder Thrust Force Insufficiency	Check that the pressure is as specified at the cylinder pipe inlet by attaching a pressure gauge near the inlet of the cylinder.
	Wearing of the O-ring inside is possible when the flow rate of the returning side pipe or the drain is more than usual.
Temperature Rise	Check that the viscosity of the hydraulic oil is as designated.
	Replenish the hydraulic oil inside the tank if it is low.
	When the room temperature is high and the radiation effect of the tank is bad, control the oil temperature using a cooler or a fan, etc.
Pump noise	Do not suck air.
	Replenish the hydraulic oil inside the tank if it is low.
	If a large amount of dirt is deposited inside the tank, or when the hydraulic oil is deteriorated, the pump may be worn out abnormally, and it will be necessary to repair the pump.
Oil leakage from labyrinth	Provide a stream slope, without air pockets, and no back pressure must be applied.
	Return the drainage onto the surface of the oil of the hydraulic unit .
	Check that the air breather of the hydraulic unit is not clogged.



- If the chuck failed due to a seizure or breakage, remove the chuck from the machine, following the disassembly steps in the chuck instruction manual, and then remove the cylinder by the reverse steps of "9. Attachment" after page 21. When the jaws and covers cannot be removed due to a blockage of workpiece, do not disassemble forcibly but please contact us or our agent.
- If these countermeasures do not correct the problem or improve the situation. Immediately stop using the machine. Continuous use of a broken product or a defective product may cause a serious accident by the cylinder or the work flying out.
- Only experienced and trained personnel should do repairs and fix malfunctions. Repair of a malfunction by a person who has never received instruction from an experienced person, the distributor or our company may cause a serious accident.

7-2 Where to contact in the case of malfunction

In the case of malfunction, contact the distributor where you purchased the product or our branch office listed on the back cover.

8 . Coolant Collector

8-1 Outline

- The coolant collector is attached to the Kitagawa S type rotation hydraulic cylinder, and easily collects the coolant flowing inside the draw pipe.
- To electrically check piston operation and for clamping/unclamping detection of a work, There are 2 proximity switches attached to the coolant collector.

8-2 Type and applicable cylinder

- The coolant collector is to be arranged separately from the cylinder, so designate the type specified below when necessary.
- There are 2 proximity switches attached on the coolant collector, therefore, the cylinder operation can be checked.

Table 5

Type	Applicable cylinder	Type	Applicable cylinder
CSS10BN	S1036	CSS18BN	S1875, S1875L
CSS12BN	S1246, S1246L	CSS20BN	S2091, S2091L
CSS15BN	S1552, S1552L	CS-28SW	S2816

8-3 Specifications

- The standard specification of the proximity switch is BES516-329-E3R (B&PLUS) . Contact us if a specification other than the standard one is necessary.

Table 6

Type	BES516-329-E3R (B&PLUS)
Voltage	12/24V DC
Leakage current	200mA or less
Operation style	NPN

Table 7

Type	BES516-329-E3R (B&PLUS)
OP2	BLACK
+V	BROWN
0V	BLUE
OP1	BROWN

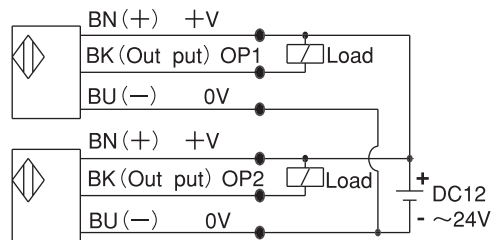

Fig. 5

8-4 Attachment

- Insert a sheet packing between the coolant collector main body and the sleeve body at the cylinder rear end, and attach the coolant collector to the cylinder rear end.
- After attaching the coolant collector, attach the detectable plate to the piston.
- To easily collect the coolant flowing into the coolant collector, provide appropriate slope to the piping, so that the coolant does not stagnate inside the hose. To check the flow, use a transparent vinyl hose. (Inside diameter $\phi 32$) (Fig. 6)

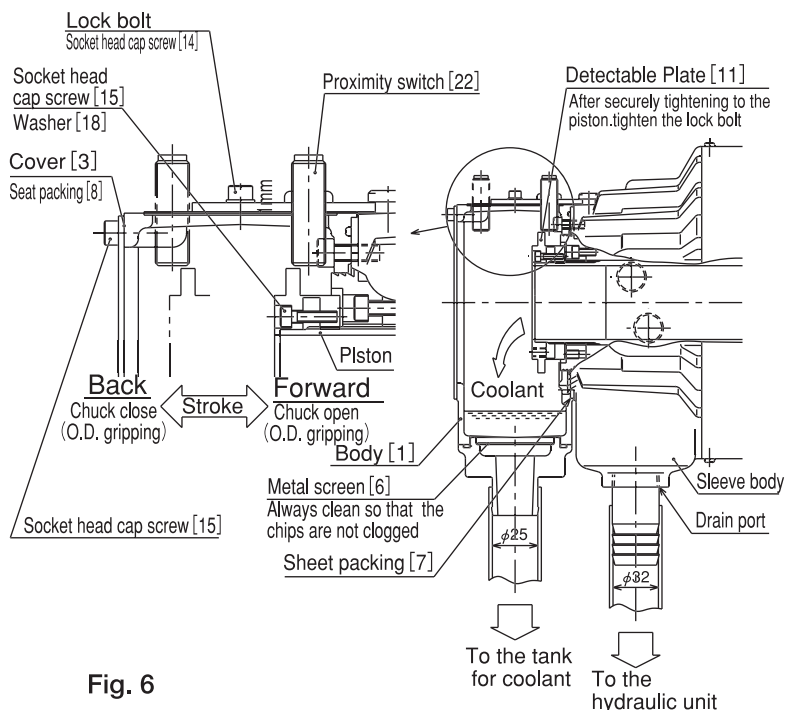

Fig. 6

8-5 Positional adjustment of proximity switch

Read following instruction when you adjust the proximity switch. (Fig.6)

- ① Loosen the socket head cap screw [15] on the coolant collector, then remove the cover [3] and the seat packing [8].
- ② Loosen the socket head cap screw [15] that fix the adjusting plate [4].
- ③ Unclamp the chuck.
- ④ Install one proximity switch [22] on the outer surface of the body [1], passing through the adjusting plate [4], and make it approach to the detectable plate [11] until the LED of proximity switch lights up. At this time, adjust the screw of proximity switch [22] so that the distance between proximity switch [22] and outside diameter end of detectable plate [11] is about 1 mm, and slide to adjust the adjusting plate [4] in the axial direction.
- ⑤ Tighten the socket head cap screw [15] to fix the adjusting plate [4].
- ⑥ Grip the workpiece.
- ⑦ For another proximity switch proceeds in the same way as it is described from point 4 and 5.
- ⑧ Confirm whether LED lights up by opening and closing the chuck several times.
- ⑨ Tighten the socket head cap screw [15] to fix the cover [3] and the seat packing [8].

8-6 Precautions

NOTICE

- If the coolant overflows from the coolant collector, the coolant is flows to the sleeve body side. Always clean the punching metal so that the coolant does not stagnate inside the coolant collector. Be sure the chips are not clogged. (Fig. 6)
- Loose the socket head cap screw [16] and turning the hose nipple by about 15° to left when you remove the hose nipple [5]. (Refer to page 20)

8-7 Parts list

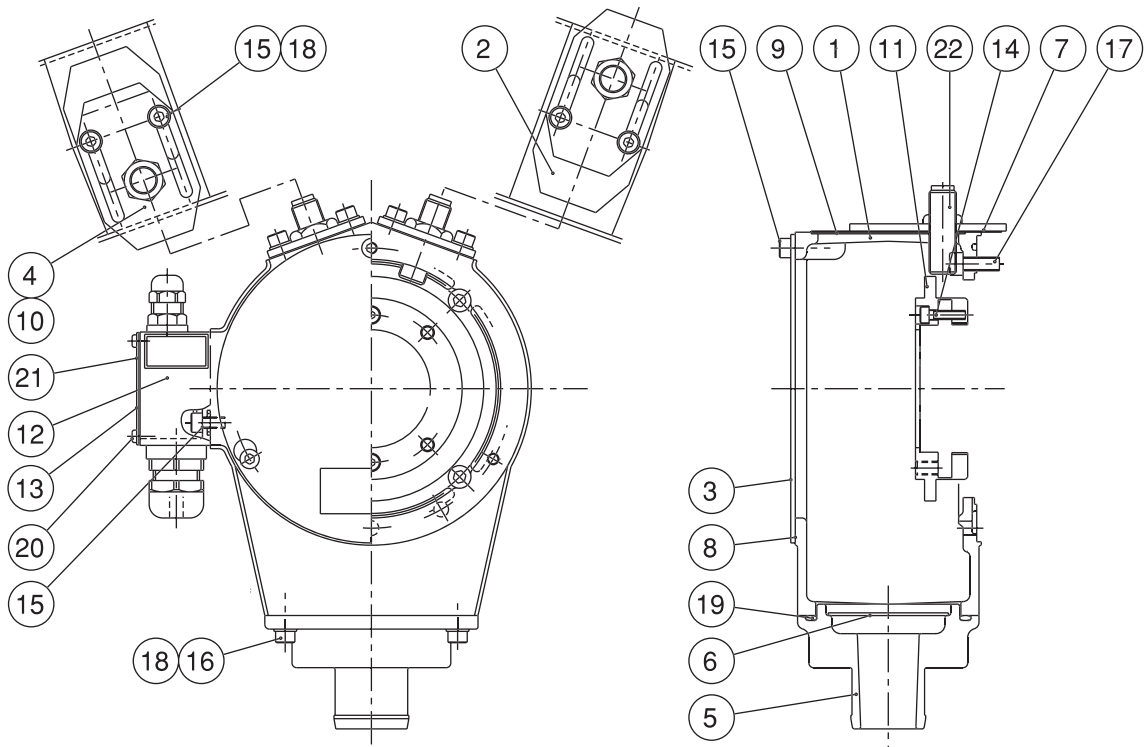

Fig. 7

Table 8

No.	Part name	Quantity	No.	Part name	Quantity
1	Body	1	13	Cover	1
2	Plate	2	14	Socket head cap screw	2
3	Cover	1	15	Socket head cap screw	9
4	Adjusting plate	2	16	Socket head cap screw	4
5	Hose nipple	1	17	Socket head cap screw	4
6	Metal screen	1	18	Plain washer	8
7	Sheet packing (1)	1	19	O-ring	1
8	Sheet packing (2)	1	20	Cross recessed head tapping cap screw	4
9	Sheet packing (3)	2	21	Sheet packing	1
10	Sheet packing (4)	2	22	Proximity switch	2
11	Detectable plate	1		BES516-329-E3R	
12	Terminal block assembling	1		Direct current 3 wire system a contact	

For Machine Tool Manufacturers

Following pages are described for machine tool manufacturers (personnel who attach a cylinder to a machine). Please read following instruction carefully when you attach or detach a cylinder to machine, and please sufficiently understand and follow the instructions for safe operation.

9 . Attachment

9-1 Outline drawing of attachment

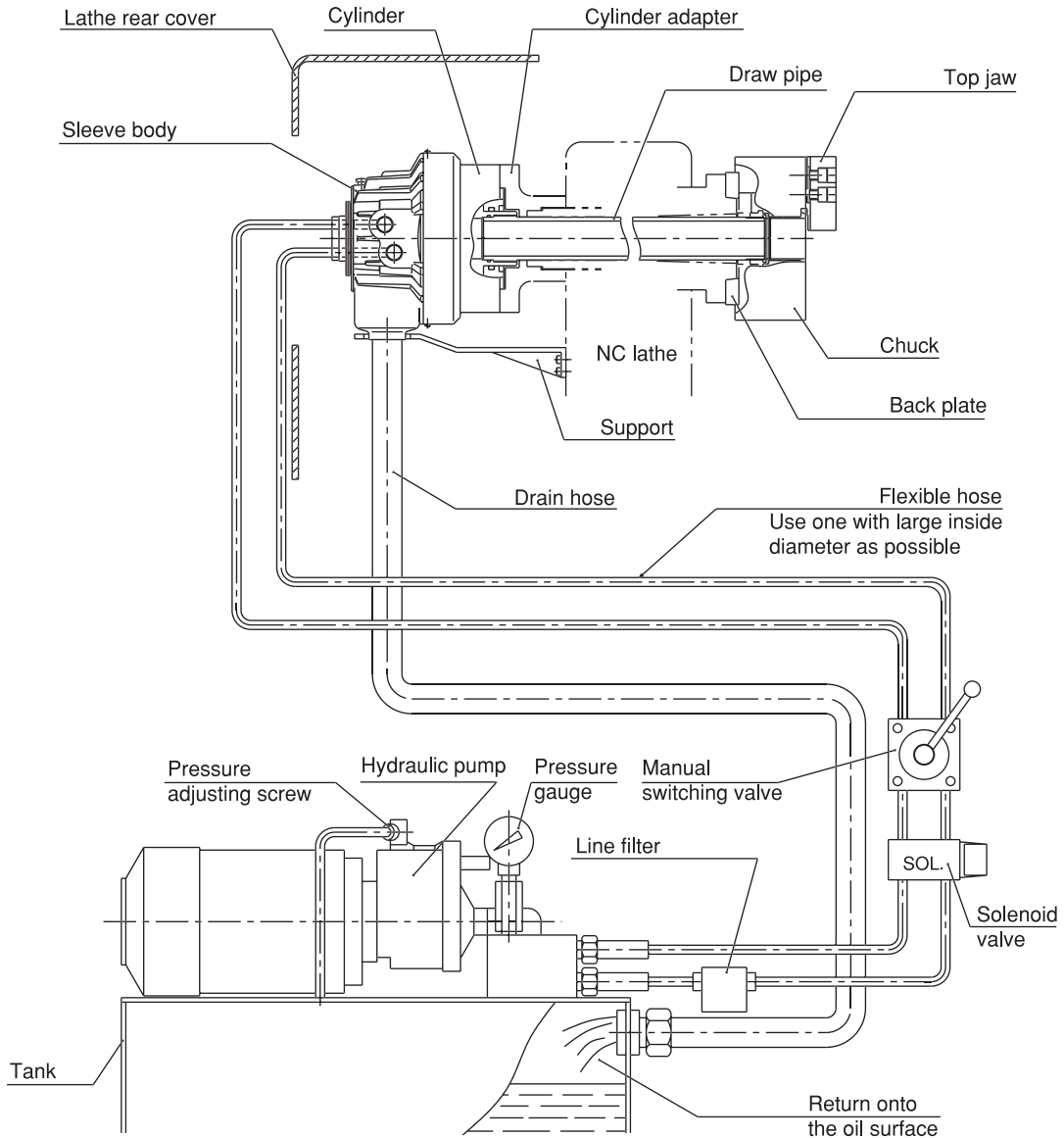

Fig. 8

- Attach the manual switching valve at a position where it is easy to operate for the attaching equipment.
- Install the hydraulic unit at a position where the drain hose is not kinked and the needle of the pressure gauge is easily read.
- Use a pipe inside diameter as large as possible.

⚠ DANGER

- When other actuators are operated by the same hydraulic pressure source as the cylinder for chuck, be sure that a pressure drop of the cylinder does not occur during use. A hydraulic pressure drop leads to a drop in the gripping force which could allow the work to fly out.
- As to the drain hose
 - Use one with inside diameter $\phi 32$.
 - Use a transparent vinyl hose for visualization.
 - Provide a stream slope, without air pocket. This will ensure no back pressure.
 - The end of the hose is physically above the oil level. (Refer to Fig.8)
- If the hydraulic oil stagnates inside the cylinder, oil leakage occurs, which may cause a fire.

⚠ WARNING

- Install after removing the dust inside the pipe completely.
- Add a filter to the pressure supply line. If foreign matters gets inside the cylinder, this is dangerous since the rotation valve of the cylinder will seize, the hose will tear off, and the cylinder will rotate. This is also dangerous as the work will fly out.
- Always use a flexible hose for the hydraulic piping to the cylinder, and the bending force or tensile force of the pipe must not be applied to the cylinder. Use a pipe inside diameter as large as possible and keep the piping length as short as possible.

NOTICE

- Provide an air passage behind the cylinder or a window the size of the sleeve body on the lathe rear cover for the hot air generated from the cylinder to escape to the outside.

9-2. Production and attachment of cylinder adapter

NOTICE

- Attach with the surface run-out of the cylinder adapter and the run-out of the spigot joint at 0.005 mm or less. (Fig. 10) Large run-out causes vibration and shortens the life of the cylinder significantly.

- Bring the cylinder as close to the lathe spindle support as possible. The attaching method of the cylinder adapter and the measuring method of run-out are illustrated in the drawings below. (Fig. 9, Table 9)
- Never fail to provide a setscrew to prevent loosening of the cylinder adapter. (Fig. 10)

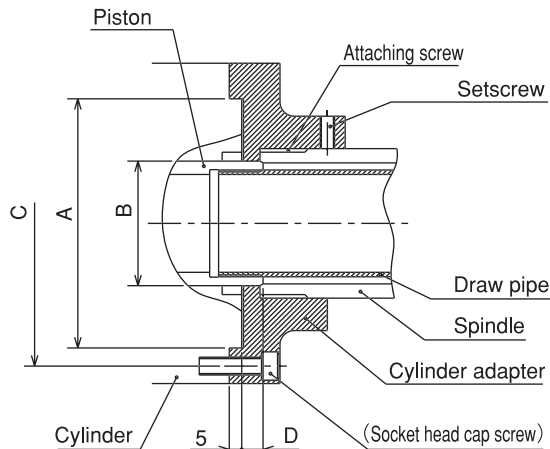

Cylinder adapter attaching part

Fig. 9

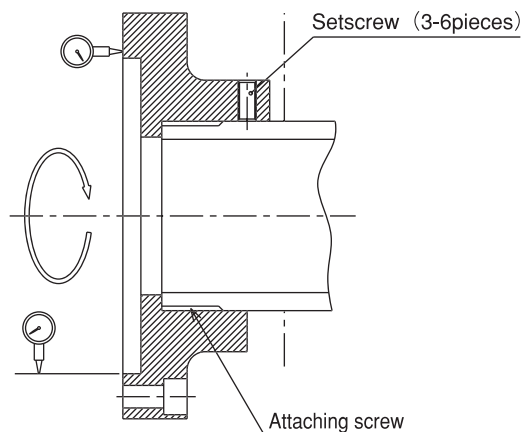

Run-out measurement of the cylinder adapter

Fig. 10

Table 9

(Unit: mm)

Type	φA (F7)	φB	φC	D (MAX)	Socket head cap screw
S1036	100	48	115	10	6-M10
S1246	100	65	130	10	12-M10
S1552	130	70	170	17	12-M10
S1875	160	95	190	20	12-M10
S2091	180	110	215	25	12-M12
S2816	260	190	290	25	12-M16
S1246L	100	65	130	22	12-M10
S1552L	130	70	170	24	12-M10
S1875L	160	95	190	30	12-M10
S2091L	180	110	215	40	12-M12

9-3 Production and attachment of draw pipe

- Determine the length of the draw pipe as shown below.
- When screwing the draw pipe into the piston, screw in a state that the piston fully comes outside.



- Sufficiently degrease and apply adhesive on the thread part of the piston and the thread part of the draw pipe, and then screw in and tighten.
- If the screw is loose, the jaw stroke of chuck will shorten, which could allow the work to fly out.

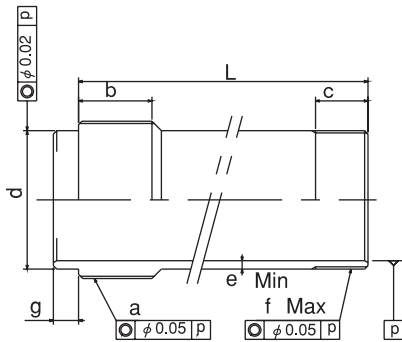

Fig. 11

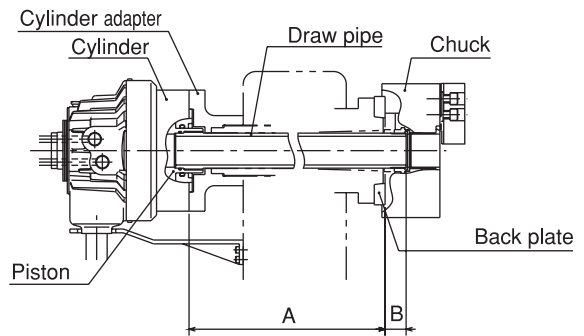

Fig. 12

Table 10

Type	Chuck	a	b	c	d (f7)	e Min	f Max	g	L	Note	
S1036	B-205	M42×1.5	25	25	38	-0.025 -0.050	3.5	M40×1.5	12	A+B+10	B-205 L=A+28
S1246	B-206	M55×2	30	25	50	-0.025 -0.050	5	M55×2	12	A+B+15	B-206 L=A+41
S1552	B-208	M60×2	30	25	55	-0.030 -0.060	4	M60×2	12	A+B+8	B-208 L=A+39
S1875	B-210	M85×2	35	30	80	-0.030 -0.060	5	M85×2	12	A+B+10	B-210 L=A+38.5
S2091	B-212	M100×2	35	35	95	-0.036 -0.071	4.5	M100×2	12	A+B+5	B-212 L=A+36
S2816	B-24	M180×3	45	42	170	-0.043 -0.083	7.5	M175×3	17	A+B+15	B-24 L=A+70
S1246L	—	M55×2	30	—	50	-0.025 -0.050	—	—	12	A+B+3	— —
S1552L	—	M60×2	30	—	55	-0.030 -0.060	—	—	12	A+B+1	— —
S1875L	—	M85×2	35	—	80	-0.036 -0.071	—	—	12	A+B	— —
S2091L	—	M100×2	35	—	95	-0.036 -0.071	—	—	12	A+B-10	— —

The dimension L in Fig. 11 is determined from the distance A between the cylinder adapter and the back plate.

Example) In the case of B-206, S1246, the cylinder adapter and back plate distance A = 800,

The total length of the draw pipe is to be $L = A + 41 = 800 + 41 = 841$.

At the time of the screw process of the dimension a, the precision is to be JIS 6H and 6h, 6g matching the screw of the piston of the cylinder. Pay attention so that the thread parts on both ends and the inner periphery do not swing or become unbalanced.

DANGER

- Provide sufficient strength for the draw pipe. If the draw pipe is broken due to insufficiency of the strength, the gripping force will be lost instantly, which is dangerous as the work will fly out.
 - Keep the dimension e and the dimension f in Fig. 11 for the draw pipe and a material with the tensile strength 380MPa (38kgf/mm²) or more must be used.
 - The personnel who designed draw pipe must judge whether the strength of the draw pipe is sufficient for the usage conditions.
 - The dimensions and materials specified in this manual do not guarantee that the draw pipe will not break under every usage condition.
- If the screw-in depth of the draw pipe to the draw nut is insufficient, the screw will break and the gripping force will be lost instantly, which is dangerous as the work will fly out.
- If the draw pipe is unbalanced, vibration occurs, the screw is broken and the gripping force will be lost instantly, which is dangerous as the work will fly out.
- If the engagement of the screw of the draw pipe is loose, vibration may occur resulting in breakage of the screw. If the screw breaks, the gripping force will be lost instantly, which is dangerous as the work will fly out.

9-4 Attachment of cylinder

- When removing/installing the cylinder, use a lifting belt and perform as follows. (Fig.13)
 1. To lift up the cylinder, engage a lifting belt with the draw-pipe and lift up the cylinder while supporting it.
 2. Insert the draw-pipe into the spindle.
 3. When a lifting belt comes close to the spindle, shift the lifting belt toward the cylinder.
 4. When the draw-pipe has entered the spindle sufficiently, re-engage a lifting belt with the cylinder body and fit the cylinder closely to the spindle and then install the cylinder with the cylinder mounting bolts.

Detach in the reverse procedures of attachment.

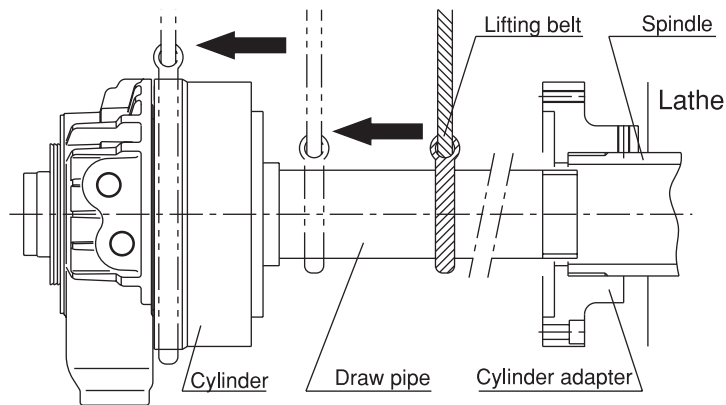

Fig.13

CAUTION

- Use a lifting belt when attaching and detaching the cylinder to and from the machine, as there is a danger of injury or damage if the cylinder drops.
- Use the belt in the center of gravity not to lose the balance, and lift the draw pipe slowly. If balance is bad, the belt slips, and the cylinder drops, and there is the injury danger such as blows.

○ Attach the drain port to be directly underneath. For its structure, if the drain port is not set directly underneath, the hydraulic oil overflows from both ends of the sleeve body resulting in oil leakage.

WARNING

- Doing so may cause oil leakage which could result in a fire. And if the hydraulic oil leaks, the gripping force of the chuck will lower and the work may fly out, which is dangerous.

NOTICE

- To prevent the sleeve body of the cylinder from rotating, provide a support by utilizing the protrusion of the drain port foundation.

- After attaching the support to the lathe, provide clearance between the protrusion of the sleeve body and the support so that force is not applied to the sleeve body.
- As for the run-out when attaching the cylinder, attach the cylinder while keeping the vertical run-out of the sleeve body rear end and the cylinder periphery at the standard value specified in the table 12 or lower when rotation stop of the sleeve body is applied and the spindle is rotated.

Fig. 14

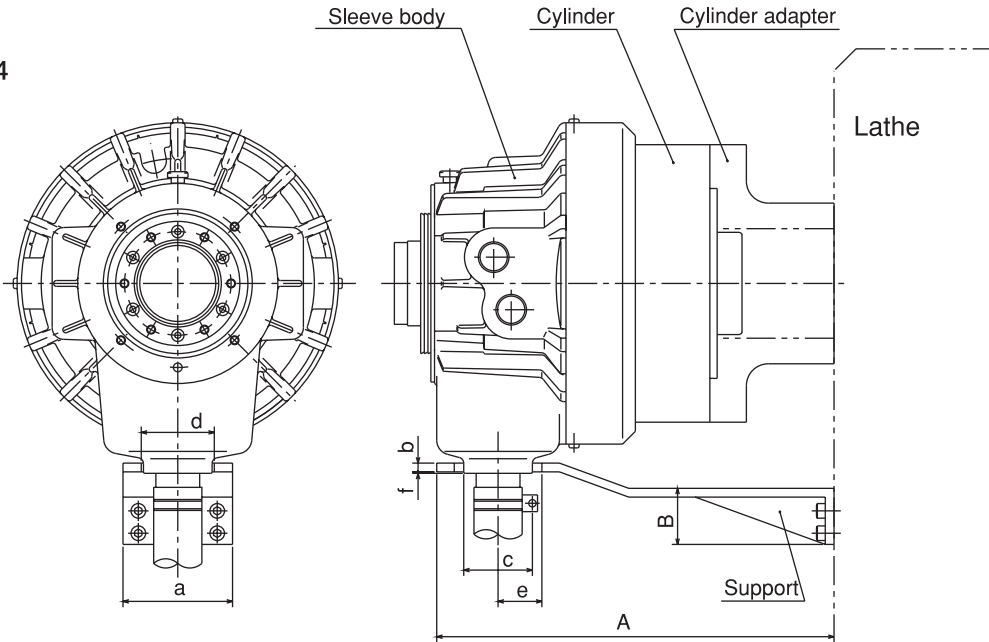

Table 11

(Unit: mm)

Type	A	B	a	b	c	d	e
S1036	Determined by the lathe		75	4.5	φ 47	50	30
S1246, S1246L			75	4.5	φ 47	50	30
S1552, S1552L			75	6	φ 47	50	30
S1875, S1875L			80	6	φ 47	50	30
S2091, S2091L			80	6	φ 47	50	30
S2816			80	6	φ 47	50	30

Fig. 15

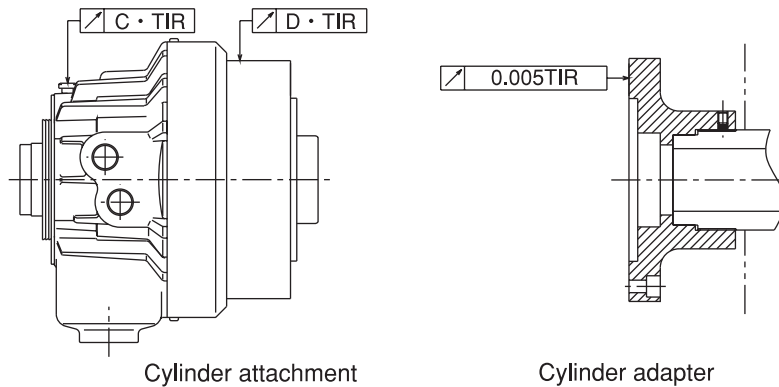

Table 12

(Unit: mm)

Type	C	D	Type	C	D
S1036 or equivalent	0.015	0.010	S1875 or equivalent	0.020	0.010
S1246 or equivalent	0.015	0.010	S2091 or equivalent	0.025	0.010
S1552 or equivalent	0.015	0.010	S2816 or equivalent	0.030	0.010

To obtain the above specified value of run-out, make the surface run-out of the cylinder adapter as small as possible. (0.005 mm TIR or less)

<Attachment of cylinder adapter>

○ In the case of attaching the cylinder first to the cylinder adapter and then to the lathe, place it vertically as shown in the figure below, and attach the tester to the V block made of Duracon and center the cylinder adapter for the periphery reference of the cylinder. (0.010 TIR or less)

To prevent the V block from inclining, provide a reference mark on the plate side to contact the surface.

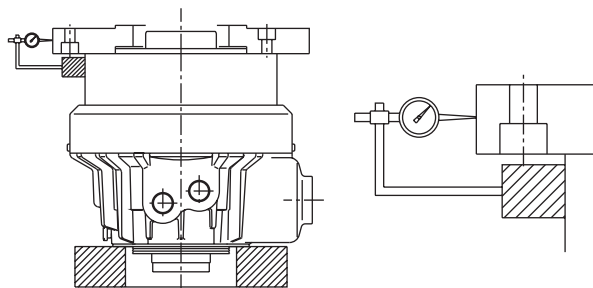

Fig. 16

9-5 Tightening torque of the cylinder attaching bolt

○ In the case of attaching the cylinder to the cylinder adapter, follow the figure below for the screwing depth of the attaching bolt.

Fig. 17

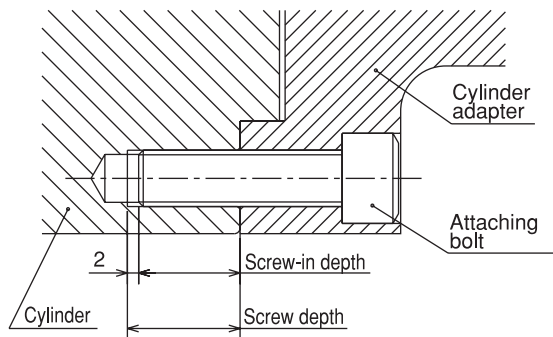

Table 13

Type	S1036	S1246 S1246L	S1552 S1552L	S1875 S1875L	S2091 S2091L	S2816
Boltsize	M10	M10		M12		M16
Screw depth	17	20		24		32

※ Keep the screw-in depth of the bolt to (screw depth -2) mm



- Always tighten the bolts at the specified torque. If the torque is insufficient or excessive, the bolt will break, which is dangerous as the cylinder or work will fly out.
- Use bolts that have at least a strength classification of 12.9 (10.9 for M22 or more) and be sure they are long enough.

Table 14

Bolt size	Tightening torque
M10	58 N·m
M12	85 N·m
M16	200 N·m

※Since the material of the cylinder is aluminum, it is 80% of the tightening torque to the bolt size specified for the hydraulic chuck of our company.

9-6 Attachment of parts other than parts manufactured by Kitagawa Iron Works

Refer to following pages when you attach the other than parts manufactured by Kitagawa Iron Works (a stopper to shorten stroke or spindle work stop, etc.) to the cylinder. (Refer to Fig.18 and Table 15)

Fig. 18

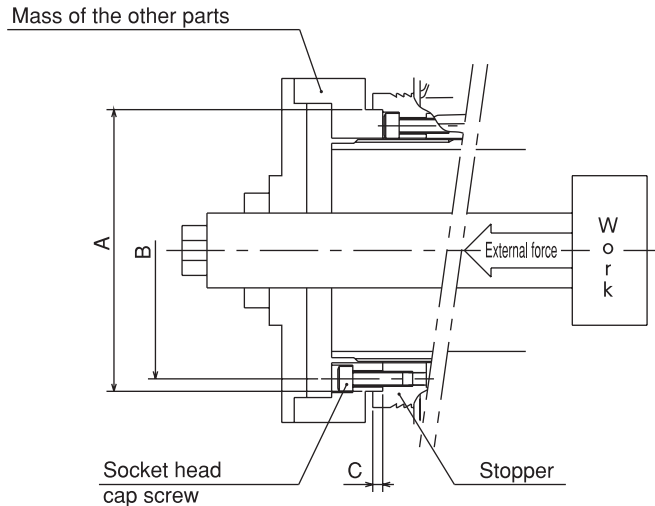

Table 15

Type	ϕ A (H7) (mm)	ϕ B (mm)	C (mm)	Bolt size	Screw depth (mm)	Mass (kg)	External force (kN)	Run-out (mm)
S1036	64	55	4	6-M5	11	2	2.0	0.02
S1246	76	64	4	6-M6	9	2	2.0	0.02
S1552	85	73	4	6-M6	9	3	2.5	0.02
S1875	108	98	4	6-M6	9	3	2.5	0.02
S2091	120	108	4	6-M6	14	3	1.5	0.02
S2816	200	188	4	6-M6	13	3	2.5	0.02
S1246L	76	64	4	6-M6	9	2	2.0	0.02
S1552L	85	73	4	6-M6	9	3	2.5	0.02
S1875L	108	98	4	6-M6	9	3	2.5	0.02
S2091L	120	108	4	6-M6	14	3	1.5	0.02

Note) External force is a value at static load.

⚠ WARNING

- If there is unbalance of the parts to attach, vibrations are generated and cause oil leakage which could result in a fire. and if the hydraulic oil leaks, the gripping force of the chuck will lower and the work may fly out, which is dangerous.
- External force is excessive, the bolt will break, which is dangerous as the cylinder or work will fly out.
- We will not assume responsibility for injury, death, damage, or loss caused by usage of parts not manufactured by Kitagawa Iron Works. Additionally, if parts other than genuine parts manufactured by Kitagawa Iron Works are used, this guarantee will be completely invalid.
- The personnel who designed those parts must judge whether they are safe for the usage conditions.
- The dimensions and value specified in this manual do not guarantee that the cylinder or the parts other than parts manufactured by Kitagawa Iron Works will not break under every usage condition.

10 . About Hydraulic Circuit Design

- Consider the hydraulic circuit design so that the operation is easy and no mistakes in operation occur.
Attempt failsafe for the circuit so as not to cause any accidents even in the case of blackout. (Fig. 19)
- It is incorporated with a lock mechanism to maintain the specified gripping force even if the supplied pressure abnormally drops due to blackout or malfunction of the pressure resource while processing a work, however, it does not function unless the following warnings are observed.

⚠ DANGER

- Use the operation cylinder incorporated with a “lock valve” or “relief valve” to be prepared for blackout.
- Additionally, the solenoid valve is to be in a circuit to retain the gripping port position when no electric current is carried.
The switching of the cylinder is to be 4 port 2 position with electromagnetic valve, and design the hydraulic circuit which grips the work in the state that the solenoid valve is degaussed.
- If the circuit is designed in the opposite way, if there is a blackout, the work could be released and fly out.
- Provide a valve to switch over the inside and outside diameter gripping to prevent an operation mistake when changing the gripping.
Additionally, when a solenoid valve is used as this switching valve, use a 4 port 2 position valve with a position stopper that can retain the indicator circuit at the time of blackout.

Remarks 1) What is a “lock valve” ?

Valve equipped with a function to retain the hydraulic pressure inside the cylinder temporarily when the hydraulic pressure suddenly drops due to blackout, malfunction of the hydraulic pump, etc.

Remarks 2) What is a “relief valve” ?

Valve equipped with a function to prevent breakage when the hydraulic oil filled inside the cylinder caused a pressure increase due to the volume change.

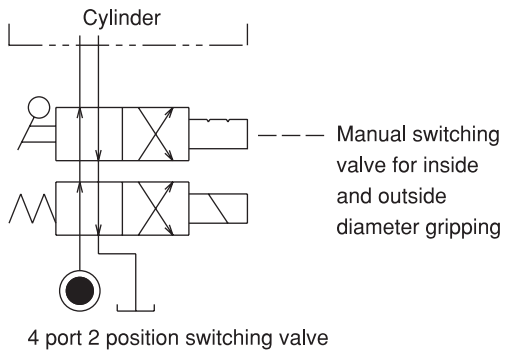

Fig. 19

NOTICE

- Select the operation equipment that matches the pipe diameter of the cylinder. The smaller the diameter is, the larger the pipe resistance becomes and the lower the acting speed is.

<Installation>

The hydraulic pressure supply ports are port A (cylinder pushing side) and port B (cylinder pulling side) in Fig.20. Though both ports A and B have two ports each, connect the pipes to one port respectively and plug the reminders. For the size of each port, see Table 16.

Table 16

Type	S1036	S1246(L)	S1552(L)	S1875(L)	S2091(L)	S2816
A port	Rc3/8			Rc1/2		
B port	Rc3/8			Rc1/2		

11 . Other information

11-1 About standards and orders

This product is based on the following standards or orders.

- Machinery directive : 2006/42/EC Annex I
- EN ISO 12100-1 : 2003+A1 : 2009
- EN ISO12100-2+A1 : 2009
- EN ISO14121-1 : 2007
- EN1550 : 1997+A1 : 2008

11-2 Information about markings of product

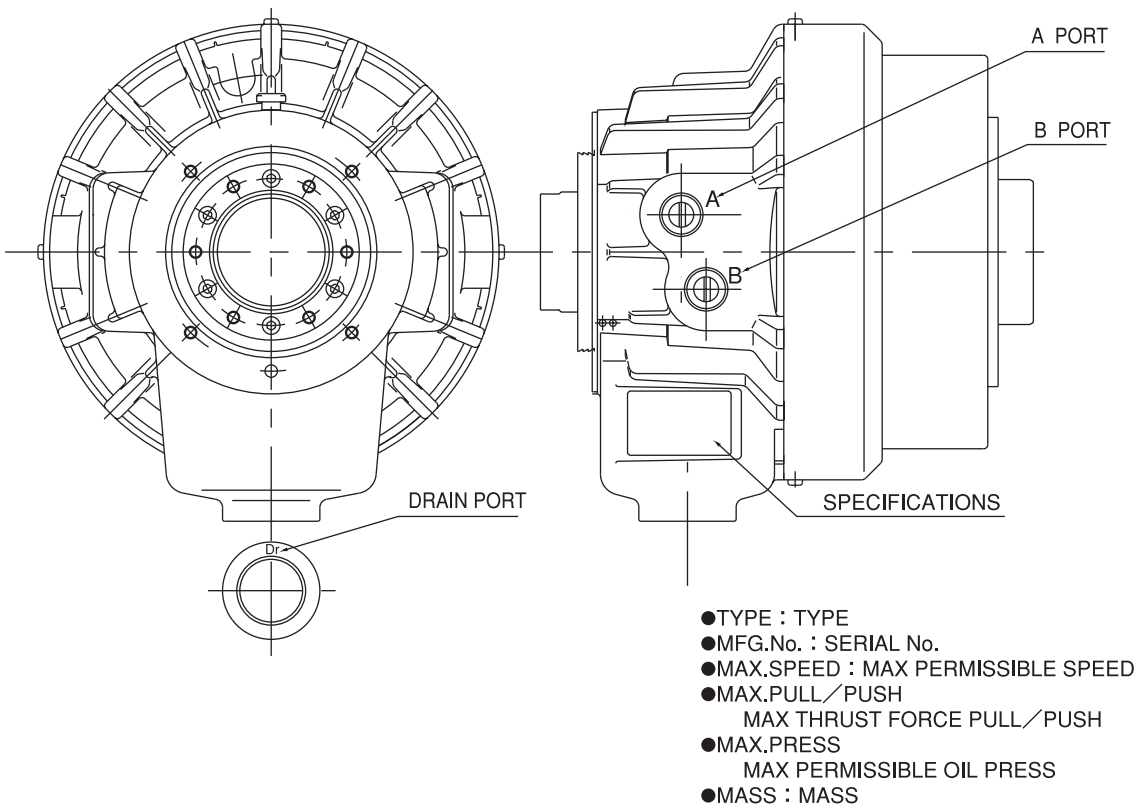

Fig. 20

11-3 About disposal

Ultimate disposal of this product should be handled according to all national laws and regulations.

DECLARATION OF INCORPORATION

We hereby declare that the following our product conform with the essential health and safety requirements of EC Directives so that the product is to be incorporated into end-machinery. The product must not be put into service until end-machinery has been declared in conformity with the provisions of the Directives.

We also declare that undertaking to transmit, in response to a reasoned request by the national authorities, relevant information on the partly completed machinery.

Product : Cylinder

Model : SS Series, S / S-L Series, F Series, M Series,
Y-RE Series, YW-RE Series, SR / SR-C Series

Serial Number : A0000 – Z9999 or 1A0000 – 9Z9999

Manufacturer : KITAGAWA IRON WORKS CO., LTD.
77-1, MOTOMACHI, FUCHU-SHI,
HIROSHIMA 726-8610, JAPAN

Authorised Complier
In The Community : Mark Jones / Financial Director
UNIT 1 THE HEADLANS, DOWNTON,
SALISBURY, WILTSHIRE, SP5 3JJ, UNITED
KINGDOM

Directives : Machinery Directive 2006/42/EC

The above product has been evaluated for conformity with above directives using the following European standards. The technical construction file (TCF) for this product is retained at the above manufacturer's location and it is complied according to ANNEX VII part B.

Machinery Directive:

EN ISO 12100-1:2003+A1: 2009, EN ISO 12100-2:2003+A1: 2009,
EN ISO 14121-1:2007, EN 1550:1997+A1: 2008

Signature : 

Date : 16 October 2014

Name/Title : Mutsuto Kaneshima / Manager Technical Section 1
Technical Department
Machine Tool Accessories Division

Being the responsible person appointed and employed the manufacturer.

KITAGAWA IRON WORKS CO., LTD.

77-1 Motomachi, Fuchu-shi, Hiroshima-pref. 726-8610, Japan Tel. +81 847-40-0526 Fax. +81 847-45-8911

America Contact	KITAGAWA - NORTHTECH INC. http://www.kitagawa.com 301 E. Commerce Dr, Schaumburg, IL. 60173 USA Tel. +1 847-310-8787 Fax. +1 847-310-9484
Europe Contact	KITAGAWA EUROPE LTD. http://www.kitagawaeurope.com Unit 1 The Headlands, Downton, Salisbury, Wiltshire SP5 3JJ, United Kingdom Tel. +44 1725-514000 Fax. +44 1725-514001
	KITAGAWA EUROPE GmbH http://www.kitagawaeurope.de Borsigstrasse 3, 40880, Ratingen Germany Tel. +49 2102-123-78-00 Fax. +49 2102-123-78-69
	KITAGAWA EUROPE GmbH Poland Office http://www.kitagawaeurope.de 44-240 Zory, ul. Niepodleglosci 3 Poland Tel. +48 607-39-8855 Fax. +48 32-749-5918
	KITAGAWA EUROPE GmbH Czech Office http://www.kitagawaeurope.de Lysicka 3, 621 00 Brno, Czech Republic Tel. +420 603-856-122 Fax. +420 549-273-246
Asia Contact	KITAGAWA INDIA PVT LTD. Lotus House East, Lane 'E' North Main Road, Koregaon Park, Pune, 411 001, Maharashtra, India Tel. +91 20-6500-5981 Fax. +91 20-2615-0588
	KITAGAWA (THAILAND) CO.,LTD. Bangkok Office 9th FL, Home Place Office Building, 283/43 Sukhumvit 55Rd. (Thonglor 13),Klongton-Nua, Wattana, Bangkok 10110, Thailand Tel. +66 2-712-7479 Fax. +66 2-712-7481
	KITAGAWA IRON WORKS CO.,LTD. Singapore Branch #02-01 One Fullerton, 1 Fullerton Road, Singapore 049213 Tel. +65 6838-4318 Fax. +65 6408-3935
	KITAGAWA IRON WORKS (SHANGHAI) CO.,LTD. Room308 3F Building B, Far East International Plaza,No.317 Xian Xia Road, Chang Ning, Shanghai, 200051China Tel. +86 21-6295-5772 Fax. +86 21-6295-5792
	DEAMARK LIMITED http://www.deamark.com.tw No. 6, Lane 5, Lin Sen North Road, Taipei, Taiwan Tel. +886 2-2393-1221 Fax. +886 2-2395-1231
	KITAGAWA KOREA AGENT CO.,LTD. http://www.kitagawa.co.kr 803 Ho, B-Dong, Woolim Lion's Valley, 371-28 Gasan-Dong, Gumcheon-Gu, Seoul, Korea Tel. +82 2-2026-2222 Fax. +82 2-2026-2113
Oceania Contact	DIMAC TOOLING PTY.LTD. http://www.dimac.com.au 61-65 Geddes Street, Mulgrave, Victoria, 3170 Australia Tel. +61 3-9561-6155 Fax. +61 3-9561-6705

The products herein are controlled under Japanese Foreign Exchange and Foreign Trade Control Act. In the event of importing and/or exporting the products, you are obliged to consult KITAGAWA as well as your government for the related regulation prior to any transaction.