

# NC Tilting Rotary Table INSTRUCTION MANUAL Model: TT182BER01



## **DANGER**

- This instruction manual is for production engineers and maintenance personnel in charge of operation of this product. When a beginner uses this product, receive instructions from experienced personnel, the distributor or our company.
- Before installing, operating or maintaining this equipment, carefully read this manual and the safety labels attached to the equipment. Failure to follow these instructions and safety precautions could result in serious injury, death, or property damage.
- Store this manual near equipment for future reference.
- If any questions related to safety arise about this manual, please confirm them with the distributor or our company.

KITAGAWA IRON WORKS CO., LTD.



Thank you for choosing the Kitagawa NC Rotary Table.

Kitagawa, a world-renowned precision equipment manufacturer, has developed the finest quality NC Rotary Table with emphasis in high precision and rigidity as its basic principals in design.

This unit is installed on the machining centers and suitable for indexing the angle of machining position of the workpieces. Please contact us if it is used for any other applications.

This NC Rotary Table has been designed to provide years of high precision performance. To ensure optimum and trouble-free performance, please read this operation manual carefully before using the unit and retain this copy for your future reference.

Please pay close attention to the procedures with the following warning marks  to avoid severe injury and/or accident.

## **Safety Alert Symbol**

This is the industry “ Safety Alert Symbol ”. This symbol is used to call your attention to items or operations that could be dangerous to you or other persons using this equipment.

Please read these messages and follow these instructions carefully. It is essential that you read the instructions and safety regulations before you attempt to assemble or use this unit.



**Indicates an Imminently hazardous situation which, if not avoided, will result in death or serious injury.**



**Indicates a potentially hazardous situation which, if not avoided, could result in death or serious injury.**



**Indicates a potentially hazardous situation which, if not avoided, may result in minor or moderate injury.**



**Instructions for table performance and avoiding errors or mistakes.**

## EC DECLARATION OF CONFORMITY

We hereby declare that the following our product conforms with the essential health and safety requirements of EC Directives.

Product : NC ROTARY TABLE

Type : MR Series, GT Series, MX Series, TMX Series  
THX Series, TRX Series, TLX Series, TBX Series  
TUX Series, TR Series, TL Series, LR Series  
TM Series, TH Series, TT Series, TW Series  
DM Series

Directives : Machinery Directive 2006/42/EC  
EMC Directive 2004/108/EC

The above product has been evaluated for conformity with above directives using the following European standards.

Machinery Directive:

EN ISO 12100-1:2003+A1:2009, EN ISO 12100-2:2003+A1:2009,  
EN ISO 14121-1:2007, EN 60204-1: 2006+A1:2009, others

EMC Directive:

Emission : EN 55011+A2:2007  
Immunity : EN 61000-6-2:2005

---

## CONTENTS

---

	Page
1. For Your Safety .....	1
2. Outside view .....	8
3. Specifications .....	9
4. Accuracy Standard .....	11
5. Operation Ready .....	12
5-1. Table transfer and mounting to machine tool	
5-2. Oiling	
5-3. Required lubrication oil volume	
5-4. Required operation oil volume (For air hydro booster at pneumatic/hydraulic spec.)	
5-5. Recommended lubrication oil	
5-6. Recommended operation oil (For air hydro booster at pneumatic/hydraulic spec.)	
5-7. Safety of Oil and Antirust Oil Used for the Unit	
6. Inspection .....	17
7. Use of NC Rotary Table .....	17
8. Table Clamp .....	18
8-1. Precautions for table clamp	
8-2. Supply of pneumatic and hydraulic pressure for clamp	
8-3. Air Relief	
8-4. Air purge	
8-5. Checking device for Clamp/Unclamp	
8-6. Solenoid valve for Clamp/Unclamp	
9. Mounting of Workpiece .....	30
10. Maintenance Work .....	31
10-1. Corrective Action in Case of Failure, and Disassembly	
10-2. Before Performing Maintenance Work	
11. Backlash Adjustment of Worm Gears .....	32
11-1. Backlash measuring method of worm gear of rotating axis	
11-2. Backlash measuring method of worm gear of tilting axis	
11-3. Backlash adjusting method of rotating axis worm gear	
11-4. Backlash adjusting method of tilting axis worm gear	
12. Backlash Adjustment of Spur Gears .....	37
12-1. Backlash adjusting method of rotating axis drive spur gears	
12-2. Backlash adjusting method of tilting axis drive spur gears (TT182)	
12-3. Backlash adjusting method of tilting axis drive spur gears (TW182)	
13. ZRN (Zero Return) Device .....	41
13-1. Rotating axis ZRN device	
13-2. Tilting axis ZRN device	
14. Tilting Axis Over Travel Stop Device .....	43
14-1. Tilting axis over travel stop device	
14-2. Adjusting methods of dog for vertical over-travel	
14-3. Adjusting methods of dog for horizontal over-travel	
15. Motor Case .....	46
15-1. To remove motor case	
15-2. Countermeasures for waterproof	

	Page
16. Motor .....	48
16-1. Tilting axis drive motor	
16-2. Rotating axis drive motor	
16-3. To mount spur gears	
17. Connector .....	52
17-1. To remove connector	
17-2. To mount connector	
18. Troubleshooting .....	54
19. Parts List .....	57
20. Storage .....	64
21. Disposal of NC Rotary Table .....	64
22. Reference Data .....	65
22-1. Conversion of arc length and angle	
22-2. Coordinate calculation of table center for tilting angle	
22-3. Workpiece interference area	
23. Piping Diagram on Air Hydraulic System .....	67
23-1. Outside view of connection piping system	
23-2. Pneumatic/hydraulic circuit diagram	
24. Piping Diagram on Hydraulic System .....	72
24-1. Outside view of connecting piping system	
24-2. Hydraulic circuit diagram	
25. Outside view of Air Hydraulic Part .....	74
 Appendixes	
Appendix 1 Outside View	
Appendix 2 Wiring Diagram	
Appendix 3 Details of Nameplate	

# 1. For Your Safety

## Basic Safety Tips

Please read this manual and follow instructions carefully.

We cannot assume responsibility for damage or accidents caused by misuse of the NC Rotary indexing tables, through non-compliance with the safety instructions.



Turn off the main power of the machine prior to maintenance, check, or repair of the unit, Failure to do so may cause severe injury and/or accident.

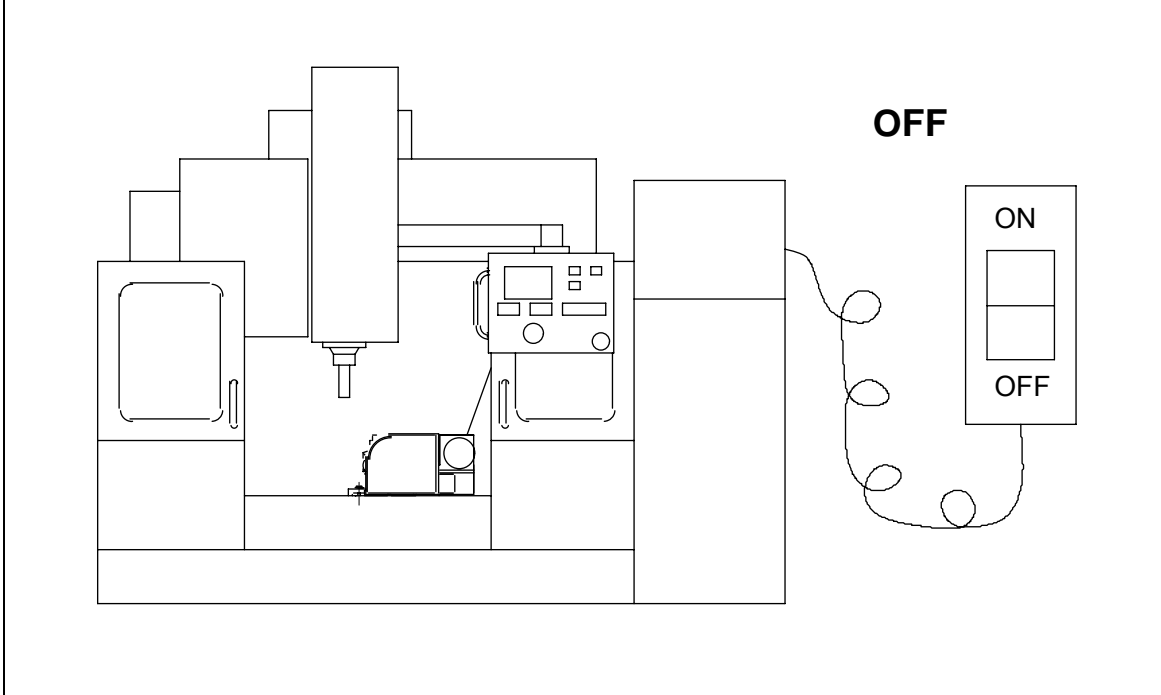



**WARNING**



Tighten the bolts securely when mounting the unit on the machine table.

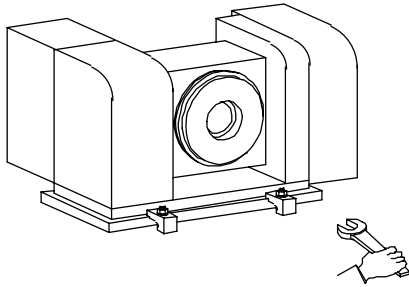

Please refer to the chart below for the recommended tightening torque of the bolts.

Hex. Bolt Size	Torque N·m
M10	33.8
M12	58.9
M16	146.3
M20	294.3



Do not touch rotating object during operation.

Fingers or hand may be caught into gap.

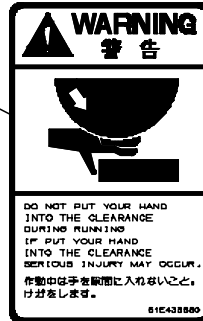
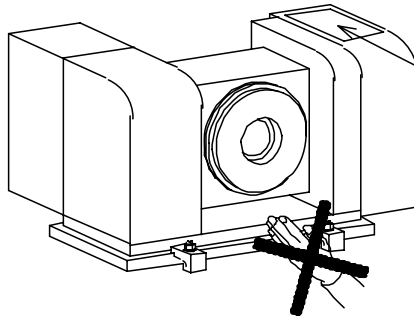

Make sure the working area is clear of any foreign object and/or hand when the unit is in operation to avoid any serious accident and/or injury.

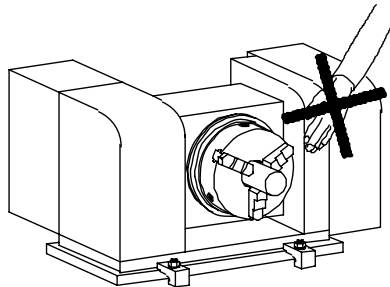





Please consult your local distributor before attempting any modification of the unit.

The NC rotary table may malfunction.

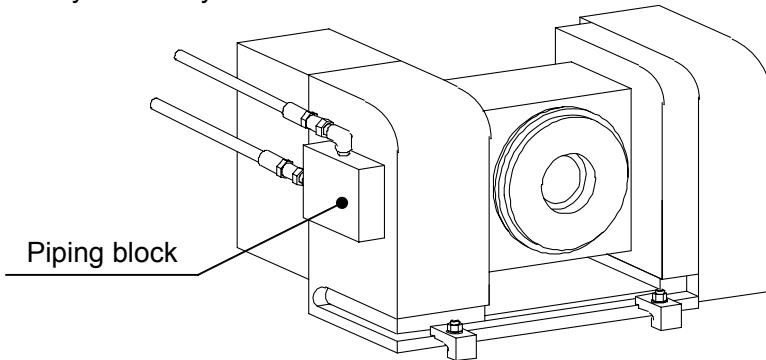

Do not apply cutting force which exceeds the specification in this manual. Failure to do so may cause severe injury and/or damage to the unit.

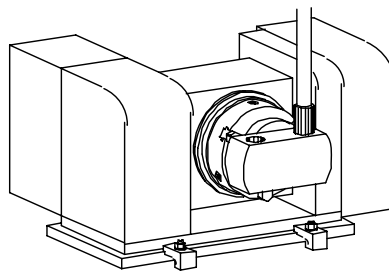

Please consult your local distributor before attempting any modification of the unit.

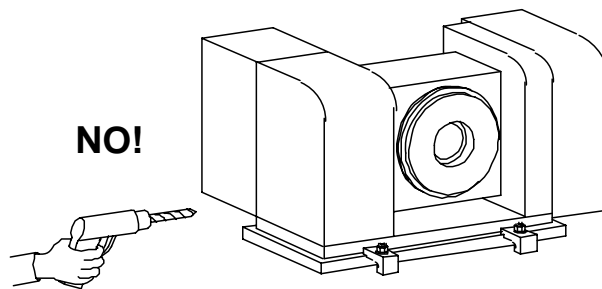



Maintain adequate clearance between the unit and any part of the machine.

Avoid bending the external cables and air tube of the unit.

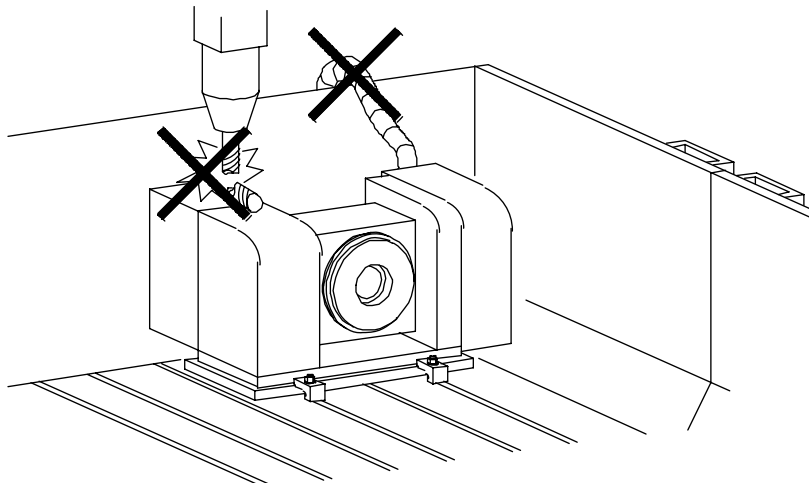

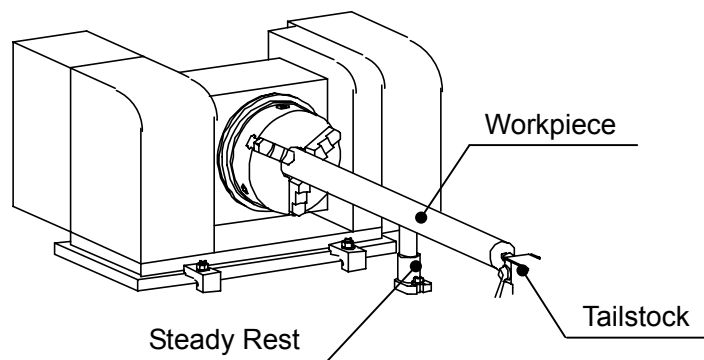

Use a support, steady rest, or tailstock for heavy or long workpieces to prevent any injury and/or accident.





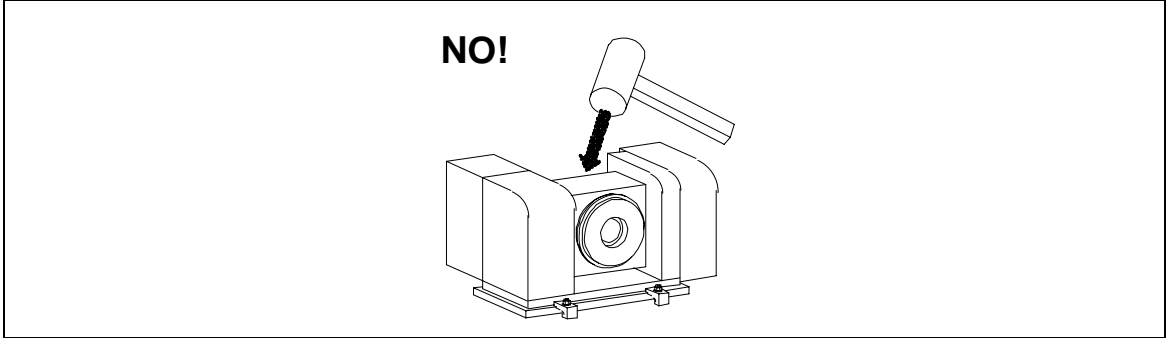

 Avoid sudden impact to any part of the unit which may cause damage to the internal mechanism.

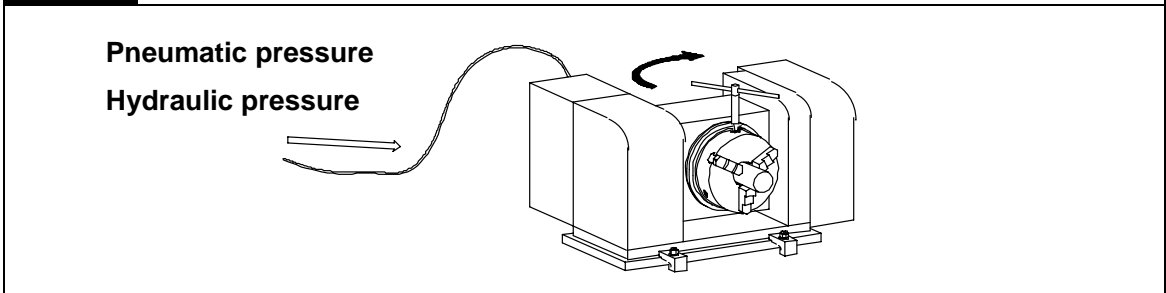

 Mount or dismount the workpiece to or from the unit while the unit is clamped to avoid damage to the internal mechanism and diminished indexing accuracy of the unit.



 When transporting the unit, make sure to use eye bolts and a sufficient leash or wire.

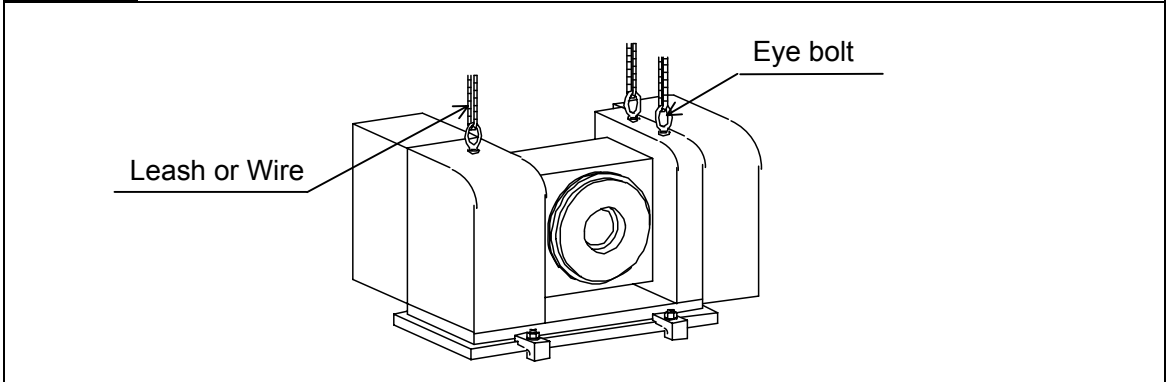

**CAUTION**



Supply air through Air combination (Air filter, Mist separator, regulator) + Drain catcher. (The air supply port is on the motor case.)

Apply air purge inside the motor case and be sure to provide dry air.

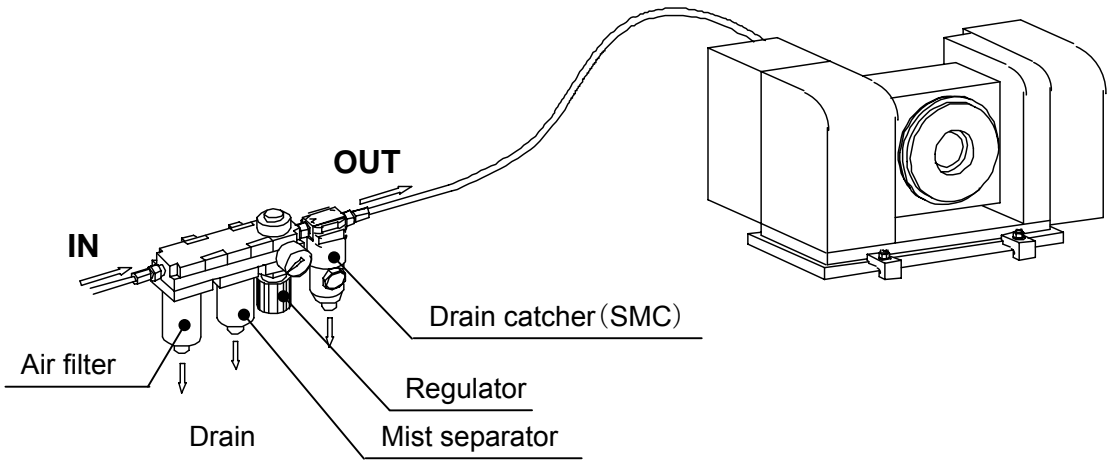

Periodically drain the water in air filter. (It is recommended to use the auto drain type.)

**NOTICE**



Replace lubricating oil every 6 months.

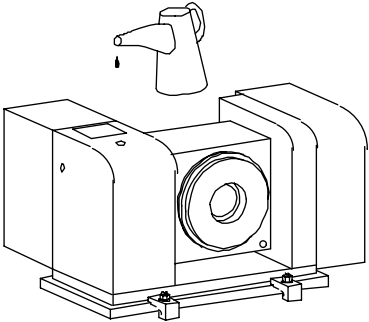

# NOTICE



Coat each cover mounting face for motor case with liquid packing.

Because coolant is entered,  
NC rotary table may be damaged.

注意  
接続工事等の後、カバーを組み付けるときは必ずシリコン系液状ガスケットをむらなく塗布してください。  
ATTENTION  
After covers are removed, to assure water-tightness, a liquid silicon gasket must be applied before replacing covers.

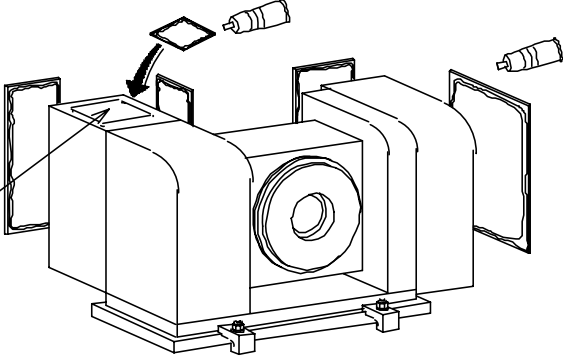

Attach each O-ring to motor case mounting face, etc. as shown in the following figure. (No damages on O-rings)

Because coolant is entered,  
NC rotary table may be damaged.

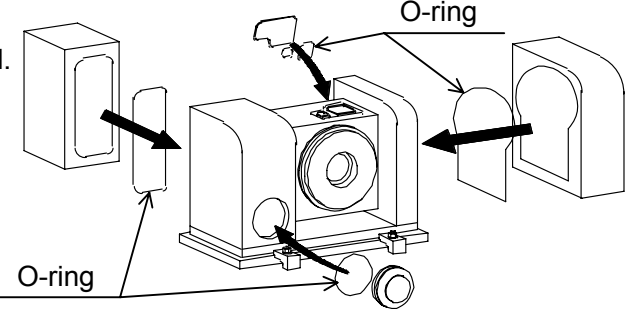

## 2. Outside view

The following figure is the standard outline drawing of model TT182. Since the table clamp device is displayed without classifying the oil hydraulic pressure specification and the pneumatic specification in the following figure, the oil hydraulic pressure supply port becomes valid only when the oil hydraulic pressure system is used.

Thus, the air hydraulic booster is built-in only when the air hydraulic pressure system is used. For detailed models, refer to attached outside view.

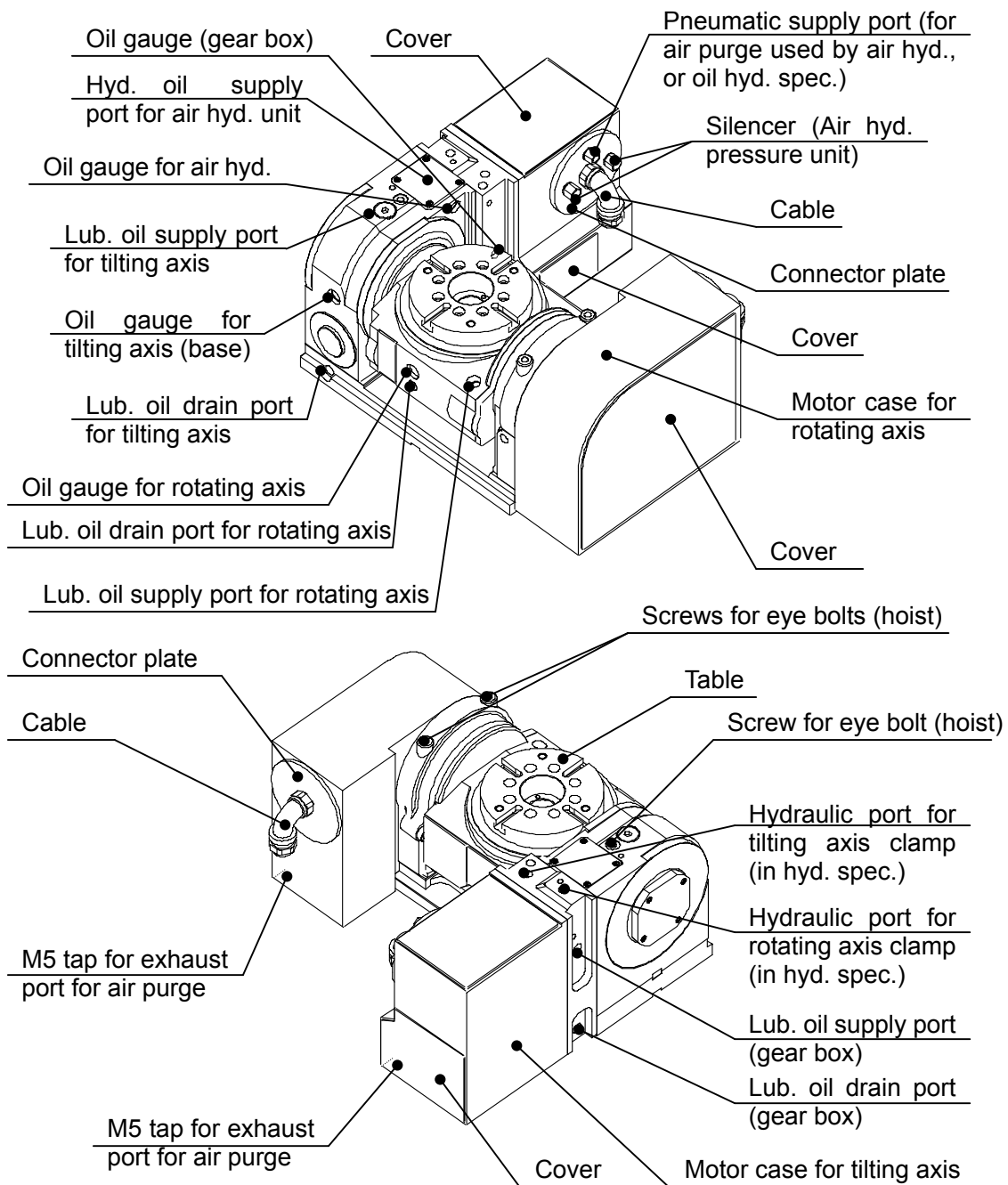

### 3. Specifications

	ITEM	MODEL		TT182	TW182
1	Table Diameter	mm		φ 180	φ 180
2	Table Height in Horizontal	mm		250	250
3	Center Height in Vertical	mm		180	180
4	Total Height in Vertical	mm		304	304
5	Table reference hole diameter	mm		φ 65	φ 65
6	Table through hole diameter	mm		φ 40	φ 40
7	Clamping Torque [Pneumatics 0.5MPa]	(Rotating axis)	N·m	450	450
		(Tilting axis)	N·m	800	800
	Clamping Torque [Hydraulic 3.5MPa]	(Rotating axis)	N·m	450	450
		(Tilting axis)	N·m	800	800
8	Allowable Workpiece Dia.	mm		φ 180	φ 180
9	Allowable Mass of Workpiece	(Horizontal)	kg	60	60
		(Vertical)	kg	40	40
10	Allowable Work Inertia	kg·m <sup>2</sup>		0.25	0.25
11	Total Reduction Ratio	(Rotating axis)		1/90	1/90
		(Tilting axis)		1/180	1/180
12	Max. Rotation Speed	(Rotating axis)	min <sup>-1</sup>	33.3	33.3
		(Tilting axis)	min <sup>-1</sup>	16.6	16.6
13	Angle of tilting	degree		-35~110	-35~110
14	Mass of Rotary Table	kg		About 155	About 170
15	Operating temperature range	°C		5~40	
16	Operating humidity range	%		30~95	
17	Operating altitude range (above sea level)	m		1000 or lower	
18	Storage temperature range	°C		-10~60	
19	Environmental pollution degree			Degree 3	
20	Noise level	dB		79	

※The noise level is measured at a distance of 1m from the NC rotary table in front, rear, left, and right four positions of the unit.

※When storing the unit, conduct the antirust treatment and store it in a place free from wetting, condensation, or freeze.

## NOTICE

The above specification table shows the values at standard specifications. For details, refer to the Outside View.

## NOTICE

Max. table rotation speed is the value when the motor rotates at 3000 min<sup>-1</sup>.



## CAUTION

Be sure to observe the allowance work inertia even if the mass of workpiece is within the allowable value.



## CAUTION

There is any case that the tailstock is required by the mass of workpiece, shape, cutting conditions, etc.



## CAUTION

For the conditions for using the table, refer to the above specification columns and caution items. Set each cutting condition so as not to exceed the allowance value.



## 4. Accuracy Standard

(Unit: mm)

Inspection Item		Allowable Value		
1	Run out of table reference hole	0.010		
2	Run out of table top face during table rotation	0.015		
3	Straightness of table top face (to be concave side.)	Total length	0.010	
4	Parallelism of table top face and mounting reference face (tilting axis direction)	Total length	0.020	
5	Parallelism of table top face and guide block center line (Tilting angle : 90°)	Total length	0.020	
6	Parallelism of tilting axis center line and mounting reference face	Total length	0.020	
7	Indexing accuracy	Rotating axis	Cumulative	20 sec
		Tilting axis	Cumulative	60 sec
8	Repeatability	Cumulative	4 sec	

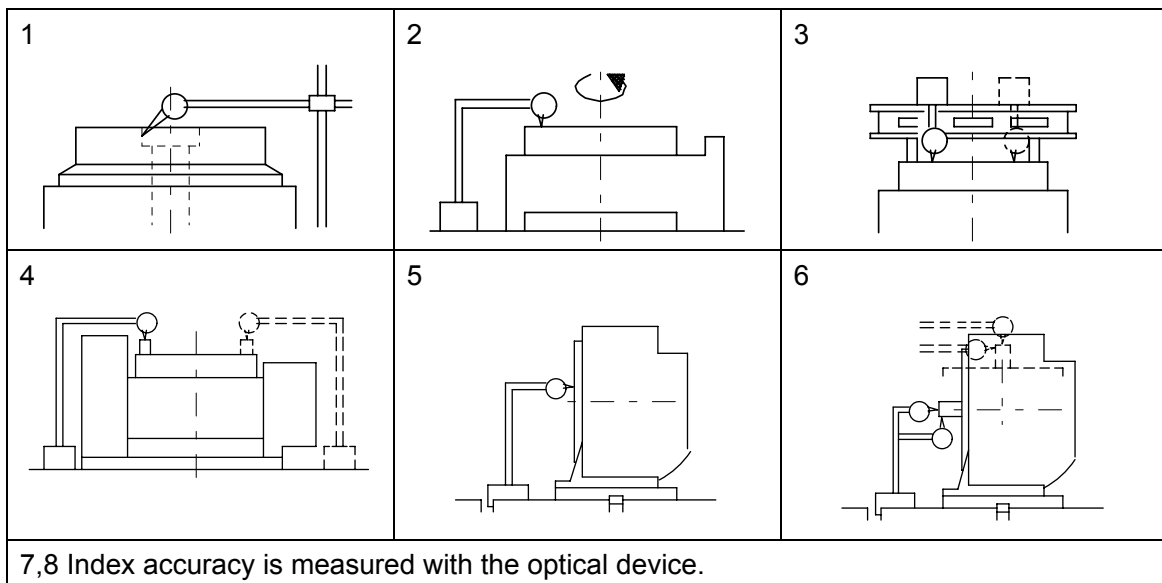

## 5. Operation Ready

After unpacking, the tilting rotary table is mounted to the machine tool. Observe the following procedure before performing the operation (trial run).

### 5-1. Table transfer and mounting to machine tool

- 1) When transporting the unit, hook ropes to the eyebolts attached and transport the unit carefully, not giving a shock. The ropes used should be wire ropes having enough strength to lift up the unit.
- 2) Clean the table face on the machine tool and the mounting base surface of NC table after checking that burr or flaw is not found. If the burr or flaw is found, repair them with the oil grinding stone.
- 3) The motor case may be removed depending on the maintenance work. Accordingly, whenever possible, install the NC rotary table in a position where the motor case can be removed. In case of vertical installation, the guide blocks will fit into the slotted groove on the machine. If there is any play between the guide block and the T-slot, place the unit against one side of the T-slot to eliminate the gap.
- 4) Securely fix the NC rotary table to the machine tool with the attached clamper.



Do not enter a part of your body under the NC rotary table during transportation.

Unexpected accidents such as a disengagement of lifting devices may cause the NC rotary table to drop on your body.



When mounting the NC rotary table to the machine tool, check the mounting space carefully. Especially, take care so that the NC rotary table, cables and air/hydraulic hoses will not interfere with the splash guard or ATC device and spindle head of machine tool because the table or spindle head moves.



Do not damage the cables by placing a heavy thing or pinching them. If the cables are damaged, there is a danger of electric shock.



Tighten the bolts of clamper at the specified torque by using the mounting seat effectively.



The transport and lifting devices must be operated only by the qualified persons for respective devices.

Operating the transport devices by an unqualified person causes the NC rotary table or machine to be damaged due to an operation error, resulting in accidents.



When transporting a pallet on which NC rotary table is mounted, take measures against over-turning or drop.

Transporting the pallet with NC rotary table mounted unstably may cause the NC rotary table to overturn and then to drop from the pallet.



Disconnect electric cables and working fluid piping when relocating the NC rotary table.

Relocating the NC rotary table with electric cables and working fluid piping connected and hung down causes the NC rotary table to be unstable or the worker to be tripped, resulting in unexpected accidents.

Electric cables or working fluid piping may be damaged during relocation, and if the NC rotary table is installed on the machine again, unexpected accidents may occur.

If electric cables and working fluid piping cannot be disconnected, secure them to the NC rotary table.

## 5-2. Oiling

Lubrication oil has been already filled in NC rotary table before shipping. Check that the lubrication oil is filled to the center position of the oil gauge before operating the machine.



Replace lubrication oil every 6-month. At this time, completely drain the oil. When filling the oil tank with lubrication/hydraulic oil, remove the chip and foreign matter on the oil filler neck. If the chip and foreign matter are entered, the important parts such as the worm gear, bearings, etc., are seized and accuracy is reduced. In the air/hydraulic specification, a clamp alarm occurs.



In the worm part, fill the tank with lubricating oil to center position of oil gauge. Fill the tank of air hydraulic part with the lubrication oil to the highest level of oil gauge. The shortage of oil leads to the insufficient performance of table. Use the lubricating oil recommended in the table on the item 5-5. Use the hydraulic oil recommended in the table on the item 5-6.

### 5-3. Required lubrication oil volume

(Unit: liter)

Type	TT182	TW182
Tilting axis	0.45	0.45
Gear box	0.2	0.65
Rotating axis	0.6	0.6

Filled with Daphne Multiway 32MT (IDEMITSU) before shipping.

### 5-4. Required operation oil volume

(For air hydro booster at pneumatic/hydraulic spec.)

An oil gauge level position varies depending on a serial No.

(Unit: liter)

Model	TT182		TW182	
	Serial No.	~070167	070167~	~*****
Operation oil	0.3	0.3	0.5	0.5
The level of oil gauge	Top	Details of oil gauge	Top	Details of oil gauge

Filled with Daphne Neo fluid 32 (IDEMITSU) before shipping.

To check the serial No., see the nameplate on the machine.

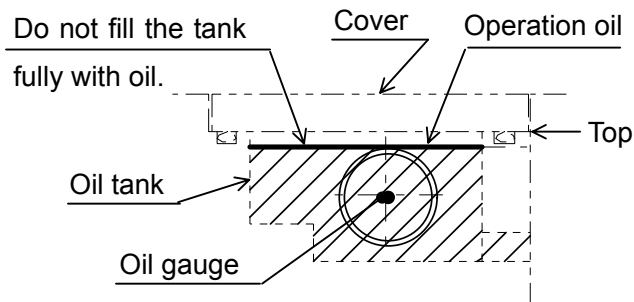

**The level of oil gauge**

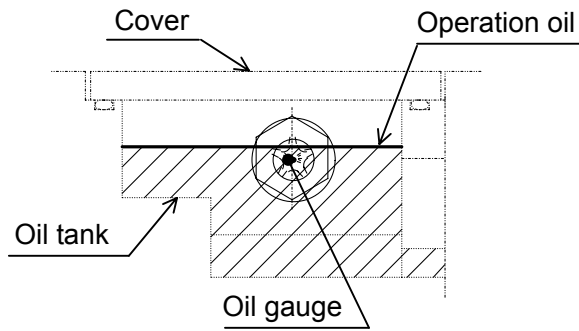

**The level of oil gauge**

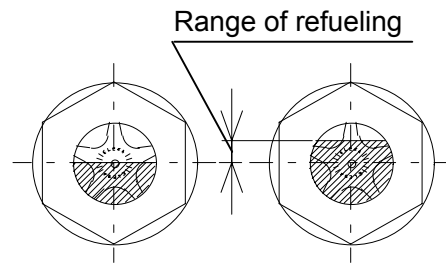

**Details of oil gauge**

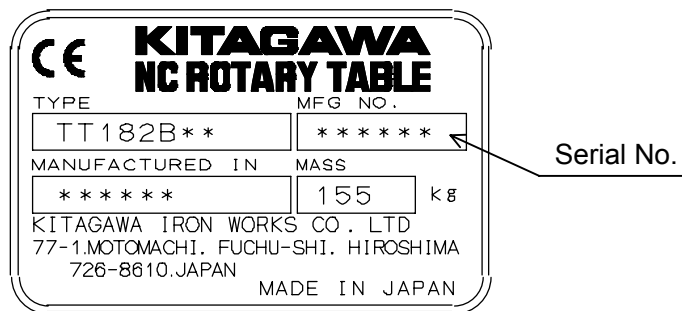

**Name Plate**

**5-5. Recommended lubrication oil**

(Viscosity grade ISO VG32)

Maker	Name
IDEMITSU	Daphne Multiway 32MT
MOBIL	Vactra oil No. 1
JOMO	Slidus HS32
SHELL	Shell Tonna oil S32
NIPPON OIL	Uniway EV32
COSMO	Dynaway 32

**5-6. Recommended operation oil**

**(For air hydro booster at pneumatic/hydraulic spec.)**

(Viscosity grade ISO VG32)

Maker	Name
IDEMITSU	Daphne Neo Fluid 32
	Daphne Super Hydro 32A
MOBIL	Mobil DTE XL32
COSMO	Cosmo Super Epoch ES32
NIPPON OIL	Super Hyrando SE32
SHELL	Shell Tellus Oil 32

## **5-7. Safety of Oil and Antirust Oil Used for the Unit**

### **5-7-1. Scope of application**

- Specified lubricating oil
- Specified hydraulic oil (MR, MX, GT, TM2100·3100, TH2100·3100, TT(S)101·120, TT140, DM do not use)
- Antirust oil applied to the unit at delivery (Houghton Japan, Rust Veto 377)

### **5-7-2. First-aid treatment**

Aspiration: In case of much aspiration, go to a place where there is fresh air, and cover your body with a blanket to keep your body warm. Consult a doctor if necessary.

Sticking to your skin: Wipe off the oil, and wash your skin with water and soap. If you feel itchy or you get inflamed, consult a doctor immediately.

Entering your eye: Wash your eye with fresh water for at least 15 minutes, and then consult a doctor.

Accidental drinking: Consult a doctor immediately without vomiting forcibly. If you are polluted in your mouth, wash with water thoroughly.

- For lubrication oils and hydraulic oils other than specified ones, and antirust oils prepared by the customer, refer to the safety information prepared for respective oils.

### **5-7-3. Flammable characteristics**

- Watch out for fire since lubricating oil and hydraulic oil are flammable. Hazardous substances will be generated if they combusted.
- The flash point of lubricating oil and hydraulic oil put in the unit at the delivery exceeds 200°C. It may be different from that of the lubricating oil and hydraulic oil prepared by the customer.
- Antirust oil is highly volatile and thus likely to catch fire, and also it mixes with air to form explosive mixture gas.
- The flash point of antirust oil applied to the unit at the delivery is 38°C. It may be different from that of the antirust oil prepared by the customer.

### **5-7-4. Disposal of lubricating oil and hydraulic oil**

Dispose of used lubricating oil and hydraulic oil exhausted from this unit in accordance with the laws and regulations of your country. You may suffer punishment if you disposed of waste oil without following the laws and regulations.

## **6. Inspection**

### Daily inspection

- 1) Check the fixing condition of NC rotary table (including jig if mounted).
- 2) Confirm that the chips accumulating in a rotary part of NC rotary table are removed.
- 3) Check the electric connection cables and the air hoses are not damaged, and also, check the pneumatic and hydraulic pressure.
- 4) Check the oil volume of air hydraulic system. (Check that the oil level of hydraulic oil is in the upper part of oil gauge.)
- 5) Check the zero return motion (machine), indexing motion and position.
- 6) Check unusual vibration and noise do not occur. (Body, motor)
- 7) Check unusual heating. (Body, gear box, motor)

### Periodical inspection (Inspect the following items every 6-month.)

- 1) Check the dirt degree of lubrication oil.
- 2) Check the dirt degree of hydraulic oil.
- 3) Check connectors are well mounted and cables are not damaged.
- 4) Check wiring cables in the motor case do not corrode or are disconnected.

## **7. Use of NC Rotary Table**

This unit is installed on the machining centers, and on its table surface the chuck or fixture is attached to clamp the workpiece. It indexes the angle of machining position by the control of machining center or Kitagawa's own controller. During the machining, the working fluid is supplied to retain the workpiece.

## 8. Table Clamp

### 8-1. Precautions for table clamp



Be sure to rotate the table with the table unclamped and use the table with it clamped when machining after positioning. If the table is operated by mistake, take care since the worm wheel may be damaged. Check the signals of pressure switch to check Clamp/Unclamp operations.



Never operate the table at clamping torque or more in specification column because the clamping part will be worn and the worm wheel also will be damaged.



Clamped status is not canceled completely when residual pressure remains while unclamping. Thus, the table operation may continue under half clamped condition. Since the above mentioned case leads to the seizing of worm gear and clamped part, take extreme care of back pressure. In case of especially hydraulic clamp, design the circuit so that back pressure is less than 0.2 MPa while unclamping.



If a silencer is clogged with cutting fluid etc., there are possibilities that compressed air may not be exhaust and it leads unclamp failure alarms. To avoid clogging, maintain silencer periodically.

### 8-2. Supply of pneumatic and hydraulic pressure for clamp

The clamber to clamp the table is incorporated in the NC rotary table and two air and hydraulic clamp specifications are provided for operation. However, in the air pressure clamp specifications, the air hydraulic booster is incorporated in the table. Since the NC rotary table is delivered in accordance with the customer's specifications, supply a pressure source according the specifications.

#### 8-2-1. Pneumatic clamp specifications

- 1) Supply clean air (moisture, oil content, powder dust eliminated) passing through the air combination (Air filter, mist separator, regulator) + drain catcher.



- 2) Connect the pipe exclusive for air pressure durable to max. operating pressure over 0.6 MPa to the air pressure supply port. The air pressure supply port is provided on the motor case. See the external view attached for details. (Connection port is Rc1/4).
- 3) Use this unit in the air pressure range of 0.5 to 0.6 MPa.
- 4) If the air remains in the table clamp device, the specified clamp torque cannot be attained. Thus, perform the air bleeding work as follows:
  1. See the external view attached to check the location of air bleeding plug.
  2. Cover the air bleeding plug with a waste cloth and insert a hexagonal wrench key, and with the wrench held by hand, loosen slowly the plug by about 3 turns.
  3. With the wrench held by hand, repeat the clamp and unclamp operations to bleed residual air.
- ※ Loosening the air bleeding plug excessively could cause the plug or steel ball to fly out.
- 5) After the air bleeding work finished, tighten the air bleeding plug, and repeat the clamp and unclamp operations to check that hydraulic oil does not leak.

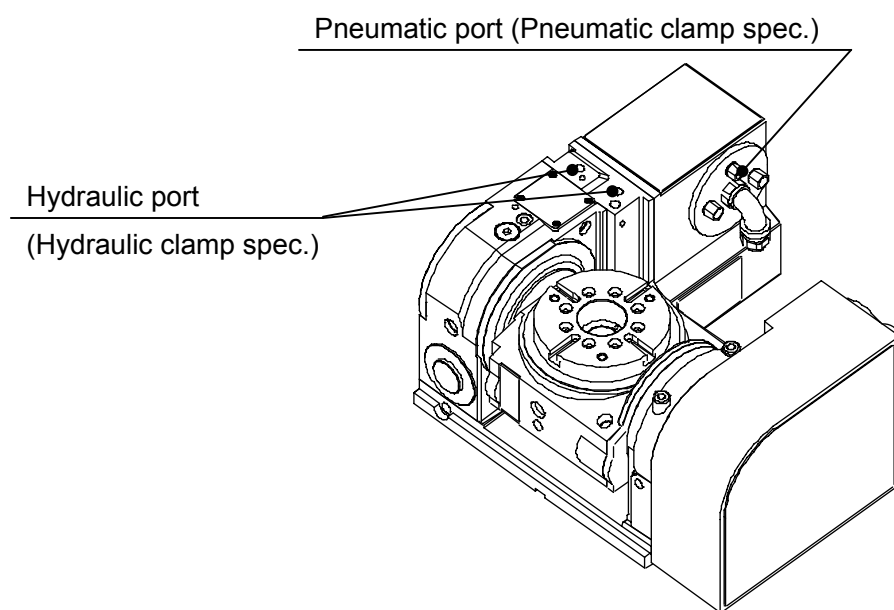

**Fig.1-1 (TT182)**

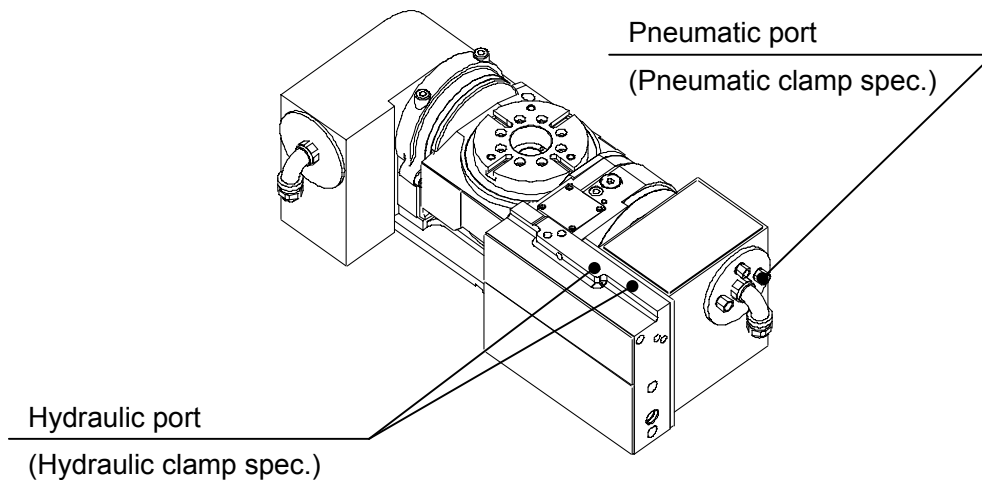

**Fig.1-2 (TW182)**

### 8-2-2. Hydraulic clamp specifications

- 1) Connect the pipe exclusive for hydraulic pressure durable to max. Operating pressure over 3.7 MPa to the hydraulic pressure supply port. (Connection port is Rc3/8)
- 2) Use this unit in the hydraulic pressure range of 3.5 to 3.7 MPa.
- 3) If the air remains in the table clamp device, the specified clamp torque cannot be attained. Thus, perform the air bleeding work as follows:
  1. See the external view attached to check the location of air bleeding plug.
  2. Cover the air bleeding plug with a waste cloth and insert a hexagonal wrench key, and with the wrench held by hand, loosen slowly the plug by about 3 turns.
  3. With the wrench held by hand, repeat the clamp and unclamp operations to bleed residual air.
- ※ Loosening the air bleeding plug excessively could cause the plug or steel ball to fly out.
- 4) After the air bleeding work finished, tighten the air bleeding plug, and repeat the clamp and unclamp operations to check that hydraulic oil does not leak.



Port Rc 1/4 is provided. In the hydraulic clamp spec., use connection port of Rc3/8 for different diameter.  
Using the hose equivalent to 3/8 is recommended.

### 8-2-3. Rotary joint specifications (Only TT182)

Do not change the mounting direction of the piping block.

When the piping block is removed, hydraulic oil mixes with lubrication oil.

Moreover, when the hydraulic oil is reduced, a brake alarm occurs.

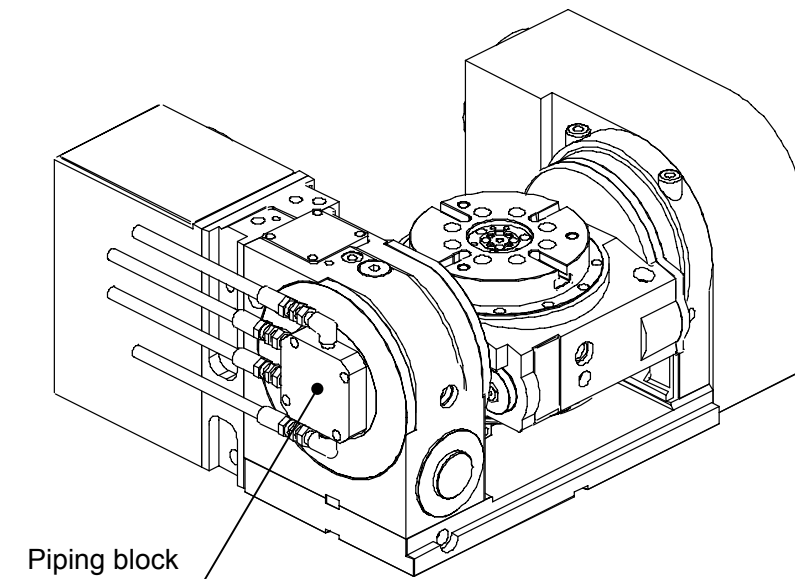

**Fig.2**

### **8-3. Air Relief**

Be sure to perform air relief when lubrication oil is supplied after disassembling the table or the brake alarm occurs. If air is not sufficiently exhausted, the alarm occurs because of clamp failure.

#### **8-3-1. Pneumatic clamp system (See Fig.3-1: TT182)**

- 1) Tilt the rotating axis  $90^\circ$  from the horizontal state of table ( $0^\circ$ ) to make the table vertically.
- 2) Move the piston of the cylinder for the tilting axis or rotating axis (hereinafter referred to as piston) to the returned edge. When the air is supplied with the solenoid valve ON at excitation unclamp specification and with the solenoid valve OFF at excitation clamp specification, the piston moves the returned edge.
- 3) Remove the hexagon socket head taper screw plug ② and the tank cover on air hydraulic part (hereinafter referred to as cover) ① and fill the oil tank fully with the specified hydraulic oil.
- 4) Check that the hole of hexagon socket head taper screw plug ② is full with the lubrication oil and tighten the hexagon socket head taper screw plug ②.

Air relief on tilting axis side

- 1) Repeat the clamp-unclamp operation, and in the clamp mode, use a hexagon bar spanner to loosen the air relief plug ③ a little bit to remove the air while lightly pushing

the plug, and then retighten it while still clamped.

- 2) Repeat the above operation until there are no bubbles (air) in the hydraulic oil leaking from the air relief plug ③.

#### Air relief on rotating axis side

- 1) Perform the air relief with the air relief plug ④ by the above steps 1) and 2).
- 2) After that, perform the air relief with the air relief plug ⑤ by the same steps.
- 3) When the air relief is finished, fill the hydraulic oil into the air hydraulic oil tank to maximum oil level in the oil gauge on the tilting axis base side face.
- 4) When the work is finished completely, check the O-ring on cover ① mounting part is not run off from the groove before mounting the cover ①.
- 5) Start the NC rotary table, and confirm that the table clamp alarm does not light up on either the tilting axis side or the rotating axis side. If the alarm lights up, it means the air has not been completely removed, and therefore the required pressure has not been reached. Accordingly, you need to repeat the procedures to remove the air from the side that triggered the alarm.



- 1) When the air relief plug is too loosened, there is a possibility that the air relief plug flies out and hydraulic oil spills out. Slightly push the air relief plug with the hexagon bar spanner and cover it with rags so as not to fly out the plug and spill out the hydraulic oil.
- 2) Once some air has been removed, leave it in clamp/unclamp for five seconds or longer and then remove the air again until there is none left.
- 3) When you loosen the air relief plug, leave it in clamp mode until the plug is tightened again. If you switch it to unclamp mode while the plug is still loose, there is danger of air being sucked in.
- 4) During air relief, since oil becomes short, bleed the air, filling the oil tank with oil.
- 5) After finishing the air relief, cleanly wipe oil spilled around the unit with a waste cloth.
- 6) Fill the oil tank with the hydraulic oil to a high level of oil gauge.

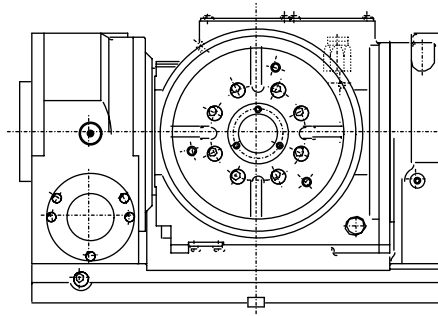

**Front View of Vertical Table Face**

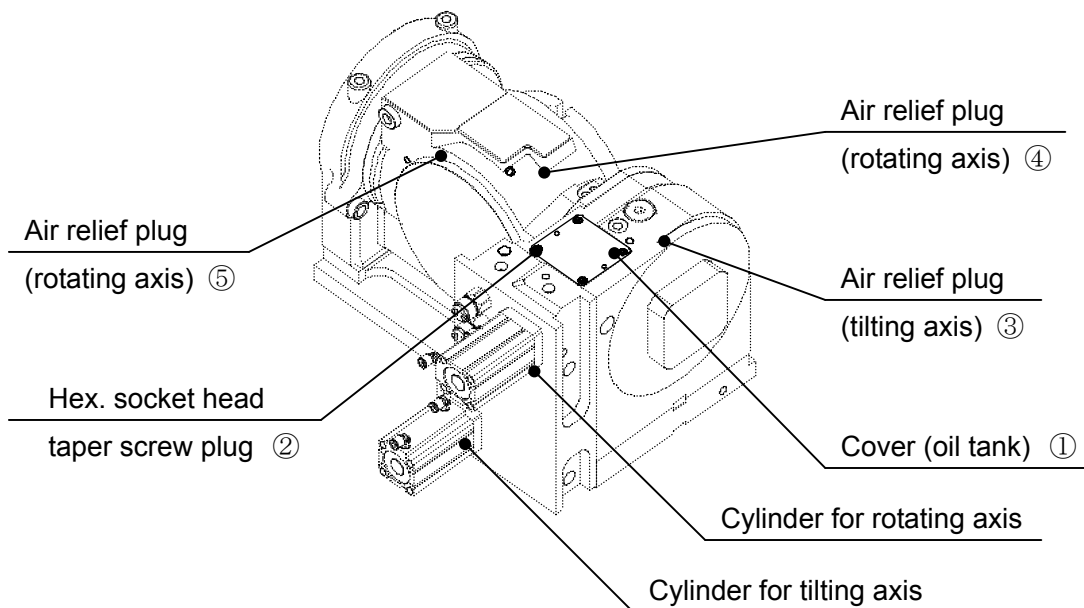

**Fig. 3-1 (TT182)**

**8-3-2. Pneumatic clamp system (See Fig.3-2: TW182)**

- 1) Tilt the rotating axis 90° from the horizontal state of table (0° ) to make the table vertically.
- 2) Move the piston of the cylinder for the tilting axis or rotating axis (hereinafter referred to as piston) to the returned edge. When the air is supplied with the solenoid valve ON at excitation unclamp specification and with the solenoid valve OFF at excitation clamp specification, the piston moves the returned edge.
- 3) Remove the tank cover ① on the air hydraulic part (hereinafter referred to as the cover), hexagon socket head taper screws ②, ③, ⑤ and ⑥ and fill the oil tank with a specified hydraulic oil fully.
- 4) Check that drilling holes of hexagon socket head taper screws ②, ③, ⑤ and ⑥ are

filled with hydraulic oil and tighten hexagon socket head taper plugs ②, ③, ⑤ and ⑥.

#### Air relief on tilting axis side

- 1) Advance the piston to clamp it and push air relief plug ④ slightly with the hexagon bar spanner to bleed air by loosening the air relief plug a little with the plug covered with a waste cloth.
- 2) Repeat clamp and unclamp motions until no bubble (air) mixed into oil comes on from air relief plug ④ and tighten the air relief plug ④ again.

#### Air relief on rotating axis side

- 1) Bleed air from air relief plug ⑦ according to the same procedure as items 1) and 2).
- 2) After that, bleed air from air relief plug ⑧ according to the same procedure.
- 3) After finishing air bleeder, replenish the air hydraulic oil in the tank until the hydraulic oil level reaches a proper position of the oil gauge on the tilting axis base side face.
- 4) After finishing all works, check that the O-ring on cover ① mounting part does not run off from a groove before mounting cover ① again.



- 1) When the air relief plug is too loosened, there is a possibility that the air relief plug flies out and hydraulic oil spills out. Slightly push the air relief plug with the hexagon bar spanner and cover it with rags so as not to fly out the plug and spill out the hydraulic oil.
- 2) For air relief, although unclamp time may be short, take a clamp time of 5 seconds or more.
- 3) During air relief, since oil becomes short, bleed the air, filling the oil tank with oil.
- 4) After finishing the air relief, cleanly wipe oil spilled around the unit with a waste cloth.
- 5) Since the oiling method of hydraulic oil differs by the machine number, refer to item 5-4.

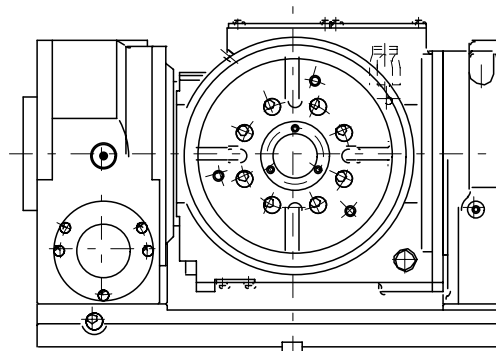

**Front View of Vertical Table Face**

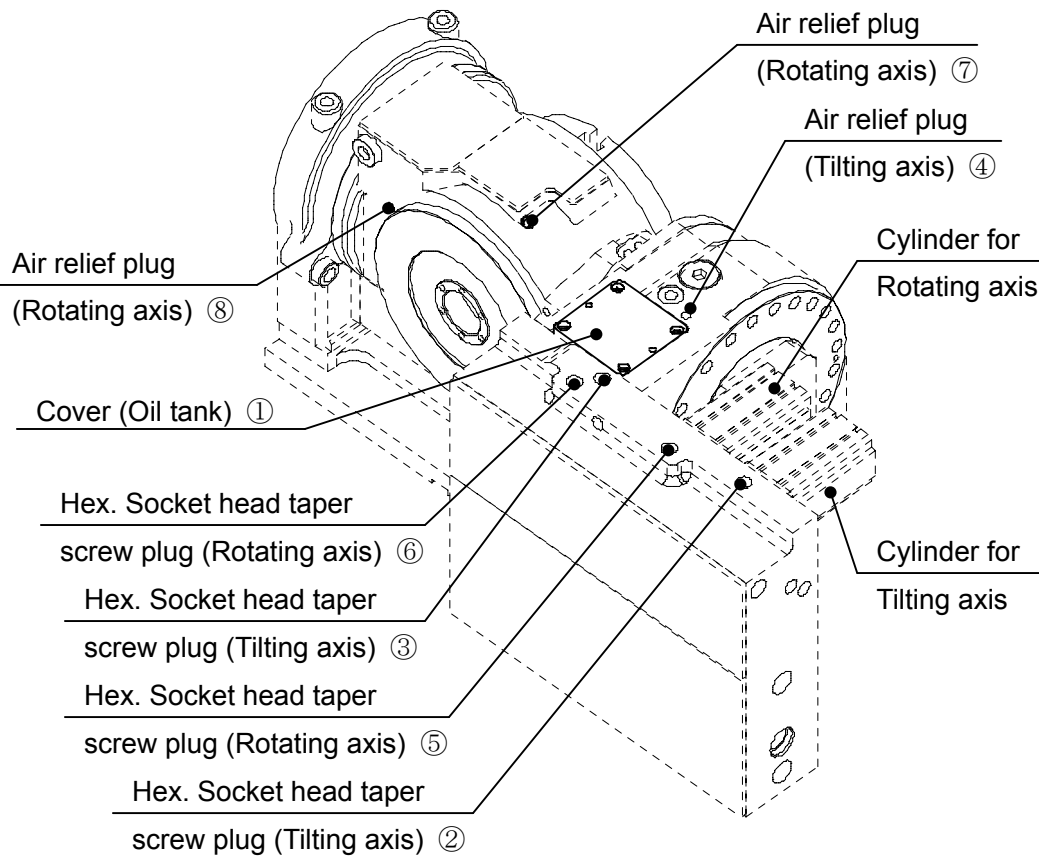

**Fig.3-2 (TW182)**

**8-3-3. Hydraulic clamp system (See Fig.4-1, Fig4-2)**

Tilt the rotating axis 90° from the horizontal state of table (0° ) to make the table vertically.

Air relief on tilting axis side

- 1) Clamp the NC rotary table (apply hydraulic pressure).
- 2) Push the air relief plug ① with the hexagon bar spanner slightly and cover it with a waste cloth before bleeding air by loosening the plug slightly.

- 3) When bubbles (air) mixed with oil does not run over the air relief plug ①, tighten the air relief plug ① under a clamp state.

#### Air relief on rotating axis side

- 1) Perform the air relief with the air relief plug ② by the above steps 1) and 2).
- 2) After that, perform the air relief with the air relief plug ③ by the same steps.



- 1) When the air relief plug is too loosened, there is a possibility that the air relief plug flies out and hydraulic oil spills out. Slightly push the air relief plug with the hexagon bar spanner and cover it with rags so as not to fly out the plug and spill out the hydraulic oil.
- 2) When you loosen the air relief plug, leave it in clamp mode until the plug is tightened again. If you switch it to unclamp mode while the plug is still loose, there is danger of air being sucked in.
- 3) During air bleeding, since oil for the pump unit becomes short, it is necessary to fill the oil tank with the hydraulic oil.
- 4) After finishing the air relief, cleanly wipe oil spilled around the unit with a waste cloth.
- 5) Take care so as not reduce pressure during clamp.

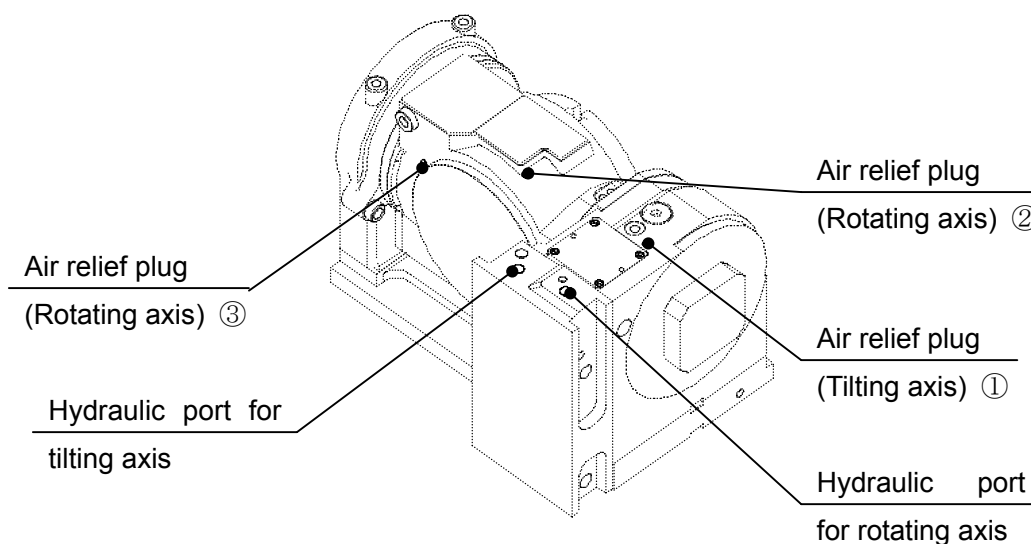

### Hydraulic Pressure Spec.

**Fig.4-1 (TT182)**



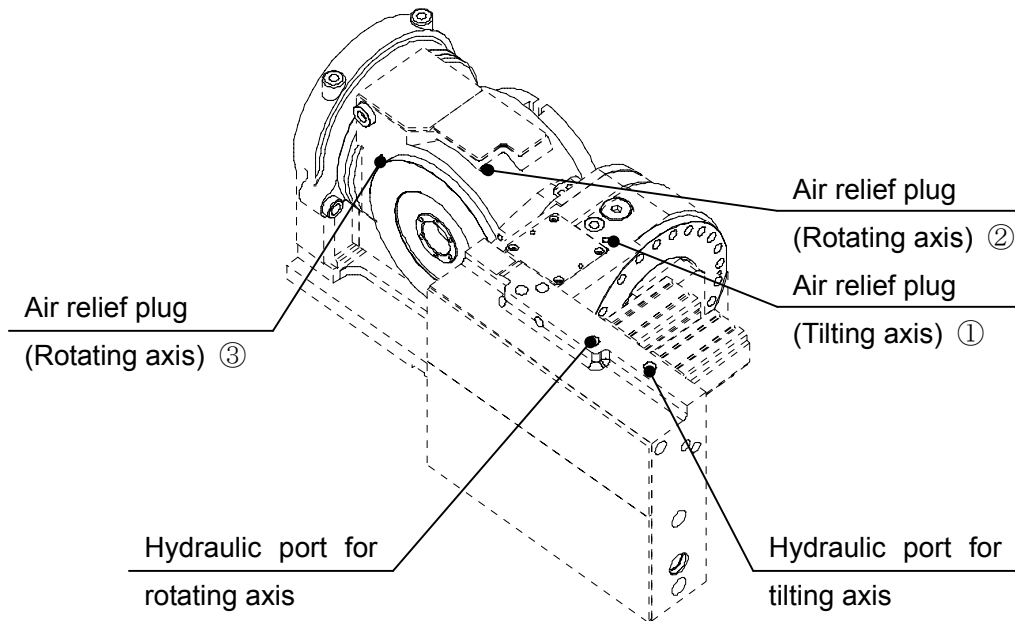

### Hydraulic Pressure Spec.

**Fig.4-2 (TW182)**

#### **8-3-4. Maintenance inspection**

- 1) Air may mix in oil during operation because the piping joint, each plug, etc., are loosened. At this time, bleed the air according to the procedures of the above.
- 2) The hydraulic oil is deteriorated when it is used for a long period of time. Replace the oil every year.
- 3) With the NC rotary table operated after ready for start-up, if a brake alarm occurs, check the air bleeding for confirmation.

#### **8-4. Air purge**



Dew drops may occur in the motor case by ambient environment. In this case, each component in addition to electric apparatus will fail or rust will occur. Therefore, the air is purged and exhausted from the air purge exhaust port.

(Air Hydraulic pressure system)

The air purge is performed by air branched in the NC rotary table from air used for clamp. Thus, air is used in the motor case from joint with hole of 0.4mm.

Be sure to supply clean air passing through the filter (air filter, mist separator, regulator and

drain catcher).

If moisture, oil content, etc., are mixed in the air, its air is entered in the motor case, thus damaging the equipment. The air in the motor case is exhausted from the air purge exhaust port.

If the air purge exhaust port is closed, condensed drops are not exhausted and pressure is kept in the motor cover as is, thus causing in motor case damaging and motor malfunction. Therefore, never close the air purge exhaust port. When exhausting air, although any exhaust sound occurs, there is no problem.

(Hydraulic pressure system)

Since an exclusive supply port for air purge is provided, be sure to supply clean air as well as the type of air pressure specifications (Pneumatic: 0.5MPa).

When performing the air purge, block M5 screw hole of air purge exhaust port as shown in the outside view with the cross recessed round head screw M5 and the seal washer 5. (If not blocked, coolant may enter in the motor case.)

### 8-5. Checking device for Clamp/Unclamp

To proceed a secure work, be sure to use Clamp/Unclamp confirmation signals. (See Fig.5-1, Fig.5-2)

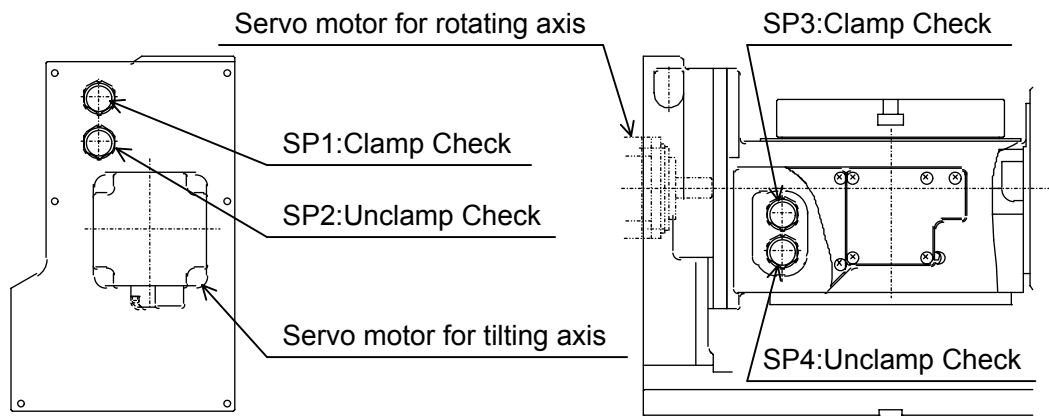

Inside view of tilting axis motor case

Inside view of rotating axis table rear base

**Fig.5-1 (TT182)**

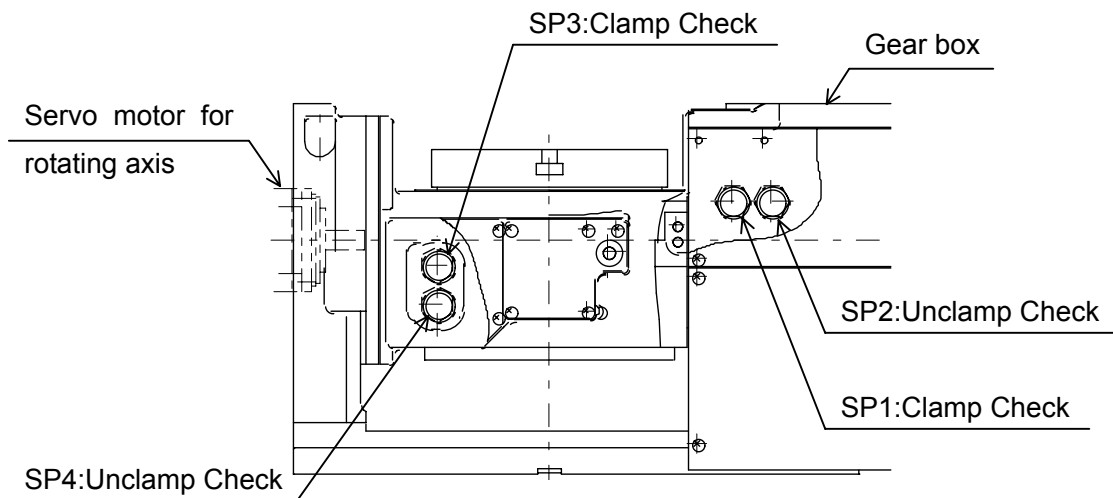

**Fig.5-2 (TW182)**

The set pressure values of pressure switches for air/hydraulic pressure clamp specifications are as follows:

Clamp check (SP1, SP3)	2.16MPa (176 112 200)
Unclamp check (SP2, SP4)	0.4MPa (176 120 200)

### 8-6. Solenoid valve for Clamp/Unclamp

In case of NC rotary table made by air hydraulic clamp specifications, the solenoid valve is incorporated. Since the following piping is used as standard, take care when electric cables are connected.

Refer to outside view and item 23-2.

(Excitation Unclamp Spec.)

Solenoid: ON ... Table Unclamp

Solenoid: OFF ... Table Clamp

(Excitation Clamp Spec.)

Solenoid: ON ... Table Clamp

Solenoid: OFF ... Table Unclamp



In hydraulic clamp specifications, the solenoid valve is not incorporated.

When the solenoid valve is mounted outside of NC rotary table, route cable at the above specification.

## 9. Mounting of Workpiece

Mount the workpiece securely to increase accuracy.



If the workpiece is not mounted securely, accuracy becomes not only worse but also the machine and tools are damaged. Therefore, take extreme care because it also causes an accident resulting in injury or death in the worst case.



When the workpiece that flatness and straightness are not obtained is tightened as is, the workpiece or the rotary table may be distorted, thus resulting in low accuracy or unevenness rotation. In such case, insert the shim(s) between the workpiece and the rotary table.



When the workpiece is tightened, fix the workpiece equally and securely on the rotary table as much as possible.

## 10. Maintenance Work

### 10-1. Corrective Action in Case of Failure, and Disassembly

See the “Troubleshooting” if a failure occurred in the unit due to any reason. Also, for the disassembly procedure when performing the maintenance work, refer to the parts list and the procedure given in the corresponding maintenance item.

### 10-2. Before Performing Maintenance Work

When performing the maintenance work, shut off the power (primary power supply) of the machining center or Kitagawa’s own controller to set the pressure adjusting valve of air combination that supplies the air to the NC rotary table to 0 MPa or shut off the power of the air compressor to exhaust the compressed air, so as to stop the supply of the working fluid.



Perform the maintenance work with the workpiece removed. Performing the work with the workpiece left on the table may cause the workpiece to be dropped out, resulting in injuries.



Appropriate value in each maintenance item has been set for smooth function of each device, and thus you should observe it. Performing the maintenance work without observing the appropriate value may cause NC rotary table to fail or each device to be damaged.



Clamp the table clamp device of NC rotary table when removing the workpiece.

## 11. Backlash Adjustment of Worm Gears

The worm shaft and worm wheel are made of the special materials and they are accurately machined.

The dual lead worm system is adopted for eliminating the backlash of worm gear. It changes the lead of right and left teeth of worm shaft a little and adjusts the backlash for the worm wheels by shifting this worm shaft in the axis direction.

This dual lead worm system can adjust the backlash finely without changing an ideal engagement state and it is theoretical and most secure backlash adjustment method.

Although the backlash of worm gear has already been adjusted before shipping, it is necessary to adjust the backlash when the machine is operated for a long period of time.

The proper values for backlash are shown in the following list. These are values when the machine is cooled. Thus, they are values after interrupting for a long period of time.

Consequently, when the machine is operated for a long period of time, the backlash becomes small in comparison with the following values.

### NOTICE

If backlash is too small, the worm gear will cause seizing.

#### ○ Adequate Backlash

Table model: TT182, TW182	Circular arc length at peripheral table position ( $\mu\text{m}$ )	Converted angle (sec.)
Rotating axis	13~38	30~88
Tilting axis	7~12	15~29

When adjusting the backlash, measure the current backlash by the following method. After that, adjust it.

### 11-1. Backlash measuring method of worm gear of rotating axis

- 1) Set the dial gauge the periphery of T-slot on the table top face.
- 2) Read the value of dial gauge at the position where the table stops after rotating the table slowly in one way with the flat steel or round bar inserted in T-slot on the top face of table (with worm wheel gear tooth attached). At this time, for the torque added to the table, refer to the list created later. Next, rotate the table under the same condition in the reverse direction to read the value of dial gauge. This difference of measured values is the backlash.
- 3) Perform the above measurement at 8 positions by rotating the table and compare them

with the above adequate values. (See Fig.6)

$$T = F \times L$$

T: Torque (N·m)

F: Effort force (N)

L: Distance from table center to point to add force F (m)

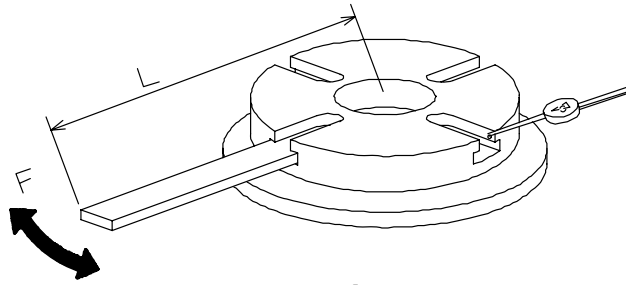

**Fig.6**

### 11-2. Backlash measuring method of worm gear of tilting axis

- 1) Set the dial gauge the periphery of the table top face.
- 2) Read the value of dial gauge at the position where the table stops after rotating the tilting body slowly in one way with the flat steel or round bar inserted in eye bolts screwed in tap holes on the table back face (with worm wheel gear tooth attached). At this time, for the torque added to the tilting body, refer to the list created later. Next, rotate the tilting body under the same condition in the reverse direction to read the value of dial gauge. This difference of measured values is the backlash. (See Fig.7)

$$T = F \times L$$

T: Torque (N·m)

F: Effort force (N)

L: Distance from table center to point to add force F (m)

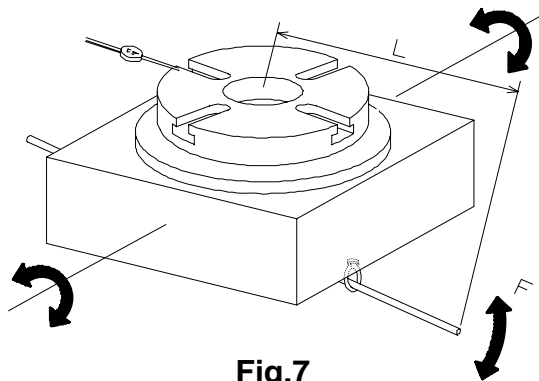

**Fig.7**

Table type		TT182, TW182
Torque	Rotating axis	30
T (N·m)	Tilting axis	9

### 11-3. Backlash adjusting method of rotating axis worm gear (See Fig.8)

- 1) Drain lubrication oil from the rotating axis lubrication oil drain port. (See the outside view.)
- 2) Remove the cover ①.
- 3) Remove hexagon socket head set screws ③ which fix lock nut ② and bearing case ⑤ before loosening hexagon socket head screw ④.
- 4) The lock nut ② is engaged with the bearing case ⑤ by M42, P1.5 screw. Since eight 5mm drill holes are provided on the periphery of the lock nut ② and the bearing case ⑤, fix the bearing case ⑤ with a proper round bar before loosening the lock nut ②.
- 5) When rotating and advancing the bearing case ⑤ clockwise by using the above 5mm drill hole, the backlash becomes small.
- 6) After adjusting the backlash, fix the bearing case ⑤ and tighten the lock nut ② securely. Then, measure the backlash again and check that it is proper.
- 7) After checking that the backlash is proper, mount the cover ① again to the original position with hexagon socket head set screws ③ and ④.

#### NOTICE

Each interval between the hole and the hole of periphery of bearing case is  $45^\circ$ . When rotating the bearing case  $45^\circ$ , the backlash of about  $8\mu\text{m}$  is reduced at arc length on the peripheral position of table.



#### CAUTION

Adjust the backlash slowly and carefully without adjusting the backlash at a time.



#### CAUTION

When mounting the cover ①, do not damage O-ring ⑥.



#### CAUTION

When mounting the hexagon socket head set screws ③ and ④, make sure to put the coat seal agent on the thread part of set screws and tighten them firmly.



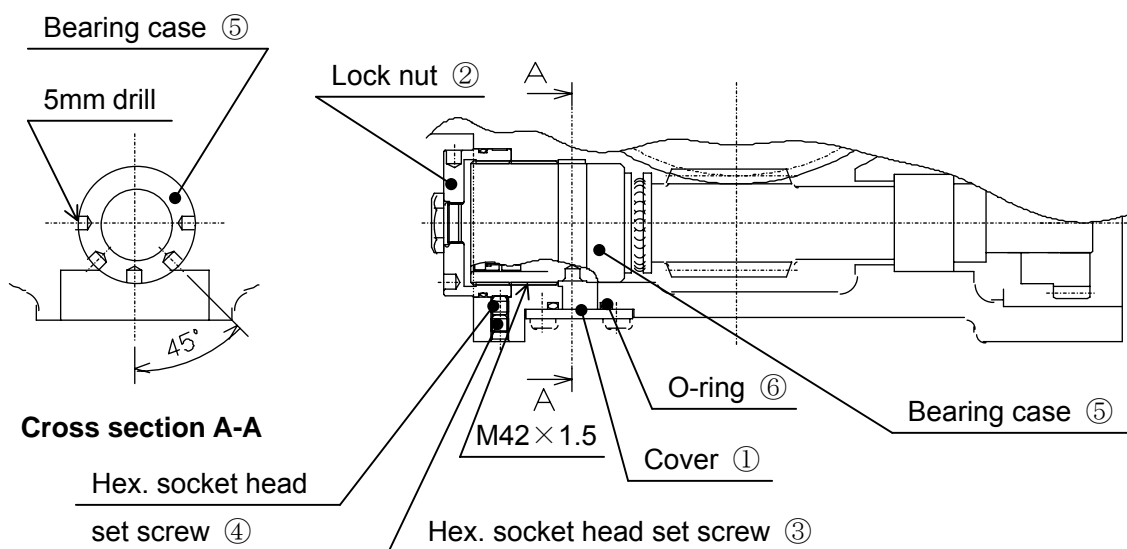

**Fig.8**

#### 11-4. Backlash adjusting method of tilting axis worm gear (See Fig.9)

- 1) Remove the workpiece, jig, etc. on the table before adjusting and horizontalize the table.
- 2) Drain lubrication oil from the tilting axis lubrication oil drain port. (See outside view.)
- 3) Remove cross recessed round head screws ⑥ and ⑦ which fix cover ① to remove the cover ① by using two punched taps ⑦ on a diagonal line.
- 4) The bearing case ④ is positioned by adjusting screws ② and hexagon socket head cap screws ③.
- 5) When loosening eight adjusting screws ② to the same amount and tightening four hexagon socket head cap screws ③ to the same amount, the bearing case ④ advances and the backlash becomes small.

### NOTICE

The rotating angle of adjusting screw to reduce the backlash to 0.01mm is as follows:

Type	TT182, TW182
Return angle	About 90°

When adjustment is finished, mount the workpiece, jig, etc. by the reverse procedures as the above and tighten bolts securely. After mounting, measure the backlash again on the periphery of table at the same position as the position before adjusting, and check that the measured value is proper.

**NOTICE**

Adjust the backlash slowly and carefully without adjusting the backlash at a time.

**CAUTION**

When mounting the cover ①, do not damage O-ring ⑤.

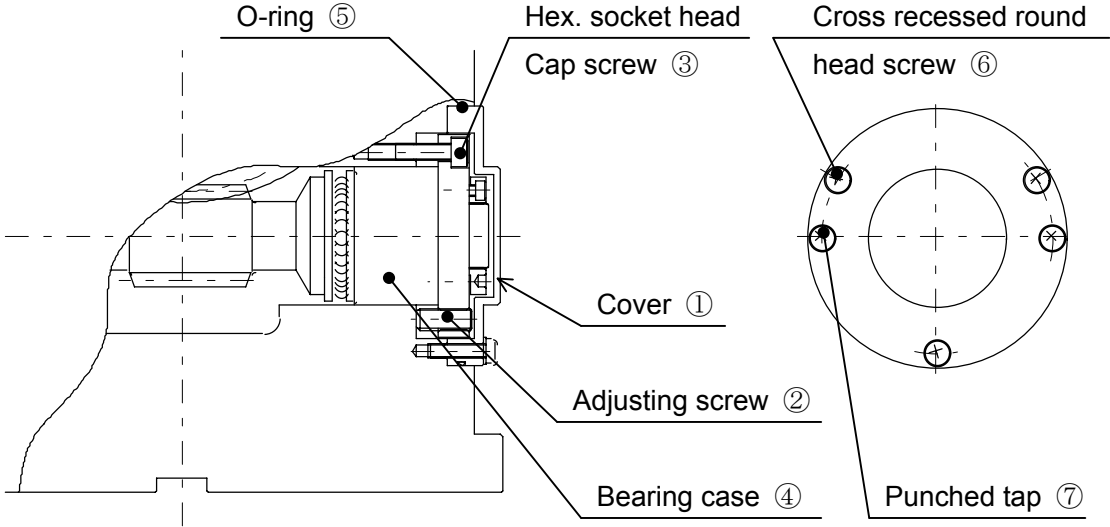

**Fig.9**

## 12. Backlash Adjustment of Spur Gears

### 12-1. Backlash adjusting method of rotating axis drive spur gears

(See Fig.10)

The backlash between Z1 – Z2 spur gears is adjusted by changing a center distance after adjusting the motor position with hexagon bolt ① for the stopper attached to the motor side.

- 1) Adjust the backlash where the table surface is horizontal.
- 2) Drain lubrication oil from the rotating axis lubrication oil drain port (See outside view).
- 3) Slightly loosen four mounting bolts ③ which fix the motor.
- 4) Rotate hexagon bolt for stopper ② clockwise and hexagon bolt for stopper ① counterclockwise slowly and move the motor so that the backlash becomes zero (0) approximately.
- 5) Rotate the hexagon bolt for stopper ② to distance moving the motor so that gears will be engaged at proper backlash (0.02~0.04mm).

Moreover, since the thread pitch for hexagon bolts for stopper ① and ② is 1.0, when rotating hexagon bolts for stopper ① and ②  $10^\circ$  (1/36 rotation), the backlash varies 0.02mm.

- 6) Pushing up the motor by rotating the hexagon bolt for stopper ①, eliminate gap between the motor and the hexagon bolt for stopper ②. (At this time, check the motor movement with the dial gauge attached to the motor side.)
- 7) With the motor attached to hexagon bolts for stopper ① and ②, tighten four mounting bolts ③ that loosened slightly.
- 8) After adjusting, run the motor from slow speed to high speed to check that abnormal noise does not occur.



When mounting the motor, take care so that O-ring ④ will not be damaged.

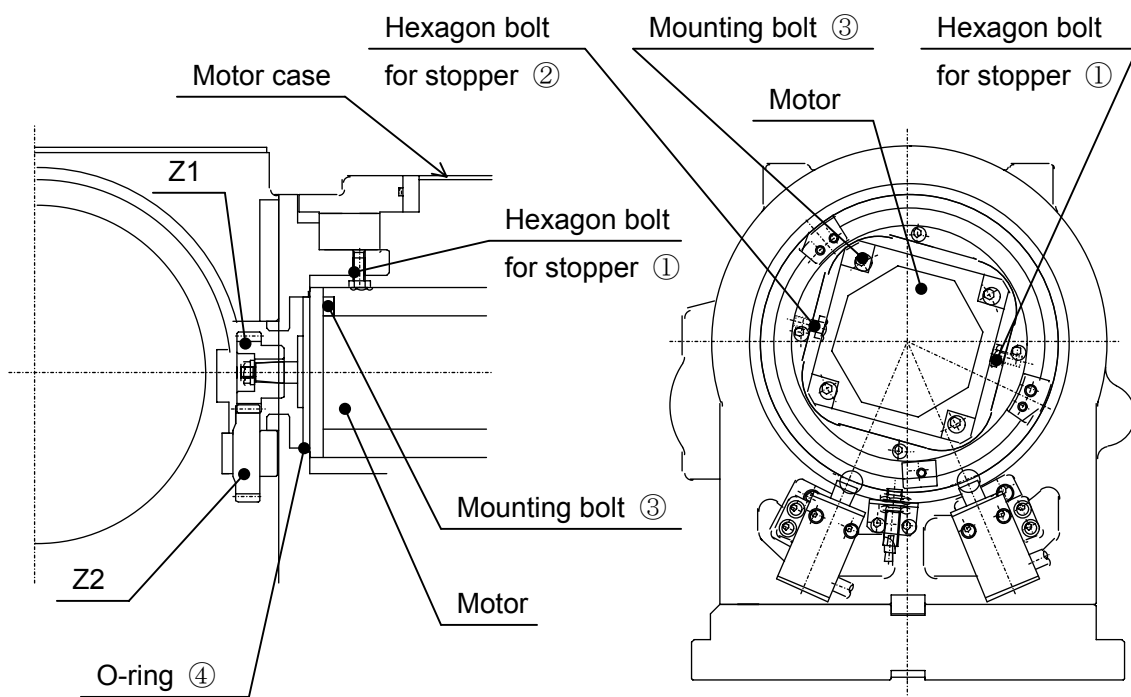

**Fig.10**

## 12-2. Backlash adjusting method of tilting axis drive spur gears

(See Fig.11-1: TT182)

- 1) Drain lubrication oil from the tilting axis lubrication oil drain port (See outline drawing).
- 2) Slightly loosen four mounting bolts ③ which fix the motor.
- 3) Loosen nut ⑤ and rotate hexagon bolts for stopper ① and ② to lower the motor until the backlash become zero (0) approximately.
- 4) To make the backlash to zero (0) approximately, loosen hexagon bolt for stopper ② and then, tighten the hexagon bolt for stopper ① slowly.
- 5) Proper backlash between gears is 0.02~0.04mm. Since the thread pitch for hexagon bolts for stopper ① and ② is 1.0, when rotating hexagon bolts for stopper ① and ② 10° (1/36 rotation), the backlash varies 0.02mm.  
At this time, touch the dial gauge to the motor side to check the movement of motor.
- 6) With the motor attached to hexagon bolts for stopper ① and ②, tighten four mounting bolts ③ that loosened slightly.
- 7) After adjusting, run the motor from slow speed to high speed to check that abnormal noise does not occur.



When mounting the motor, take care so that O-ring ④ will not be damaged.

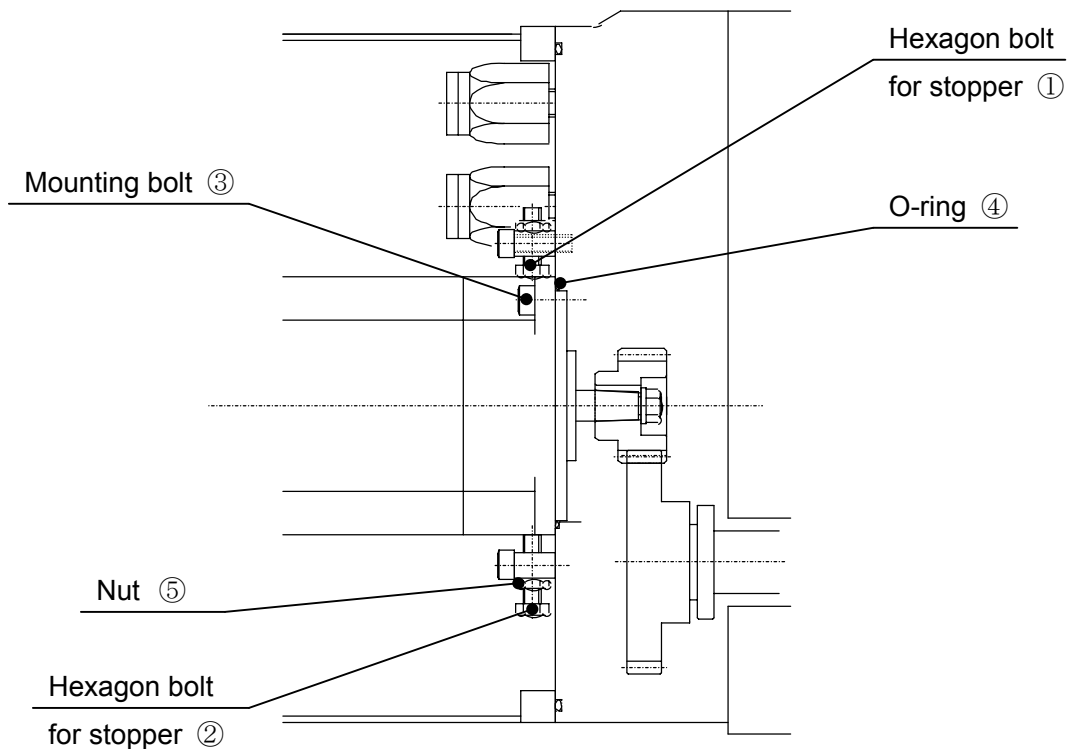

**Fig.11-1 (TT182)**

### **12-3. Backlash adjusting method of tilting axis drive spur gears (See Fig.11-2: TW182)**

The adequate backlash of the spur gear is 0.02~0.04mm. If the backlash amount differs from the adequate backlash materially, it is necessary to adjust the backlash.

#### **A) Spur gear Z1 and spur gear Z2**

The backlash between spur gear Z1 ① and spur gear Z2 ② is adjusted by changing distance between shafts, rotating the eccentric shaft ⑥.

- 1) Drain lubrication oil from the drain port for the gear box. (See the outline drawing.)
- 2) Remove cover ④.
- 3) Fix spur gear Z2 ② and touch the dial gauge to a tooth face of spur gear Z1 ① to measure the backlash amount.
- 4) Loosen hexagon socket head cap screw ⑦ and rotate eccentric shaft ⑥ to adjust the center distance between spur gear Z1 ① and spur gear Z2 ②, checking the backlash amount with the dial gauge.
- 5) The backlash amount has been set to the adequate value before shipping, and the matchmark of a gear box and the matchmark of the eccentric shaft have also been matched.

B) Spur gear Z2 and spur gear Z3

The backlash between spur gear Z2 ② and spur gear Z3 ③ is adjusted by changing distance between shafts after adjusting a motor position with hexagon bolts ⑩ for the stopper touched to servo motor ⑫ side.

- 1) Fix spur gear Z2 ② and touch the dial gauge to a tooth face of spur gear Z3 ③ to measure the backlash amount.
- 2) Remove motor case ⑨.
- 3) Loosen all four hexagon bolts ⑩ for the stopper slightly and run the motor slowly until the backlash amount becomes zero (0) approximately in order to adjust the motor position.
- 4) Since the screw pitch of hexagon bolt ⑩ for the stopper is 1.0, when rotating 10" (1/36 rotation), the backlash varies 0.02mm.
- 5) With hexagon bolts ⑩ for the stopper touched certainly to the motor, tighten four hexagon socket head cap screws ⑪ securely and check the backlash amount again with the dial gauge.
- 6) After adjusting, run the motor from slow speed to high speed to check that noise does not occur.



When mounting cover ④ and motor case ⑨ again, and motor ⑫ is moved, take care so that O-rings ⑤, ⑧ and ⑬ are not damaged.

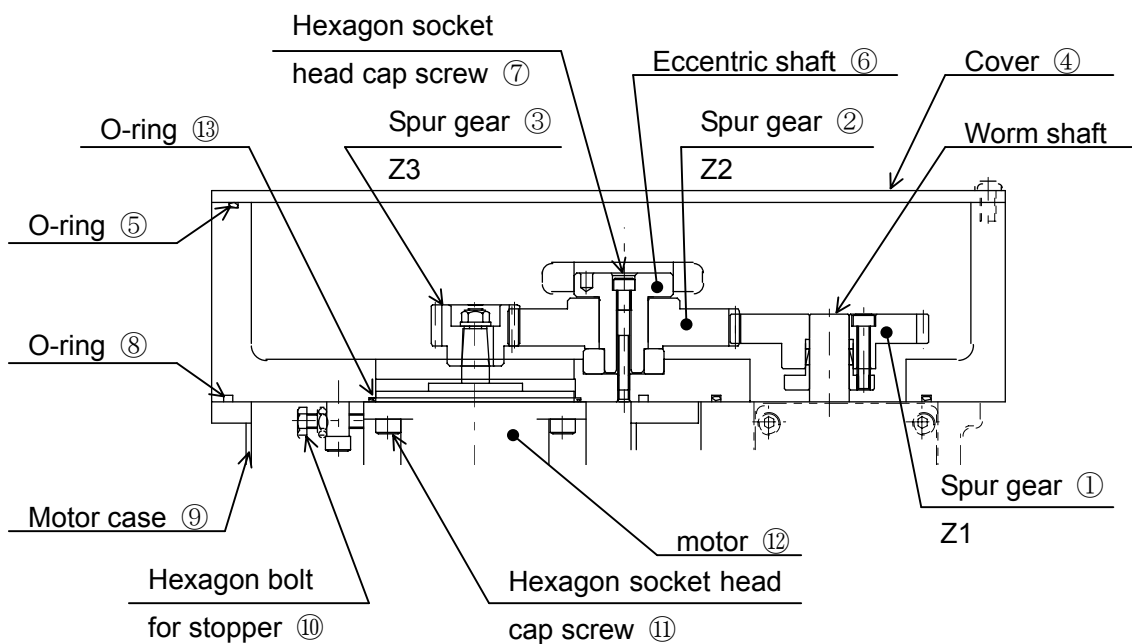

Fig.11-2

## 13. ZRN (Zero Return) Device

\*\*\*\*\*

The contents of this item are unnecessary for the NC rotary table of Kitagawa's controller spec. and 4th and 5th axes spec. which don't have a Proximity switch for ZRN deceleration.

Machine zero position of this unit which set at shipment from factory is memorized due to the specification of servo motor with absolute encoder. Accordingly this unit does not have machine zero position device like as proximity SW and Dog.

When changing machine zero position, instruction manual of controller (article for setting of machine zero position) would be referred.

\*\*\*\*\*

### 13-1. Rotating axis ZRN device (See Fig.12)

The rotational direction for ZRN is clockwise (CW).

The dog for ZRN deceleration is mounted inside of table and it can be mounted on the circumferential position. When a zero position is changed or return rotation direction is changed counterclockwise, since it is necessary to change the dog position, the following procedure is recommended for adjustment.

- 1) Drain lubrication oil from the tilting axis lubrication oil drain port (See outside view).
- 2) Remove covers ① and ④.
- 3) When the cover ④ is removed, since a dog adjusting hole is found, rotate the table with the manual pulse generator or JOG key to the place where the dog can be found.
- 4) Loosen set screws ③ which fix the dog ②.
- 5) Move the dog ② to the proper position.
- 6) After adjusting the dog position, tighten set screws ③ securely.



When mounting the cover again after adjusting the dog position, take care so that O-ring is not damaged.

The proximity switch is used as the dog detecting sensor. The gap between the dog and the proximity switch is set to about 0.75mm. (Thread pitch for mounting the proximity switch is 1mm.) The proximity switch with a lamp is used. When the dog is detected, since the lamp goes off, use the proximity switch as a target when the dog position is adjusted.

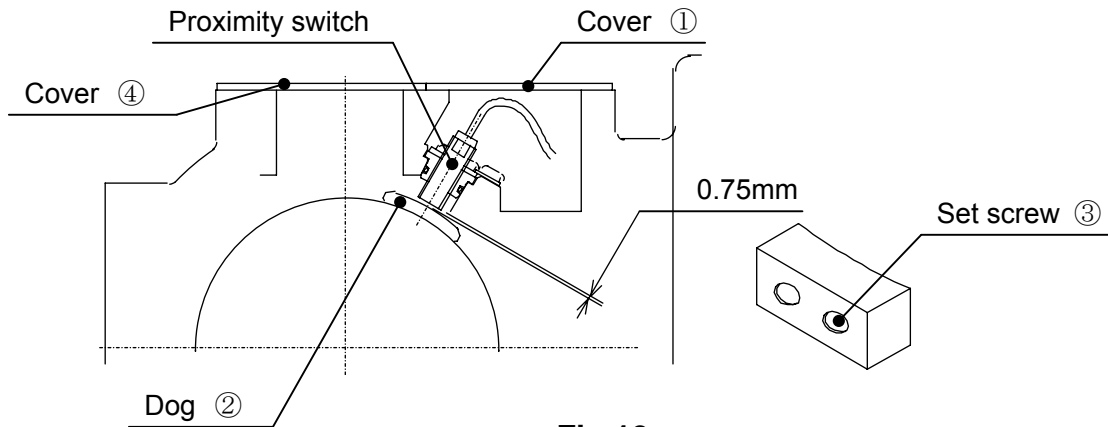

**Fig.12**

**13-2. Tilting axis ZRN device (See Fig.13-1)**

- 1) The ZRN deceleration dog and the proximity switch are contained into the rotating axis motor case.
- 2) In the standard specification, the horizontal table face position is regarded as an origin. The proximity switch A ④ detects dog A ①.
- 3) When the vertical table face position is regarded as an origin, dog A ① must be changed to “Dog A mounting position at vertical origin”.



## 14. Tilting Axis Over Travel Stop Device (See Fig.13-1, Fig.13-2)

### 14-1. Tilting axis over travel stop device

- 1) Remove the cover on the motor case side.
- 2) The dog and the limit switch of emergency stop for the tilting axis stroke limit are contained into the rotating axis motor case.
- 3) The limit switch B ⑤ detects dog B ② of stroke limit on the horizontal table face position side.
- 4) The limit switch B ⑥ detects dog C ③ of stroke limit on the vertical table face position side.
- 5) The angle until the emergency stop mode is applied to the machine from the horizontal table face is about  $35^{\circ}$  . The angle until the emergency stop mode is applied to the machine from the vertical table face is about  $20^{\circ}$  .



The angle values of  $35^{\circ}$  or more from the horizontal table face and  $20^{\circ}$  or more from the vertical table face cannot be set.



The angle may be limited within a standard value in advance by customer conditions or to prevent the interference with the jig, workpiece, etc. In this case, it cannot be set more than the limited angle.

### 14-2. Adjusting methods of dog for vertical over-travel

- 1) When the customer will change position of dog B ② according to the shape of workpiece and jig, loosen hexagon socket head set screws which fix the dog and slide the dog B ② counterclockwise (CCW) along the groove with the hexagon wrench still inserted in order to recess once.
- 2) Rotate the tilting axis to the tilting angle to be set in the minus direction with the manual pulse generator or the JOG key, checking that it does not interfere with the jig or workpiece.
- 3) After rotating the rotary table to the desired tilting angle, insert the hexagon wrench in the dog B ② and slide the dog B ② in the reverse direction clockwise (CW) before fixing until the over-travel alarm lamp lights.
- 4) After fixing the dog B ②, rotate the tilting axis again with the manual pulse generator or the JOG key and check that the tilting axis stops at the desired tilting angle position and

alarm lamp lights.

- 5) After adjusting, mount the side cover of motor case on the rotating axis side.



When mounting the cover, coat the cover with liquid packing (liquid gasket 1216 made by THREE BOND) evenly.

### 14-3. Adjusting methods of dog for horizontal over-travel

- 1) When the customer will change position of dog C ③ according to the shape of workpiece and jig, loosen hexagon socket head set screws which fix the dog and slide the dog C ③ clockwise (CW) along the groove with the hexagon wrench still inserted in order to recess once.
- 2) Rotate the tilting axis to the tilting angle to be set in the plus direction with the manual pulse generator or the JOG key, checking that it does not interfere with the jig or workpiece.
- 3) After rotating the rotary table to the desired tilting angle, insert the hexagon wrench in the dog C ③ and slide the dog C ③ in the reverse direction counterclockwise (CCW) before fixing until the over-travel alarm lamp lights.
- 4) After fixing the dog C ③, rotate the tilting axis again with the manual pulse generator or the JOG key and check that the tilting axis stops at the desired tilting angle position and alarm lamp lights.
- 5) After adjusting, mount the side cover of motor case on the rotating axis side.



When mounting the cover, coat the cover with liquid packing (liquid gasket 1216 made by THREE BOND) evenly.

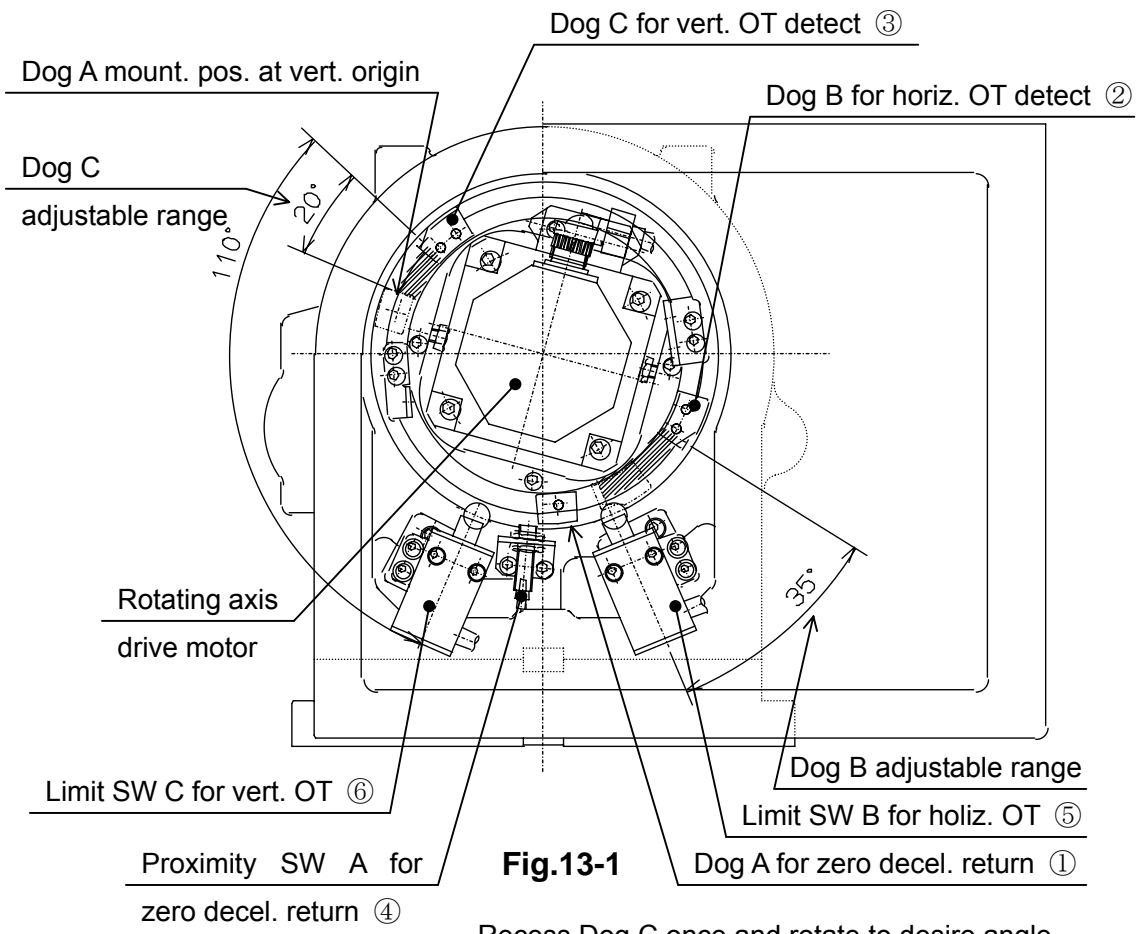

**Fig.13-1**

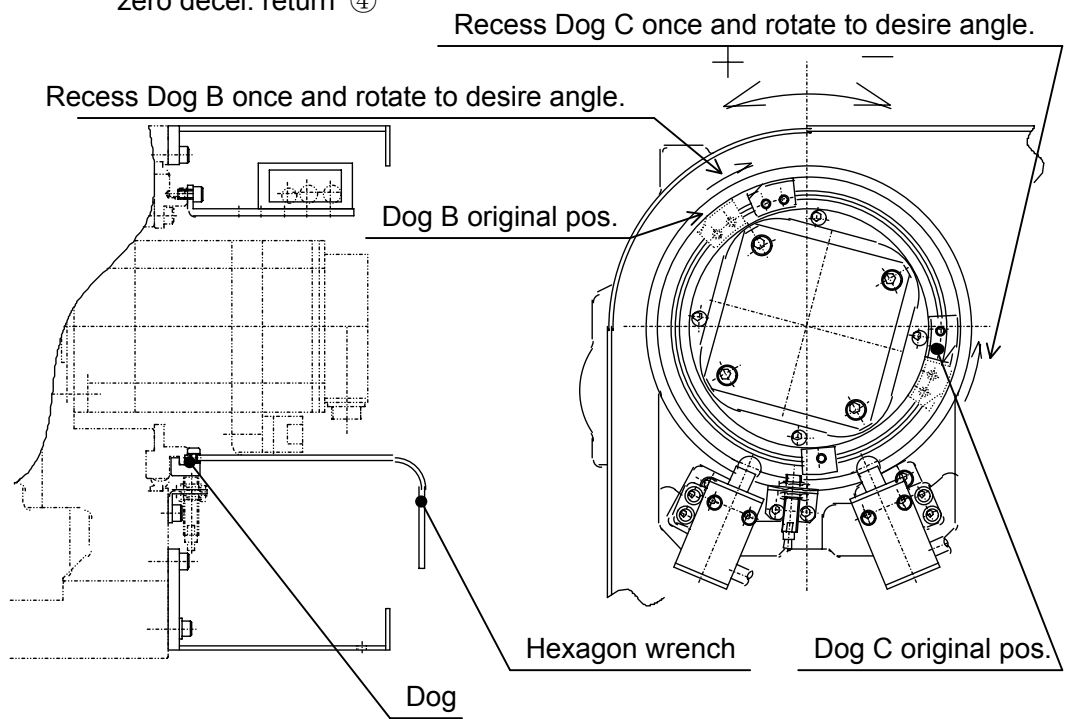

**Fig.13-2**

## 15. Motor Case

### 15-1. To remove motor case (See Fig.14)

When removing the motor case of tilting axis for maintenance, etc., the following procedure is recommended.

- 1) Remove the covers ② and ③ of motor case ① and disconnect wiring cables from electric apparatuses of motor and solenoid valves, etc. and also, remove three piping of red, blue and black connected to the connector plate ④. (For piping, refer to the piping diagram of item 23.)
- 2) Loosen hexagon socket head cap screws ⑤ which fix the motor case ① and remove the motor case slowly with the motor case ① raised.

### 15-2. Countermeasures for waterproof

To prevent the motor from coolant penetration, O-rings are used to the mounting faces on the motor case ① and the connector plate ④, and also, liquid packing (1216 made by THREE BOND) are used on connection parts among the motor case ① and covers ②, ③.



When reassembling the motor case ① and connector plate ④, take extreme care so that the O-rings will not be damaged. If the O-rings are damaged, coolant may enter into the motor case.



When reassembling the covers, coat connection parts with liquid packing.



Connect the air hose correctly and take care so as not to bend it.

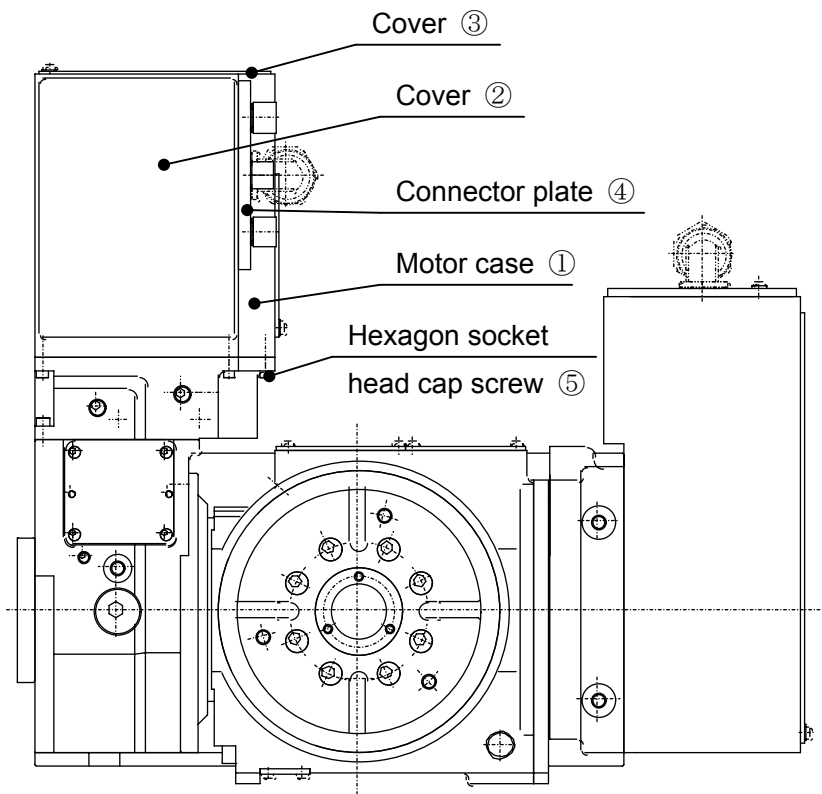

**Fig.14 (TT182)**

## 16. Motor

### 16-1. Tilting axis drive motor

#### 16-1-1. To remove motor

When replacing the motor, remove the motor according to the following procedure. (See Fig.15)

- 1) Drain lubrication oil from the lub. oil drain port of gear box. (See the outside view.)
- 2) Remove the motor case according to item 15-1.
- 3) Loosen hexagon bolt for stopper ⑧.
- 4) Remove hexagon socket head cap screws ⑤ which fix the motor ④.
- 5) Remove the motor ④ slowly, raising it.

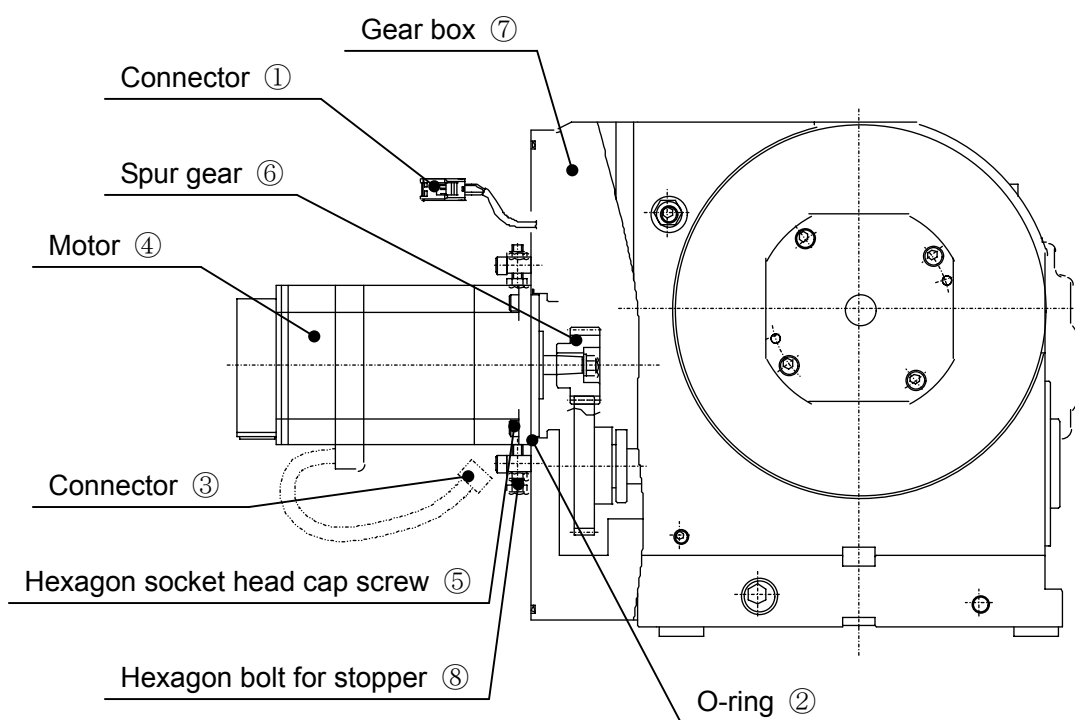

**Fig.15 (TT182)**

#### 16-1-2. To disassemble motor

- 1) Clean mounting faces (gear box ⑦ and motor ④) and O-ring grooves.
- 2) Mount the O-ring ② and mount the motor ④ by the reverse procedure as the above removing.
- 3) After mounting the motor, adjust the backlash of spur gears ⑥ according to item 12.



Mount the motor to the spur gear ⑥ carefully after cleaning so that the spur gears are not damaged.



When mounting the motor ④, take extreme care so that O-ring ② is not damaged because lubrication oil may enter into the motor case.



Connect the connector ① according to item 17-2. Connect the connector ③ securely so that the pin does not cause contact failure, and also cables are not bent or crushed.

## 16-2. Rotating axis drive motor

### 16-2-1. To remove drive motor

When replacing the motor, remove the motor according to the following procedure. (See Fig.16)

- 1) Drain lubrication oil from the rotating axis lub. oil drain port. (See the outline drawing.)
- 2) Remove the cover ⑦.
- 3) Loosen hexagon bolt for stopper ⑧.
- 4) Remove hexagon socket head cap screws ⑤ which fix the motor ④.
- 5) Remove the motor ④ slowly, raising it.

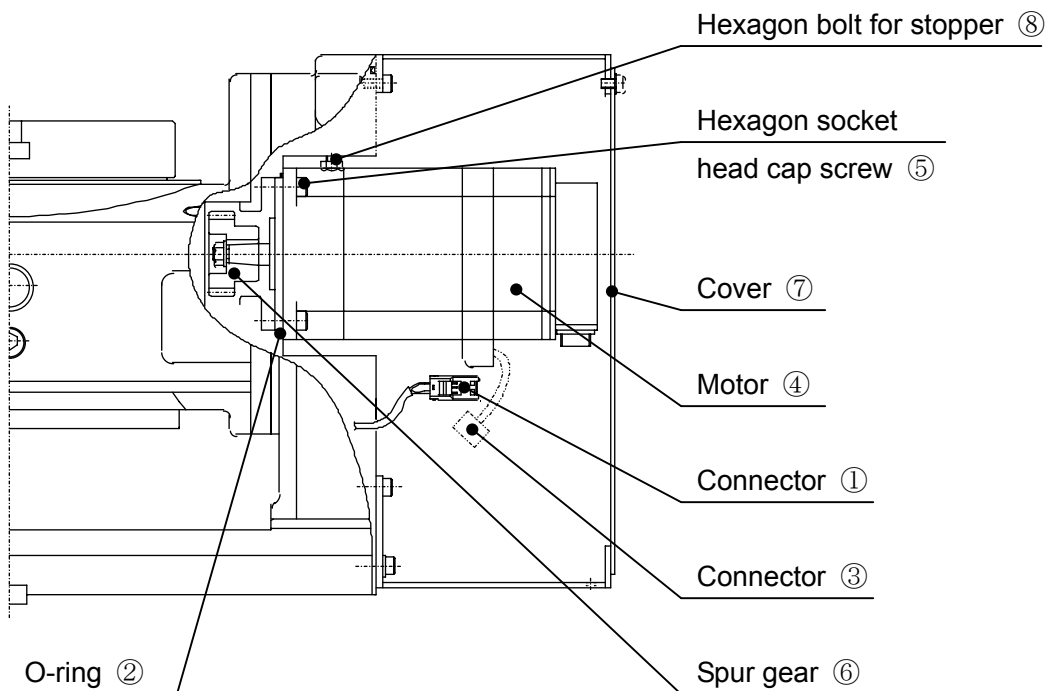

Fig.16

### 16-2-2. To mount drive motor

- 1) Clean mounting face (motor ④) and O-ring groove.
- 2) Mount the O-ring ② and mount the motor ④ by the reverse procedure as the above removing.
- 3) After mounting the motor, adjust the backlash of spur gears ⑥ according to item 12.



Mount the motor to the spur gear ⑥ carefully after cleaning so that the spur gears are not damaged.



When mounting the motor ④, take extreme care so that O-ring ② is not damaged because lubrication oil may enter into the motor case.



Connect the connector ① according to item 17-2. Connect the connector ③ securely so that the pin does not cause contact failure, and also cables are not bent or crushed.

### 16-3. To mount spur gears

The mounting method of spur gears varies by the motor shaft and flange diameter. The following procedure is recommended to mount the spur gears by three-method mainly used.

#### ○Taper shaft

- 1) Wipe up dust adhered on the taper shaft surface and inside of spur gears.
- 2) Attach the key to the shaft before mounting the spur gear.
- 3) Attach the washer and tighten the nut securely.

#### ○Straight shaft (with key)

- 1) Wipe up dust adhered on the straight shaft surface and inside of spur gears.
- 2) Attach the key to the shaft.
- 3) Fix the spur gear and washer securely.
- 4) Mount the spur gear with the washer to the shaft securely by using the bolt.

#### ○Straight shaft (locking element spec.)

- 1) Wipe up dust adhered on the straight shaft surface and inside of spur gears and coat them with oil or grease. However, do not use lubricate of silicon system or molybdenum



- system, or oil and grease including an extreme-pressure additive agent.
- 2) Insert the washer, locking element, spacer and spur gear in order.
  - 3) At this time, attach the locking element (Generic name for inner ring and outer ring) so as to pressurize the inner ring.
  - 4) Tighten bolts on each diagonal line equally in order so that the end face of spur gear and the flange end face of motor become parallel.
  - 5) Tighten the bolts until washers do not move in an axial direction. After that, adjust the mounting position of spur gear.
  - 6) Attach the dial gauge to the end face of spur gear and tighten bolts equally. Rotate the spur gears and also, tighten each bolt until the run out of dial gauge becomes 0.01mm or less.
  - 7) Check that the spur gears are fixed to the shaft securely.

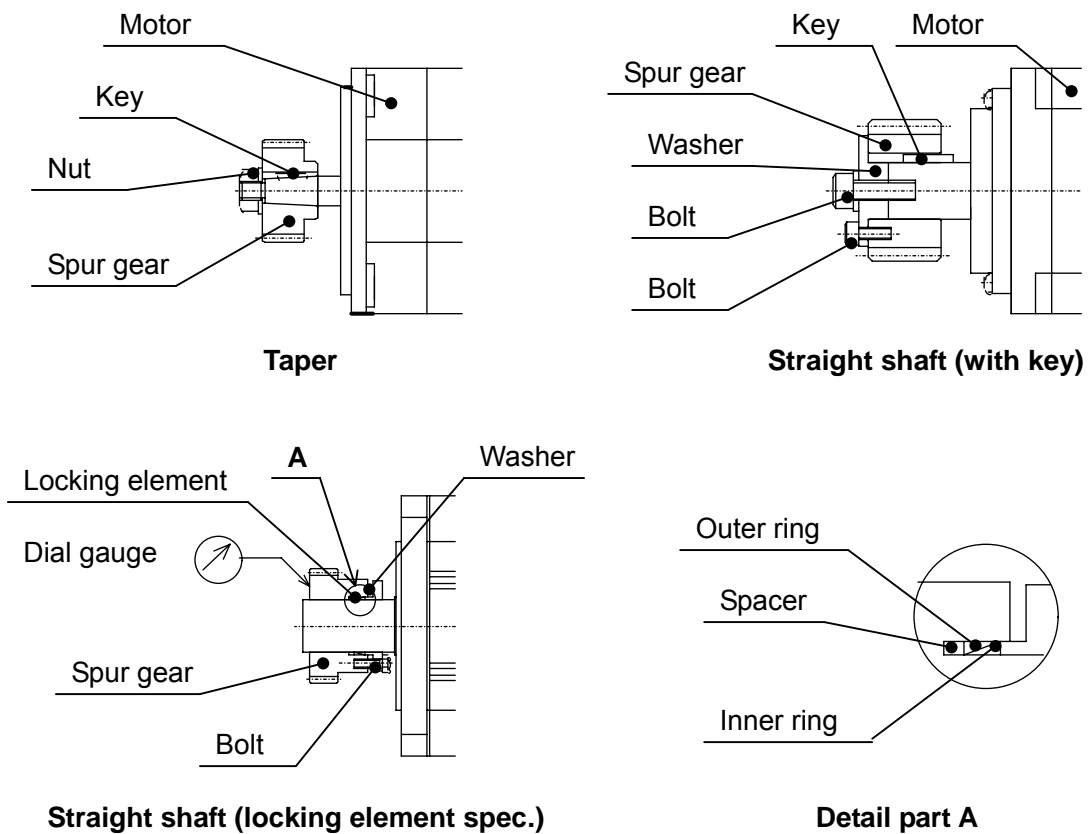

**Fig.17**

## 17. Connector

When removing connectors (made by MOLEX) such as proximity switches, etc., unavoidably in motor case removing, the following procedure is recommended.

### 17-1. To remove connector

- 1) Pushing the claw ③ of receptacle housing, remove the plug housing ① and receptacle housing ②.



Do not apply any load to cables.

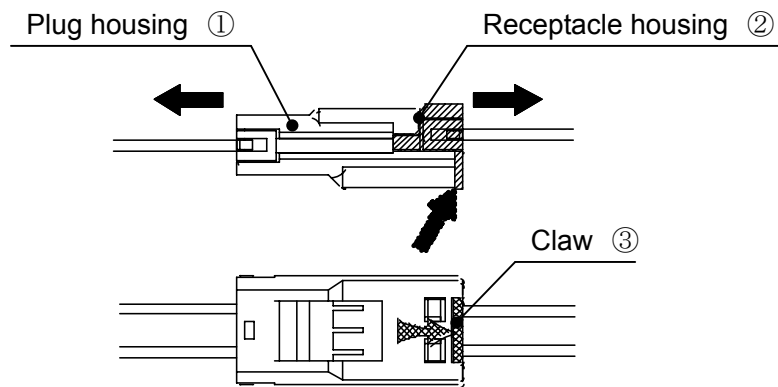

Fig.18

## 17-2. To mount connector

- 1) Mate the plug housing ① to the receptacle housing ② as shown in the following figure.
- 2) Insert the receptacle housing ② into the plug housing ① securely until a clicking noise occurs.
- 3) After mounting, pull the receptacle housing ② slightly and check that it does not draw out.



Check that connectors and cables are not damaged before connecting.



Connect cables so as not to be bent or crushed.



Do not apply any load to cables.

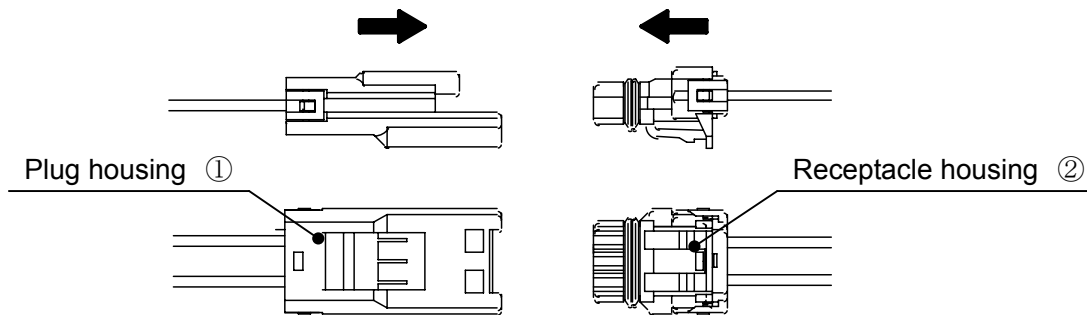
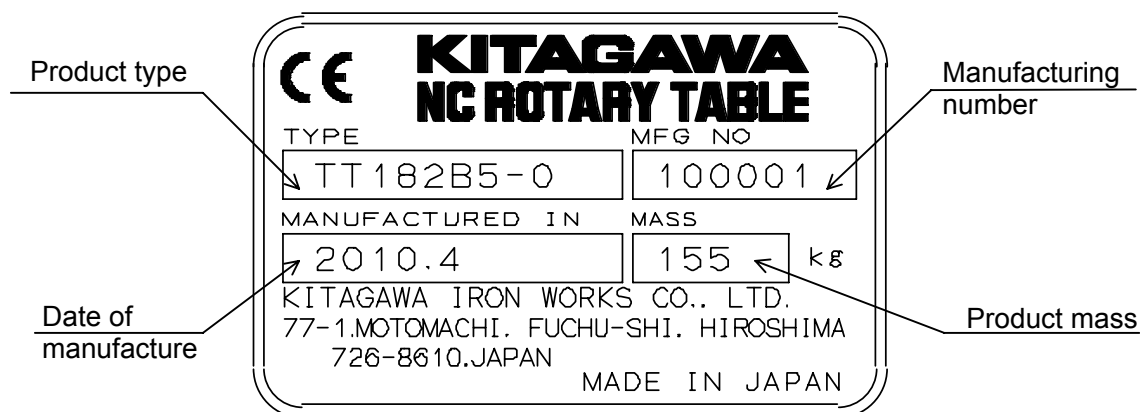

Fig.19

## 18. Troubleshooting

Check corresponding item given in this chapter to take corrective actions when the unit seems to be faulty. If the fault persists, please contact your sales agent (M/C maker) or us. When making an inquiry, let us know the product type and manufacturing number marked on the nameplate of the NC rotary table body.



### Nameplate

Symptom ①: Table does not rotate

Possible causes	Corrective actions
No cable connection between NC rotary table and control unit	Check the cable for connection, and connect it
Broken cable between NC rotary table and control unit	Check the cable for continuity, and replace it
Faulty clamp device	See "Symptom ⑤"
Decentered workpiece, overloaded fixture, and friction torque of steady rest and rotary joint make the load torque larger than the motor torque	Compare the specification of NC rotary table with the work condition to make improvement
Use of unit out of specified temperature range	Adjust ambient temperature within specified temperature range

Symptom ②: Table does not rotate but generates a noise

Possible causes	Corrective actions
Motor makes a howling sound to try to rotate →Seizure of gears due to lack or deterioration of lubricating oil	Stop the use of NC rotary table immediately. Please contact the sales agent.
Gears generate a noise → Faulty rotation due to damaged gears	Stop the use of NC rotary table immediately. Please contact the sales agent.
Unit generates a noise at startup and stops soon →Faulty rotation because foreign substances mix in the oil bath	Supply lubricating oil until foreign substances come out of the drain port.

Symptom ③: Table does not rotate smoothly but generates a noise

Possible causes	Corrective actions
Noise is generated repeatedly during rotation →Gears are damaged	Stop the use of NC rotary table immediately. Please contact the sales agent.
→Faulty rotation of gears because foreign substances mix in the oil bath	Open the lubricating oil drain port, and supply lubricating oil until foreign substances come out of the drain port.
Load due to overloading exceeds motor output	Compare the specification of NC rotary table with the work condition to make improvement
Lack or deterioration of lubricating oil blocks smooth rotation	Check oil level, viscosity and change interval of lubricating oil
Faulty clamp device	See "Symptom ⑤"
Inappropriate backlash amount	Adjust backlash amount to appropriate value

Symptom ④: Chattering occurs during cutting

Possible causes	Corrective actions
Inappropriate clamp condition of NC rotary table or fixture	Check the clamp condition, and correct it
Excess cutting force is applied during cutting	Adjust cutting condition to the specified condition to change the cutting force to appropriate value
Faulty clamp device	See "Symptom ⑤"
Faulty locking of worm spindle in the backlash adjustment	Readjust
Fault due to damaged NC rotary table or expired life of components	Stop the use of NC rotary table immediately. Please contact the sales agent.
Fault occurs only during continuous cutting →Lack or deterioration of lubricating oil blocks smooth rotation →Inappropriate backlash amount	Check oil level, viscosity and date of last change of lubricating oil Adjust backlash amount to appropriate value
Chips accumulate in rotary part of NC rotary table	Remove accumulated chips in daily inspection

Symptom ⑤: Table is not clamped or unclamped

Possible causes	Corrective actions
Faulty solenoid valve	Replace the solenoid valve
Faulty clamp/unclamp confirming device (pressure switch)	Check and replace the clamp/unclamp confirming device (pressure switch)
Damage or connection failure of working fluid pipe for clamp	Check the piping for connection, and replace
Supply pressure of working fluid for clamp is lower than specified value	Change to appropriate value according to the specification
Back pressure acts to the air pressure exhaust port of solenoid valve, as the air purge port in the motor case is blocked.	Remove the cause that blocks the air purge port.
Faulty clamp device	Stop the use of NC rotary table immediately. Please contact the sales agent.
Fault due to damaged NC rotary table or expired life of components	Stop the use of NC rotary table immediately. Please contact the sales agent.

Symptom ⑥: Index accuracy error

Possible causes	Corrective actions
The unit is overloaded during rotation	Compare NC rotary table specification with work condition to make improvement
Workpiece is dislocated due to low clamp torque	Compare NC rotary table specification with cutting condition to make improvement
Zero return position is dislocated due to faulty zero point shift adjustment	Check the zero point and zero point shift amount
Faulty zero point dog position adjustment	Adjust the zero point dog
Faulty zero return deceleration signal device	Check the zero return deceleration signal device and replace the proximity switch
Faulty clamp operation	See "Symptom ⑤"
Inappropriate backlash amount	Adjust the backlash
Inappropriate backlash compensation amount	Change the backlash compensation amount
Worm shaft locking failure in backlash adjustment	Readjust
Fault due to damaged NC rotary table or expired life of components	Stop the use of NC rotary table immediately. Please contact the sales agent.

## 19. Parts List

○ Main Body

MARK	NAME	TT182	TW182	Q'ty	Recital
01	Hexagon socket flange head screw plug with O-Ring	M20x1.5		1	Gosho
02	Hexagon socket headless tapered pipe plug	Rc3/8		2	
03	Hexagon socket headless tapered pipe plug	Rc3/8	—	2	
	Hexagon socket headless tapered pipe plug	—	Rc1/2		
04	Hexagon socket headless tapered pipe plug	Rc1/2		1	
05	Machine screw	M5x8		6	
06	Machine screw	M5x20		3	
07	Seal washer	5		5	
08	Cover (1)			1	
09	O-Ring	S85		1	
10	Hexagon socket head cap screw	M6x20		4	
11	Hexagon socket headless set screw (Flat Point)	M8x20		8	
12	Cover (2)			1	
13	O-Ring	G40		1	
14	Hexagon socket headless set screw	M6x6		2	
15	Plug	MPG14		1	Pisco
16	Hexagon socket headless set screw (Flat Point)	M8x8		3	
17	Hexagon socket headless set screw (Flat Point)	M8x12		1	
18	Steel ball	6.3		3	
19	Steel ball	4.7		1	
20	Cover (3)			1	(Booster)
21	Hexagon socket head cap screw (Special low head)	SSH-M5×10		4	(Booster)
22	O-Ring	G70		1	(Booster)
23	Different diameter elbow	NR-202	—	2	Musashi (Hydraulic)
24	Hexagon socket headless tapered pipe plug	—	RC1/4	2	(Hydraulic)
25	Cover (4)	—		1	
26	O-Ring	—		GS270	1
27	Machine screw	—		M6x12	6

TT182

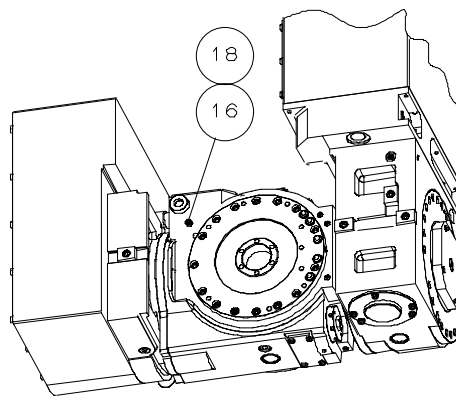
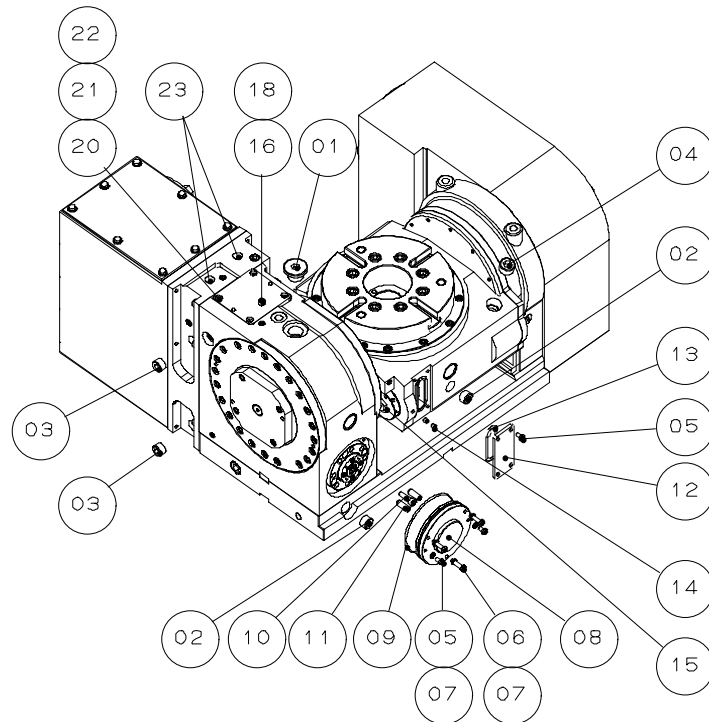

TW182

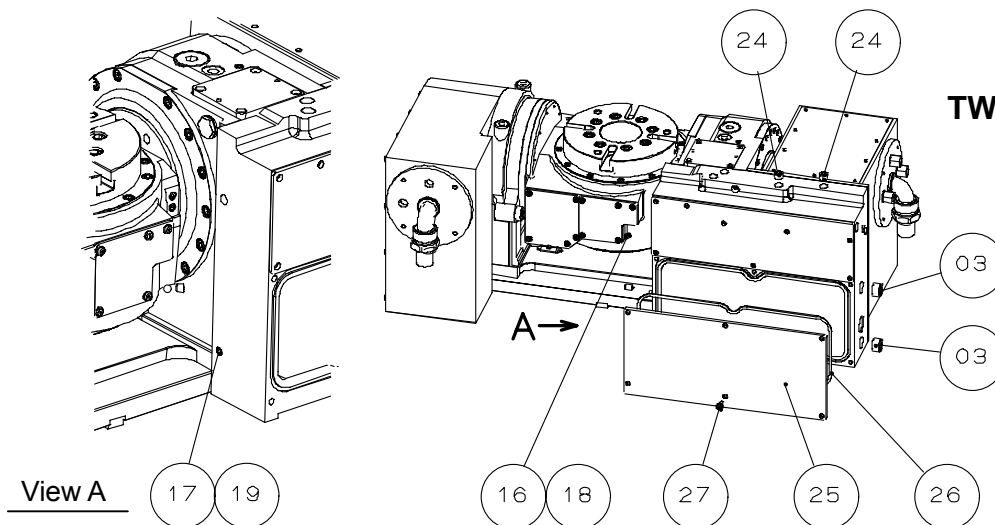



○ Motor Case(For M Signal)

MARK	NAME	TT182	TW182	Q'ty	Recital
31	Machine screw	M5x8 (38)	M5x8 (36)	(*)	(Booster)
			M5x8 (40)		(Hydraulic)
32	Seal washer	5 (49)	5 (47)	(*)	(Booster)
		5 (51)	5 (53)		(Hydraulic)
33	Cover (1)			1	
34	Cover (2)			1	
35	Cover (3)		—	1	
36	Bulkhead connector	KQE06-02		1	SMC (Booster)
37	Bulkhead connector	KQ2E06-03		2	SMC (Booster)
		KQE06-01 (1)	KQE06-01 (2)	(*)	SMC (Hydraulic)
38	Seal washer	14S1		3	(Booster)
		14S1 (1)	14S1 (2)	(*)	(Hydraulic)
39	Machine screw	M5x16	M5x16	4	(Booster)
			M5x12		(Hydraulic)
40	Connector plate (1)			1	
41	O-Ring	S130		2	
42	Hexagon socket head cap screw	M5x16	M6x16	6	
43	Washer	5	—	3	
44	Motor case (1)			1	
45	O-Ring	GS250	GS270	1	
46	Cover (4)			1	
47	Machine screw	M5x12		4	
48	Connector plate (2)			1	
49	Hexagon socket head cap screw	M5x12		11	
50	Motor case (2)			1	
51	O-Ring	GS230		1	
52	O-Ring	P22		1	
53	Hexagon socket head cap screw (Special low head)	SSH-M5x8		2	(Hydraulic)

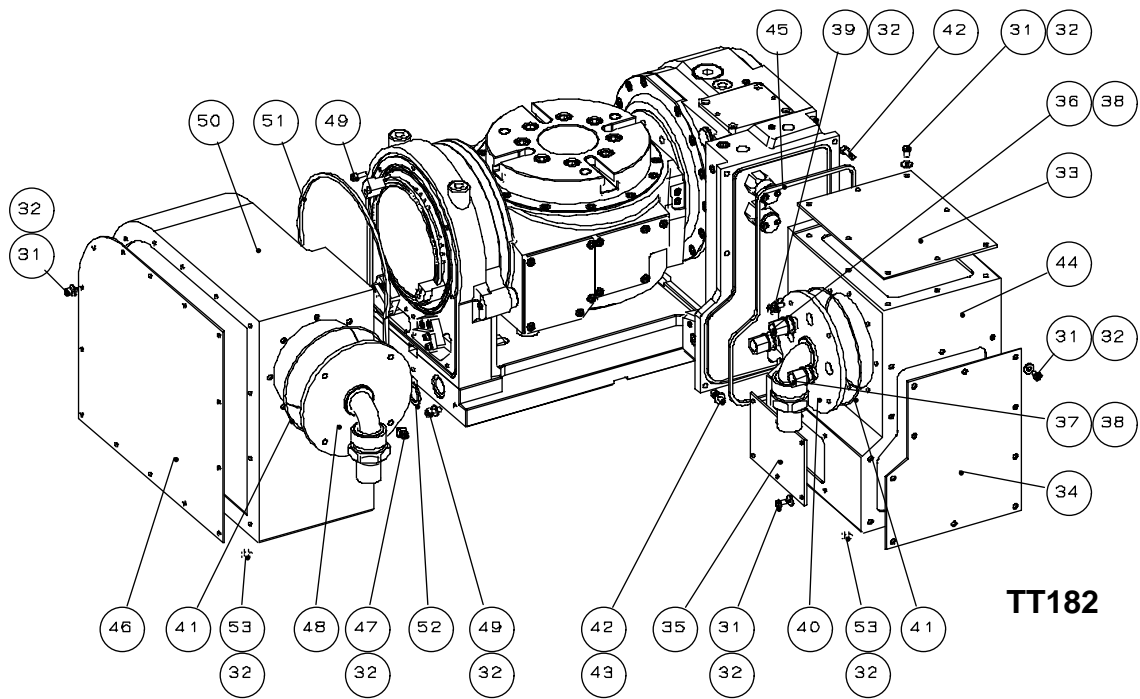

**TT182**

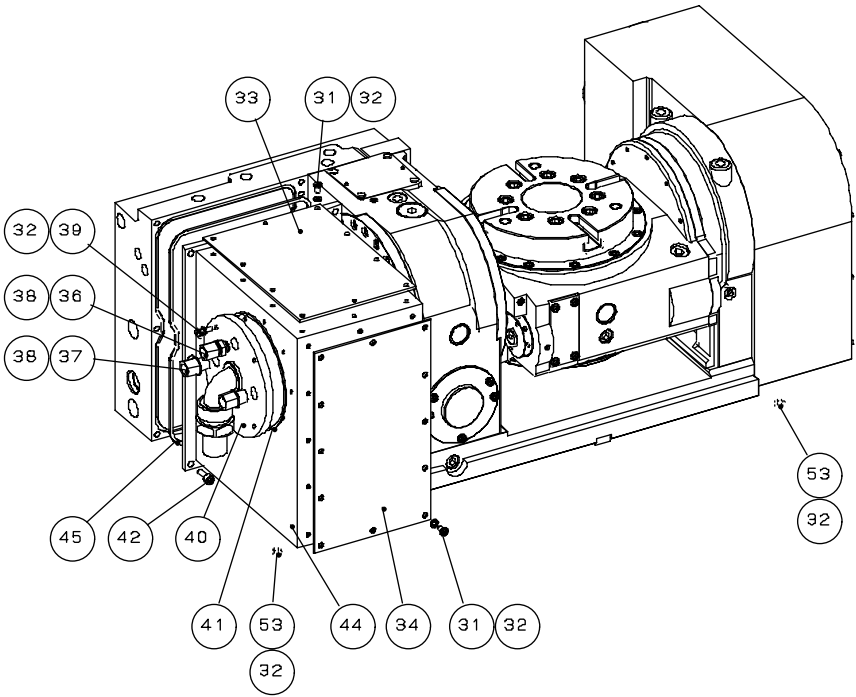

**TW182**

When the specification is 4th and 5th axes, the motor case and the cable are different from the above figure.

For detailed models, refer to attached outside view.

○ Clamp Detection Device

MARK	NAME	TT182	TW182	Q'ty	Recital
61	Solenoid valve	SYJ7120-5GS-01-F-Q		2	SMC (Booster)
62	Machine screw	M4x6		4	(Booster)
63	Plug silencer	PSA103		2	TAIYO (Booster)
64	Pressure switch for clamp detection	176 112 200		2	SKF
65	Pressure switch for unclamp detection	176 120 400		2	SKF
66	Cover	—		1	
67	Machine screw	—	M6x12	8	
68	O-Ring	—	GS240	1	

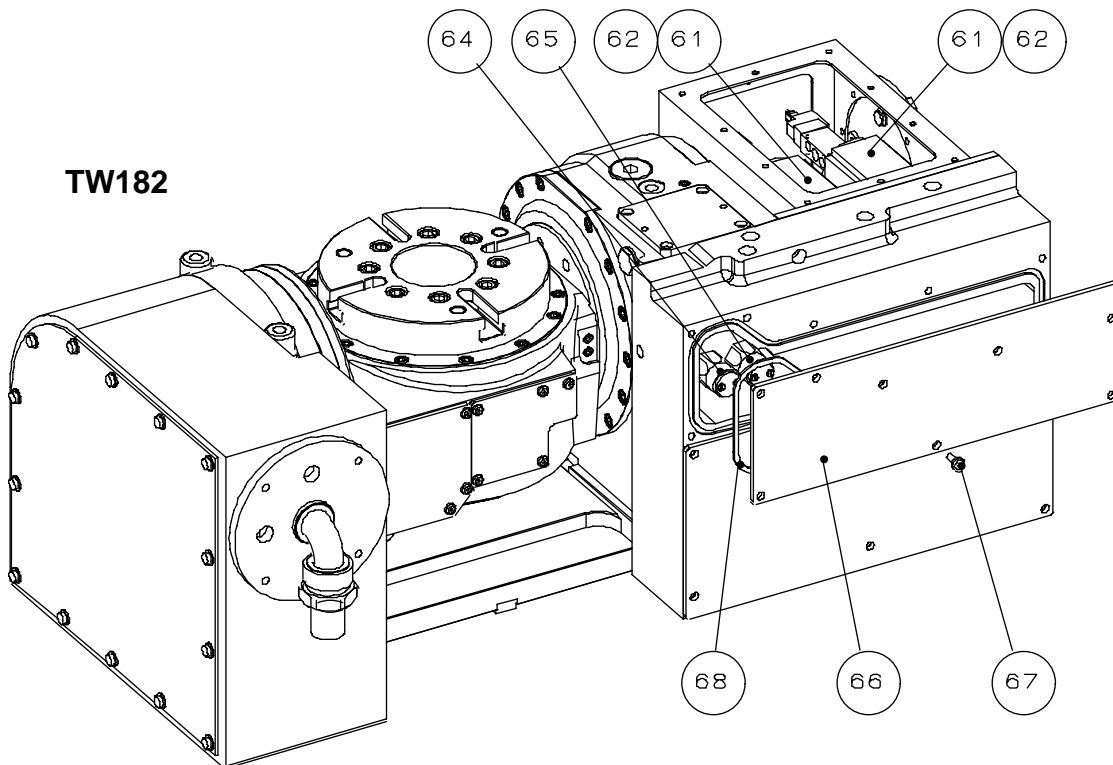
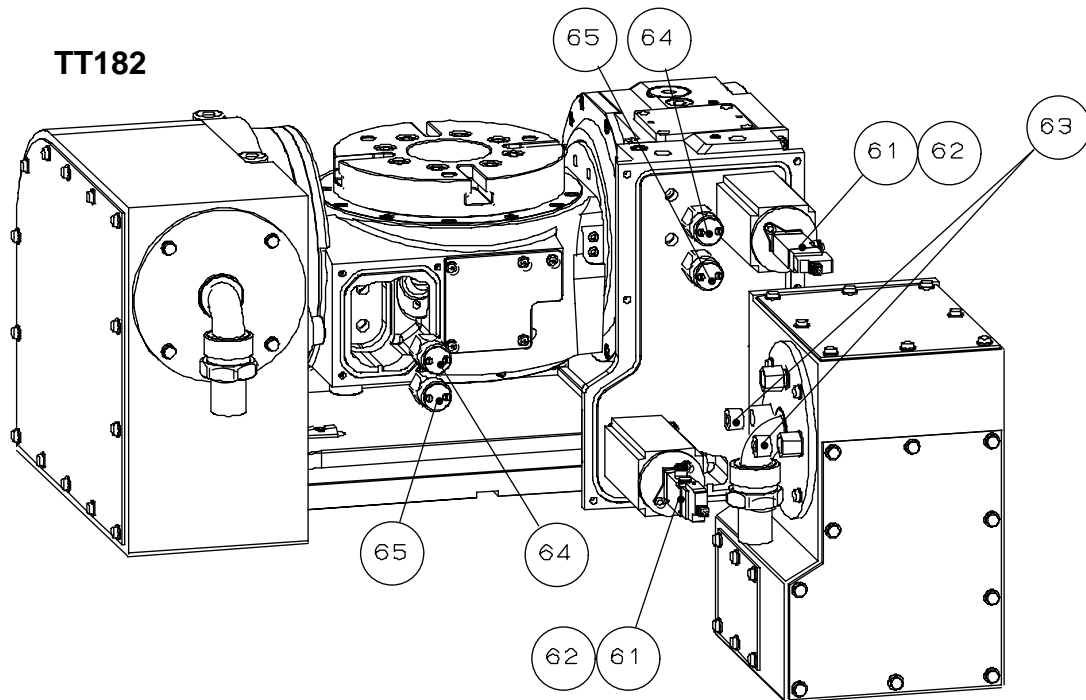

When the specification is different, the model and the installation position of the solenoid valve and the pressure switch are different from the above figure.

For detailed models, refer to attached wiring diagram.

○ Built-in ZRN (Zero Return) Device

MARK	NAME	TT182 TW182	Q'ty	Recital
71	Machine screw	M5x8	5	
72	Cover		1	
73	O-Ring	G85	1	
74	O-Ring	P16	1	
75	Machine screw	M6x8	1	
76	Washer	6	1	
77	Holder for Proximity switch		1	
78	Seal washer	DT-1-12	1	Mitsubishi Cable
79	Proximity switch	FL7M-3K6H	2	Yamatake

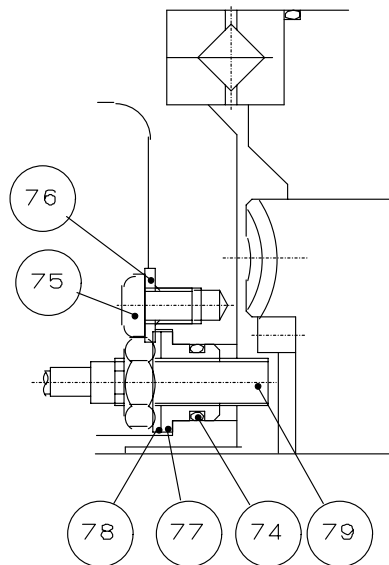
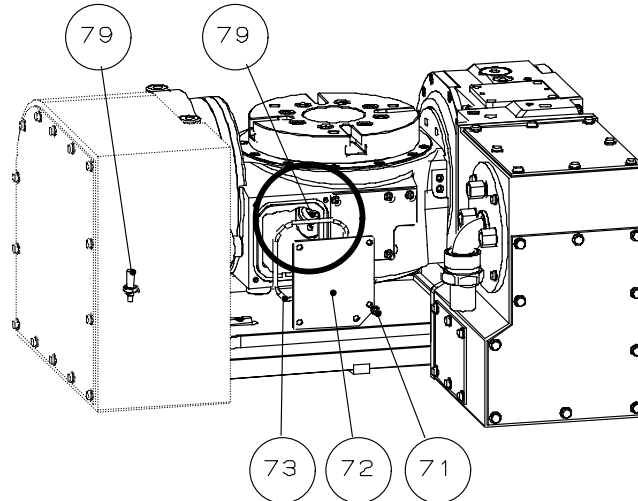

No proximity switch is provided for the M signal type.

○ Accessory

MARK	NAME	TT182 TW182	Q'ty	Recital
91	Eye bolt	M10	3	
92	Clamp		4	
93	Hexagon head bolt	M16x65	4	Strength Dimension: 8.8
94	Washer	16	4	
95	T-slot nut	1816	4	

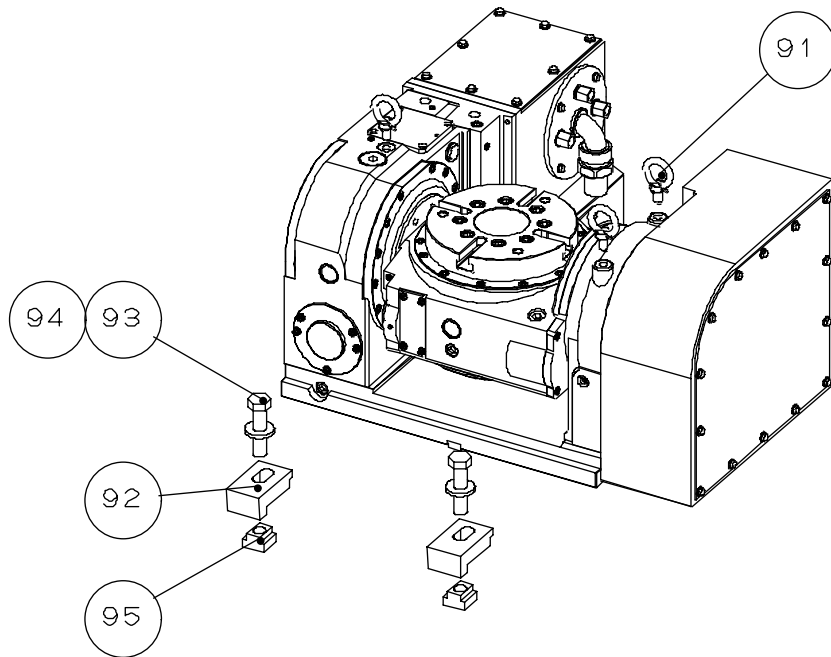

When the specification is different, the clamping parts and guide block are different from the above figure. For detailed models, refer to attached outside view.

## 20. Storage

### NOTICE

When storing NC rotary table after removing it from the machine tool, place it on the stable wooden base for maintaining accuracy after removing chips or coolant, etc. Coat the table with rust prevention oil and case or lap it with the wooden cover or vinyl cover, etc. When using the wooden base and box, avoid the wooden base and the green wood. Since the green wood is not chemically neutral, use the wood moistened with paraffin.

## 21. Disposal of NC Rotary Table

Dispose of this unit in accordance with the laws and regulations of your country.

You may suffer punishment if you disposed of this unit without following the laws and regulations.

## 22. Reference Data

### 22-1. Conversion of arc length and angle

#### NOTICE

“What is the linear length at the table circumference with 20 seconds cumulative indexing accuracy ?”

“What is the angle with a cumulative pitch error of 0.01mm ?”

To answer these questions, use the following formula representing the relationship between the angle and linear length at the table circumference.

D: Diameter of Workpiece (mm)

$\alpha$  : Angle (seconds)

L: Linear length at the table circumference (mm)

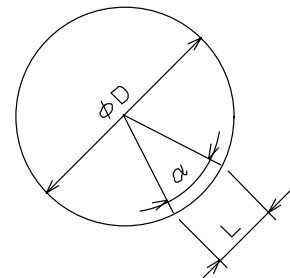

$$\frac{L}{\pi \times D} = \frac{\alpha}{360^\circ \times 60' \times 60''} \dots\dots\dots (1)$$

$$\alpha = \frac{360 \times 60 \times 60 \times L}{\pi \times D} = \frac{4.125 \times L \times 10^5}{D} \dots\dots\dots (2)$$

$$L = \frac{\alpha \times \pi \times D}{360 \times 60 \times 60} = 2.424 \times 10^{-6} \times \alpha \times D \dots\dots\dots (3)$$

(Examples)

Assuming the diameter of the workpiece is 100mm, and by using formula (2), the cumulative indexing accuracy of 20 seconds as linear length at table circumference will be:

$$L = 2.424 \times 20 \times 100 \times 10^{-6} = 0.004848mm$$

Therefore, the length is approximately 0.0048mm.

And converting the cumulative pitch error of 0.01mm to an angle, use formula (3):

$$\alpha = \frac{4.125 \times 0.01 \times 10^5}{100} = 41.25''$$

Therefore, the angle is approximately 41 seconds.

Thus, by using the formula (2) and (3), the indexing precision and pitch error can be converted in terms of linear length and angle.



## 22-2. Coordinate calculation of table center for tilting angle

When the coordinate of table center as the tilting axis is  $0^\circ$  (horizontal) is regarded as  $X = 0$ ,  $Z = 0$ . the calculation formula finding the coordinate of table center when tilting axis is tilted  $\theta^\circ$  is shown as follows:

$$X = F \cos \theta - E \sin \theta - F$$

$$Z = E \cos \theta + F \sin \theta - E$$

<Example>

In case of  $E=70$ ,  $F = 0$ .

$$X = -70 \sin \theta$$

$$Z = 70 \cos \theta - 70$$

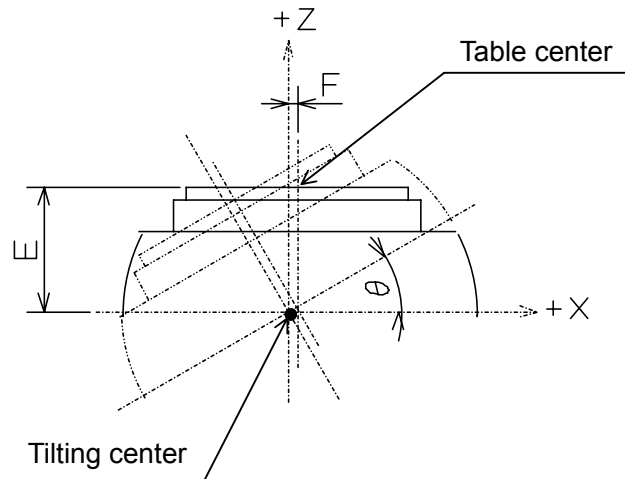

## 22-3. Workpiece interference area

Since the following shows standard specifications, take care in case of special specifications.

Interference with the clamp device is not considered.

Tilting range may be reduced due to fit the Jig or Chuck onto Face plate.

(Refer to the back of the Instruction Manual drawing and the outside view.)

Set a soft limit by the parameter to prevent interference at the customer.

<TT182, TW182>

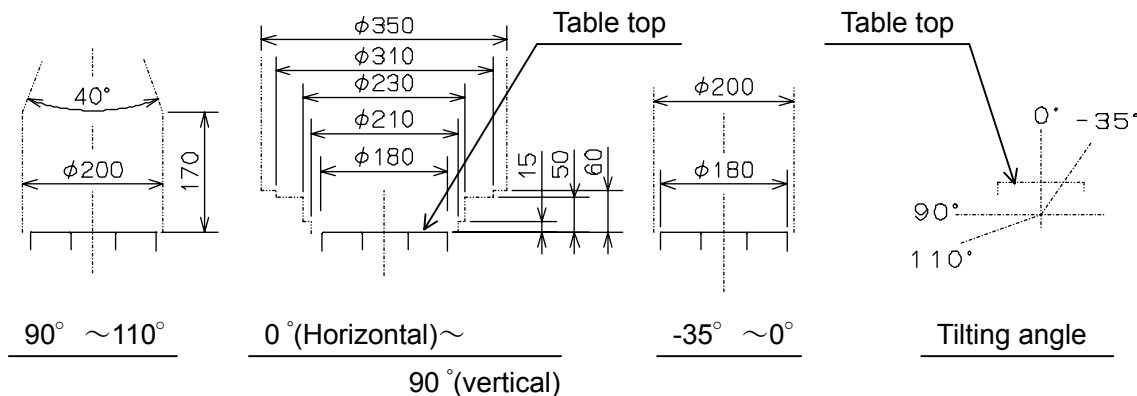

## 23. Piping Diagram on Air Hydraulic System

When removing the piping unavoidably to remove the motor case, refer to the following outside view and circuit diagram. For detailed models, refer to attached outside view.

### 23-1. Outside view of connection piping system

#### 23-1-1. Outside view of piping system for rotating axis

(In case of TT182)

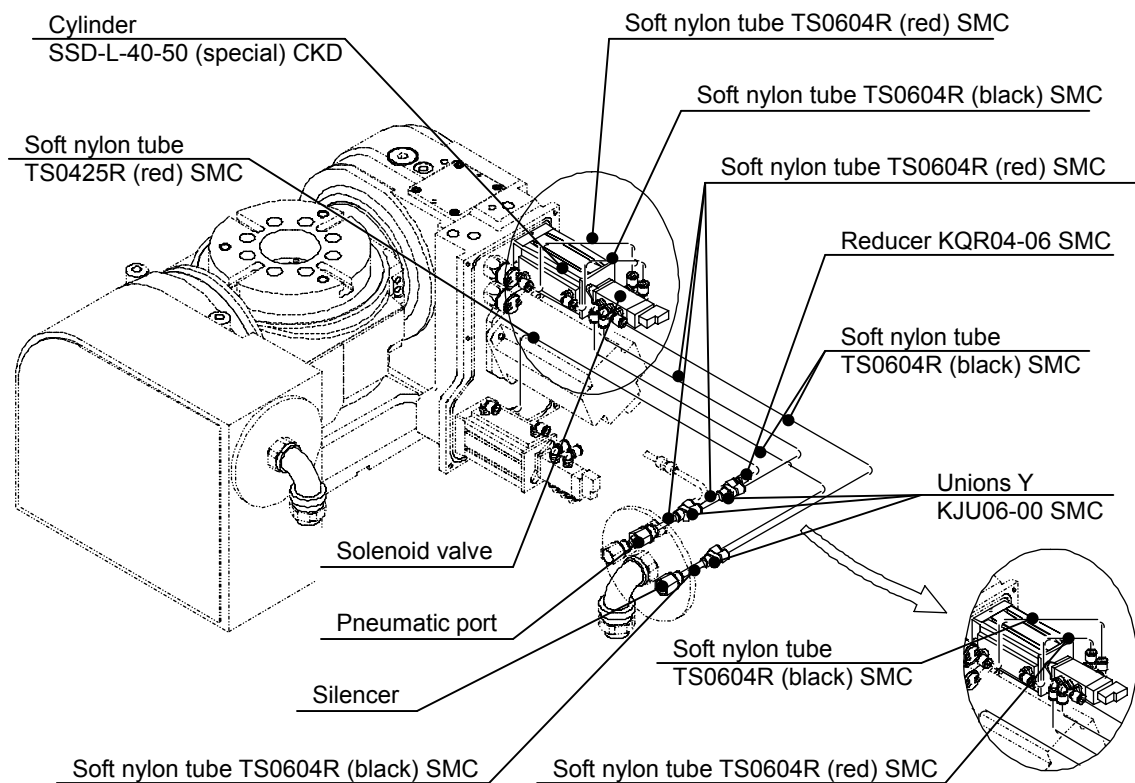

Excitation Unclamp Spec.

Excitation Clamp Spec.

(In case of TW182)

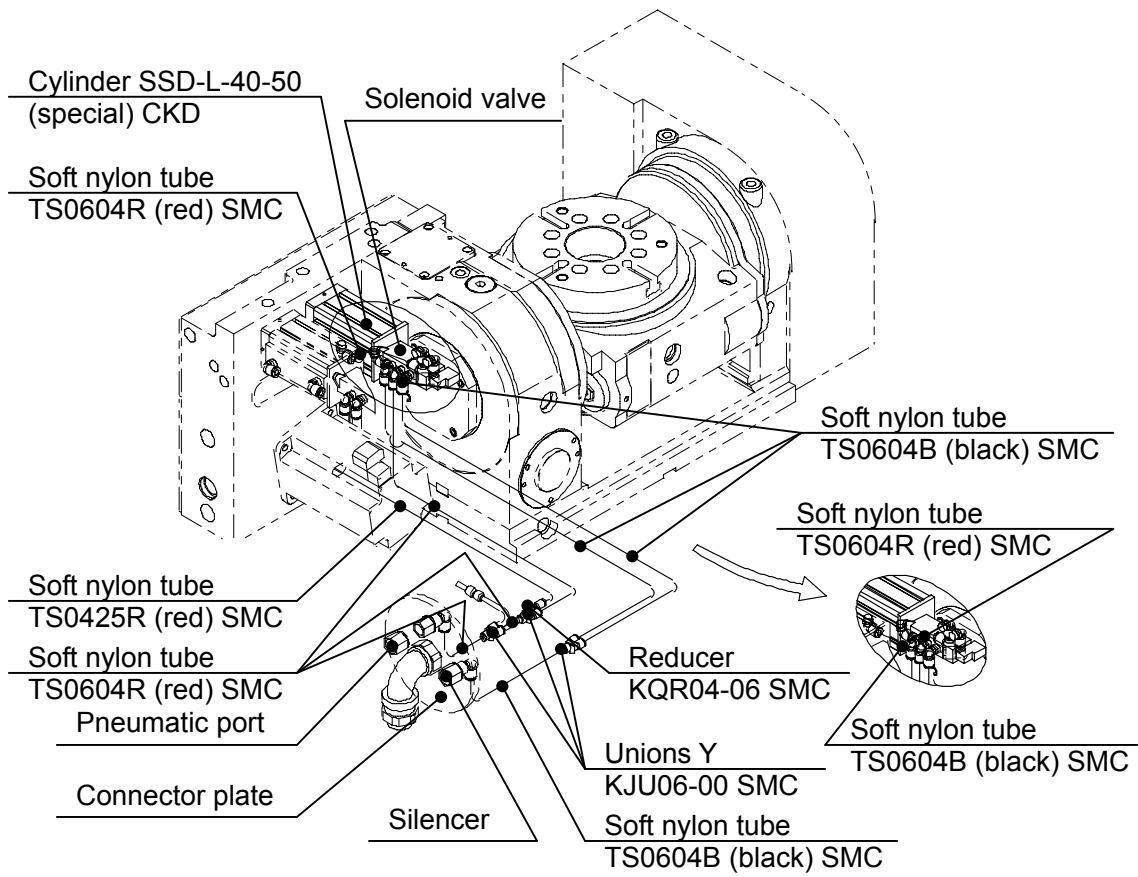

Excitation Unclamp Spec.

Excitation Clamp Spec.

**23-1-2. Outside view of piping system for tilting axis**

(In case of TT182)

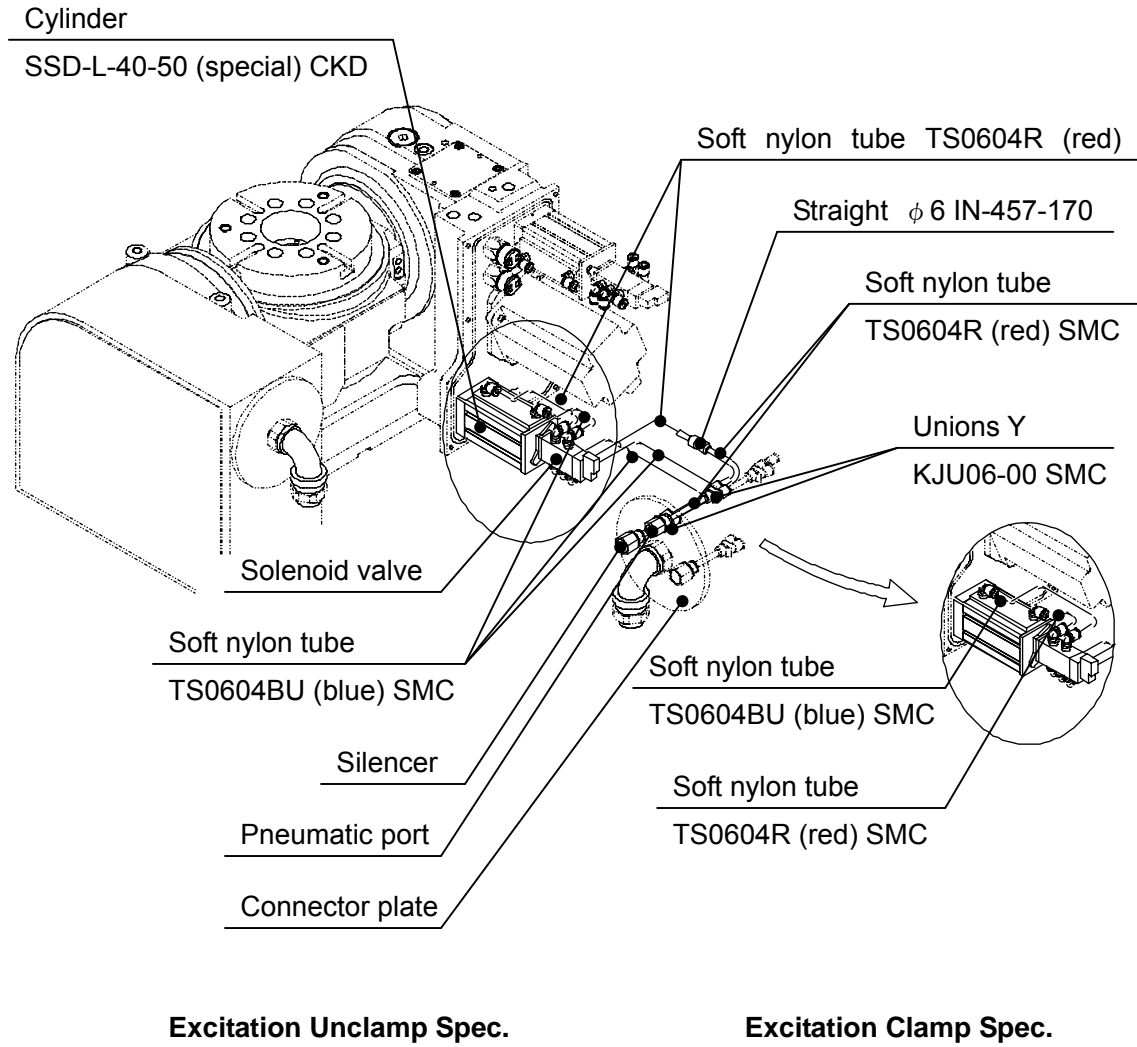

(In case of TW182)

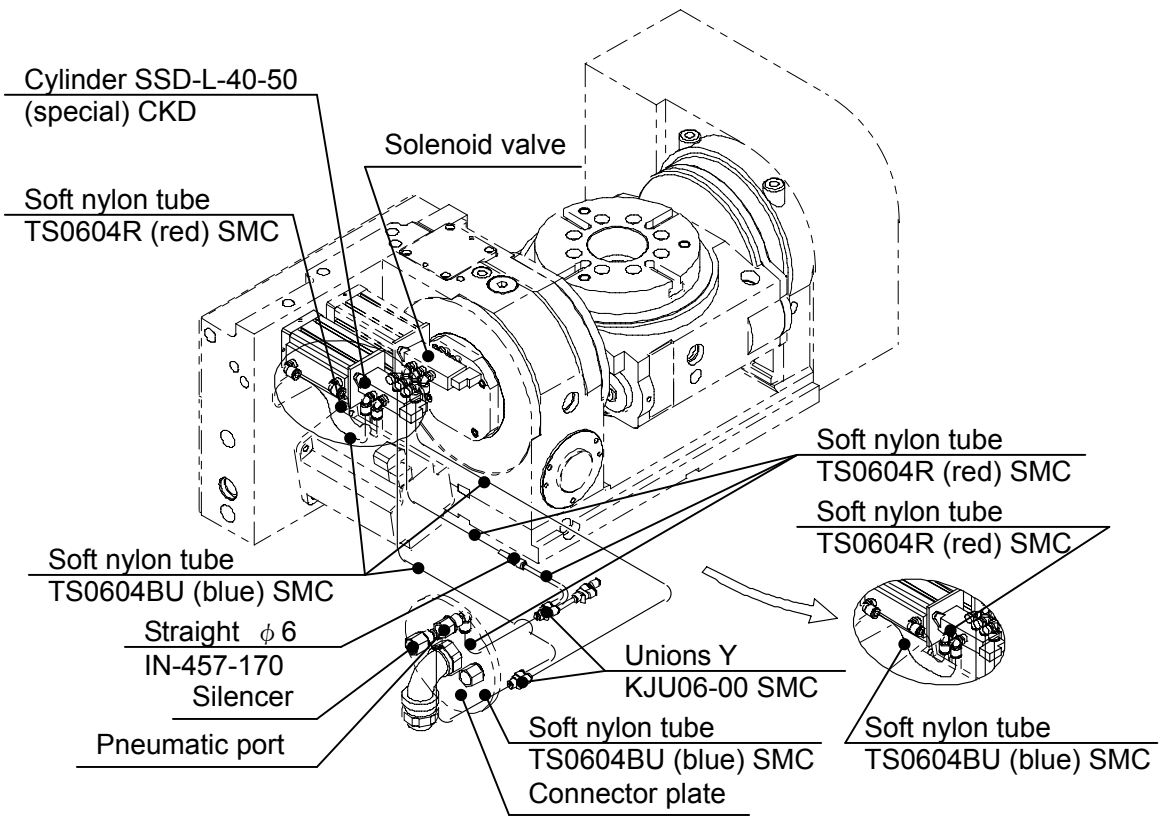

Excitation Unclamp Spec.

Excitation Clamp Spec.

**23-2. Pneumatic/hydraulic circuit diagram**

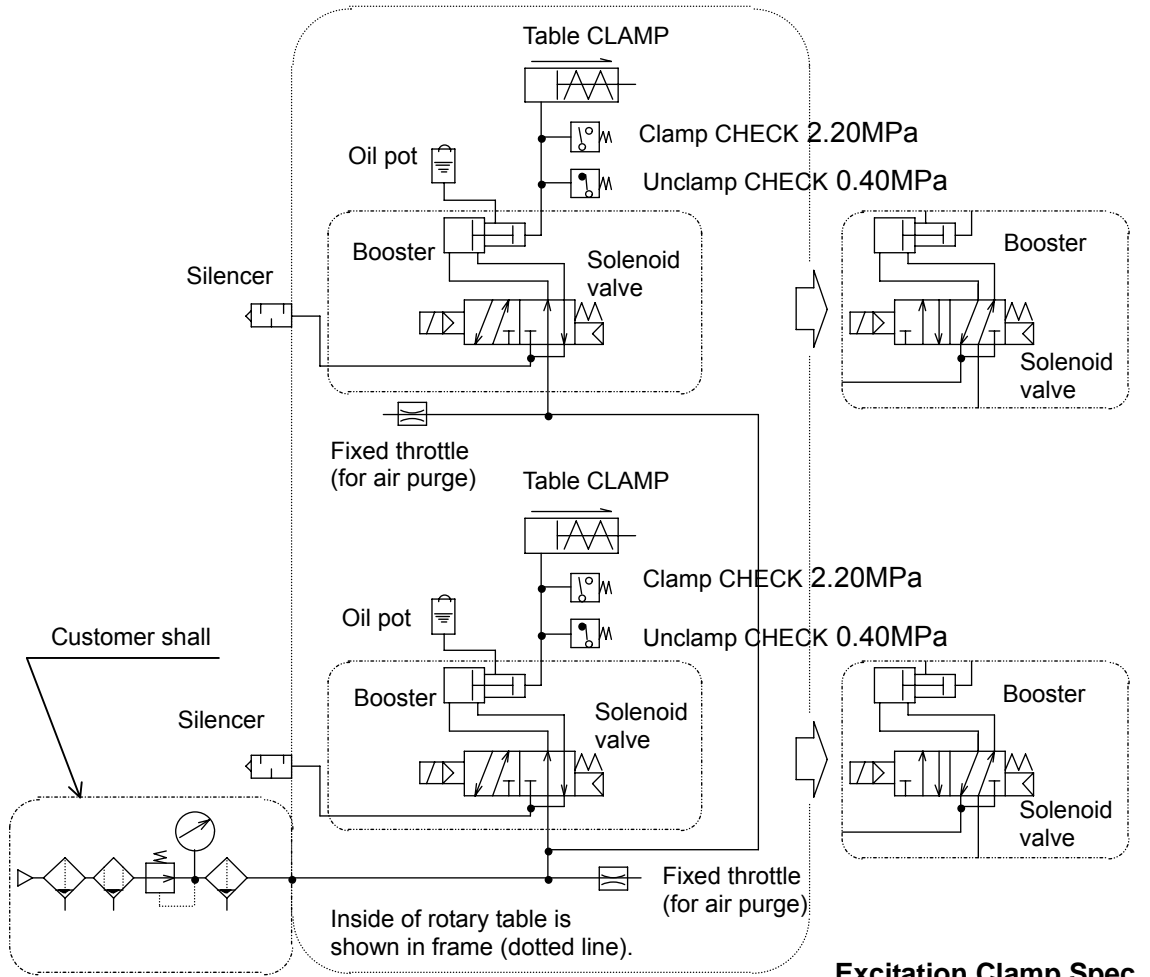

Air combination  
(Air filter + Mist separator +  
Regulator) + Drain catcher

Excitation Unclamp Spec.

## 24. Piping Diagram on Hydraulic System

### 24-1. Outside view of connecting piping system

(In case of TT182)

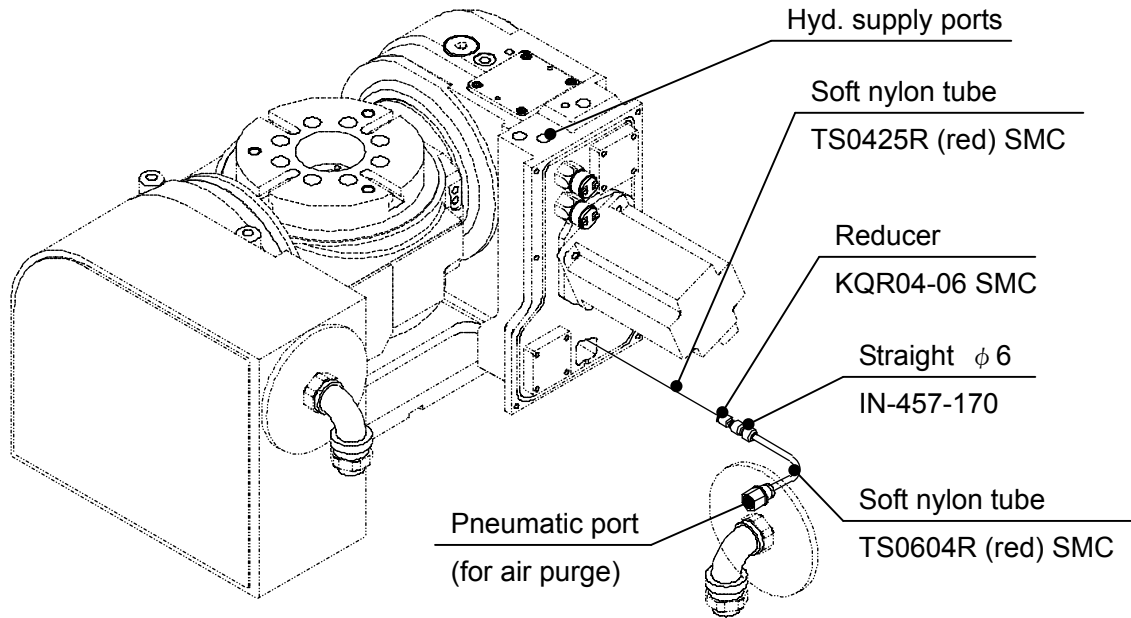

(In case of TW182)

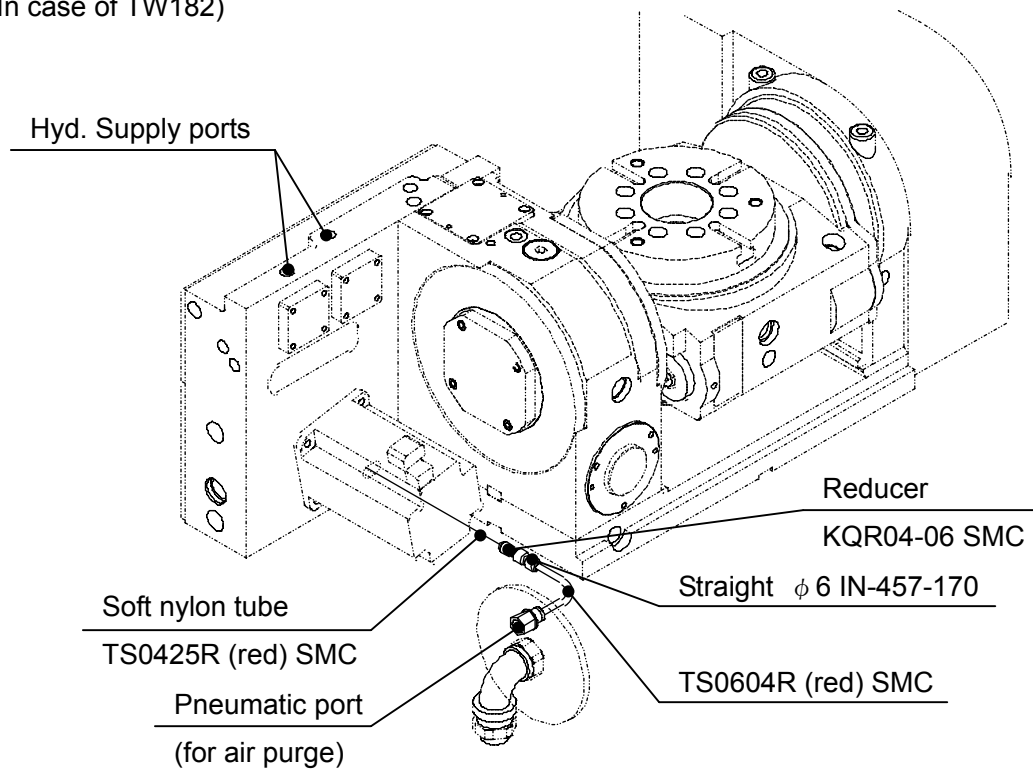

## 24-2. Hydraulic circuit diagram

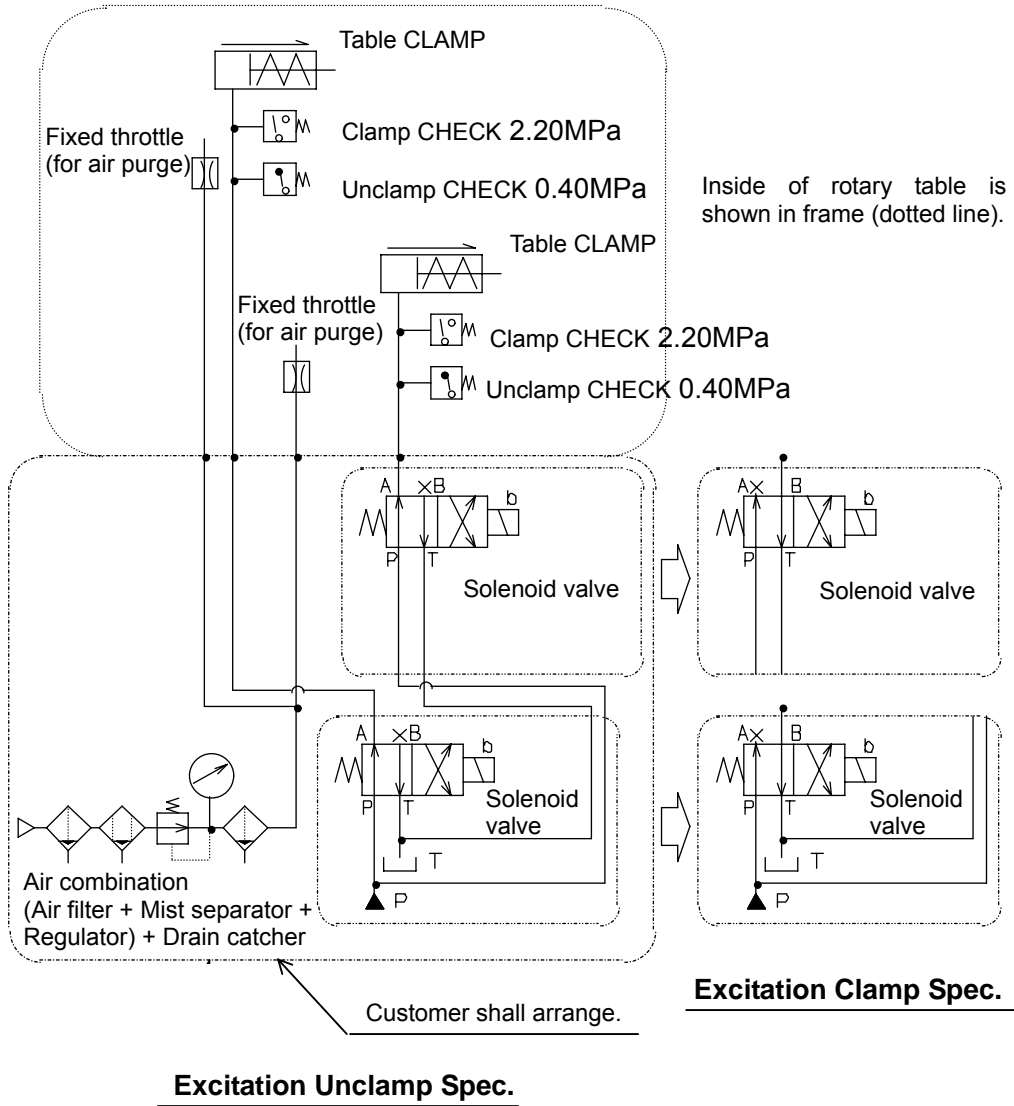



## 25. Outside view of Air Hydraulic Part

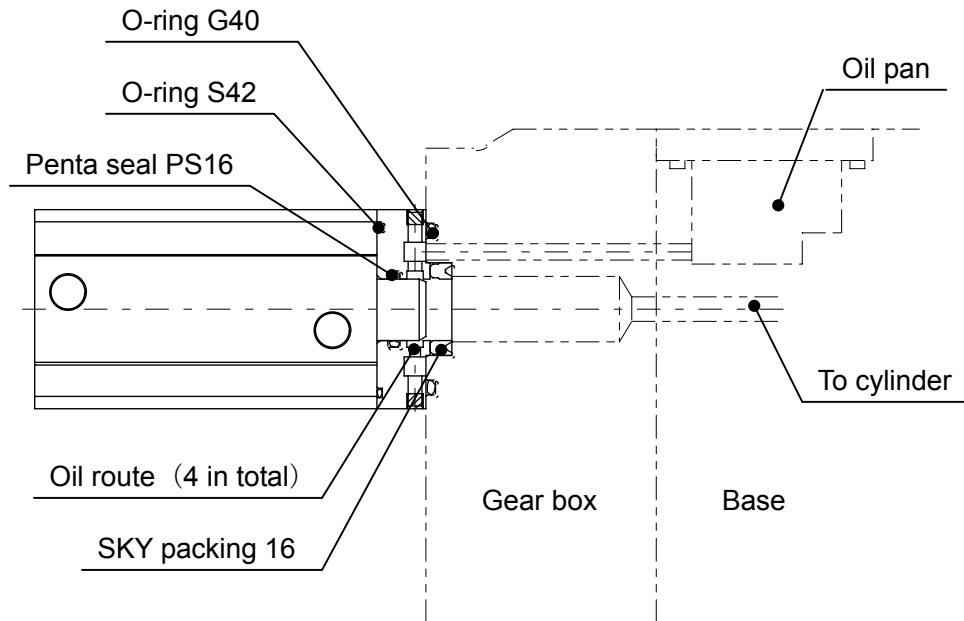

### Pneumatic Specifications

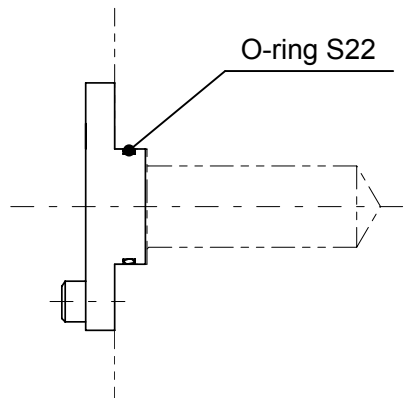

### Hydraulic Specification



CUSTOMER		
MF. NO.	D A T E	REASON OF REVISION
1	07.01.09	ADJUSTMENT(Δ1 PLACE)

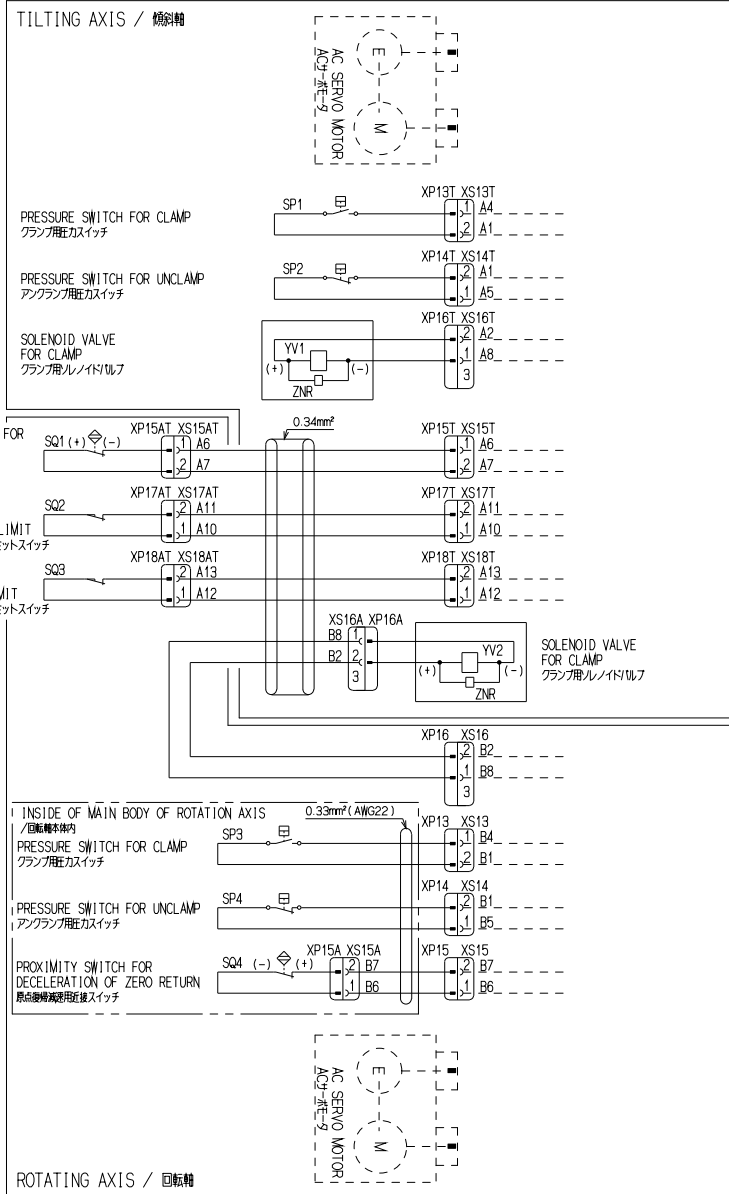

(OTスイッチ / OT SWITCH) ※ □  
(ソレノイド電圧 / SOL VOLTAGE) ※ □

MARK 記号	NAME 品名	MAKER メーカー	TYPE 型式	Q'ty 数量	REMARKS 備考
SP1, SP3	PRESSURE SWITCH 圧力スイッチ	SKF	176 112 200	2	2.2MPa 1a
SP2, SP4	PRESSURE SWITCH 圧力スイッチ	SKF	176 120 400	2	0.4MPa 1b
SQ1	PROXIMITY SWITCH 近接スイッチ	Azbil	FL7M-2K6H	1	DC10~30V
SQ2, SQ3	LIMIT SWITCH リミットスイッチ	Azbil	LJM-D2502L1	2	△
SQ4	PROXIMITY SWITCH 近接スイッチ	Azbil	FL7M-3K6H	1	DC10~30V
YV1, YV2	SOLENOID VALVE ソレノイドバルブ	SMC	SVJ7120-5GS-01-F-Q	2	DC24V
XP13, XP13T	PLUG HOUSING プラグハウジング	MOLEX	52116-0240	2	
XP14, XP14T	PLUG HOUSING プラグハウジング	MOLEX	52116-0241	2	
XP15, XP15A XP15T, XP15AT	PLUG HOUSING プラグハウジング	MOLEX	52116-0242	8	
XP17T, XP17AT XP18T, XP18AT	PLUG HOUSING プラグハウジング	MOLEX	52116-0341	3	
XS13, XS13T	RECE HOUSING レセハウジング	MOLEX	52117-0240	2	
XS14, XS14T	RECE HOUSING レセハウジング	MOLEX	52117-0241	2	
XS15, XS15A XS15T, XS15AT	RECE HOUSING レセハウジング	MOLEX	52117-0242	8	
XS17T, XS17AT XS18T, XS18AT	RECE HOUSING レセハウジング	MOLEX	52117-0341	3	

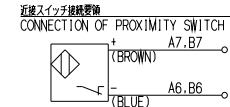

近接スイッチ仕様  
SPECIFICATIONS

使用電圧範囲	OPERATING VOLTAGE RANGE	DC10~30V
動作電流	SWITCHING CURRENT	3~100 mA
漏れ電流	LEAKAGE CURRENT	max. 0.55 mA
動作電圧降下範囲	RESIDUAL VOLTAGE	max. 3.0 V
出力接点	OUTPUT CONTACT	NC

ソレノイドバルブ仕様  
SOLENOID VALVE SPECIFICATIONS

	YV1, YV2
定格電源電圧 RATED SUPPLY VOLTAGE	DC24V
消費電力 POWER CONSUMPTION	0.35W

CAREER	SCALE	TYPE	TT182BE-01	WEIGHT	k.g
MANAGER	CHIEF	DRAWN BY T. OGASAWARA	NCテーブル NC ROTARY TABLE		
		DATE 06.04.24	3RD ANGLE	NAME タンキシヨウ WIRING DIAGRAM	
KITAGAWA IRON WORKS CO., LTD.			DRW NO.	61E253270	△1

1

2

3

4

5

6

CUSTOMER		
MOD. NO.	DATE	REASON OF REVISION
1	12.07.26	ADJUSTMENT

A

A

B

B

C

C

D

D

油圧仕様のみ  
Only the HYDRAULIC  
傾斜軸油圧供給口  
HYDRAULIC PORT  
FOR ROTATING AXIS  
シールU  
(61E456989)

油圧仕様のみ  
Only the HYDRAULIC  
傾斜軸油圧供給口  
HYDRAULIC PORT FOR TILTING AXIS  
シールV  
(61E456990)

空油圧仕様のみ  
Only the BOOSTER  
TT182, TW182を除く  
Excluding TT182 and TW182  
Rc1/4  
回転軸クランプ用空気供給口  
PNEUMATIC PORT  
FOR ROTATING AXIS  
TABLE CLAMP  
シールA  
(61E448856)

空油圧仕様のみ  
Only the BOOSTER  
TT182, TW182を除く  
Excluding TT182 and TW182  
Rc1/4  
傾斜軸クランプ用空気供給口  
PNEUMATIC PORT  
FOR TILTING AXIS  
TABLE CLAMP  
シールA  
(61E448856)

M8 クランプ用エア抜き  
AIR RELIEF PLUG  
FOR CLAMP  
シールE  
(61E438619)

PLメイン  
PL NAME PLATE  
(61E433880)

M20 傾斜軸潤滑油供給口  
LUBRICATION PORT  
FOR TILTING AXIS  
シールB  
(61E430246)

シール テドウオクリ  
DIRECTION OF  
MANUAL OPERATION  
(61E446547)

Rc1/2 回転軸潤滑油供給口  
LUBRICATION PORT  
FOR ROTATING AXIS  
シールB  
(61E430246)

M8 クランプ用エア抜き  
AIR RELIEF PLUG  
FOR CLAMP  
シールE  
(61E438619)  
裏面より  
FROM THE BACK

M8 クランプ用エア抜き  
AIR RELIEF PLUG  
FOR CLAMP  
シールE  
(61E438619)  
裏面より  
FROM THE BACK

リリーフバルブ  
RELIEF VALVE  
シールR  
(61E448855)  
裏面より  
FROM THE BACK

ネームプレート  
NAME PLATE  
(61E471615)

シール  
SEAL  
(61E471576)

リリーフバルブ  
RELIEF VALVE  
シールR  
(61E448855)

Rc3/8 ギヤボックス用潤滑油排水口  
DRAIN PORT  
FOR GEAR BOX  
シールC  
(61E430247)

Rc3/8 ギヤボックス用潤滑油供給口  
LUBRICATION PORT  
FOR GEAR BOX  
シールB  
(61E430246)

Rc3/8 傾斜軸潤滑油排水口  
DRAIN PORT  
FOR TILTING AXIS  
シールC  
(61E430247)

Rc3/8 回転軸潤滑油排水口  
DRAIN PORT  
FOR ROTATING AXIS  
シールC  
(61E430247)

**Kitagawa** MADE IN JAPAN

型式 Type: NC ROTARY TABLE TYPE

製造番号 MANUFACTURING NUMBER: TT182B\*\*

製造日 DATE OF MANUFACTURE: \*\*\*/\*\*/\*\*

質量 MASS: \*\*\*/\*\* kg

株式会社北川鉄工所 KITAGAWA IRON WORKS CO., LTD.

77-1 MOTOMACHI, FUCHU-SHI, HIROSHIMA, 726-8610, JAPAN

**CE**

銘番詳細  
Detail of name plate

油圧仕様のみ  
Only the HYDRAULIC  
エアバース用空気供給口  
PNEUMATIC PORT  
FOR AIR PURGE  
シールH  
(61E440091)

TT182, TW182のみ  
Only TT182 and TW182  
Rc1/4

傾斜軸サイレンサ  
SILENCER  
FOR TILTING AXIS  
シールT  
(61E456473)

傾斜軸クランプ用空気供給口  
PNEUMATIC PORT  
FOR TILTING AXIS  
TABLE CLAMP  
シールA  
(61E448856)

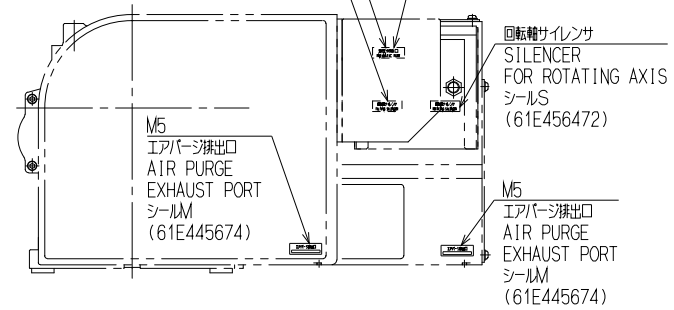

**要注意**

1. 図はTT182B5-03を例にメイバン位置を示しています。  
貼付け位置詳細は外形図を参考にしてください。

CAREER		SCALE	TYPE	TT182B5-03	WEIGHT	kg
MANAGER	CHIEF	DRAWN BY	NAME	NCテーブル NC ROTARY TABLE		
		H. ENDO		メイバン詳細図		
KITAGAWA IRON WORKS CO., LTD.		DATE	3RD ANGLE	DETAILS OF NAME PLATE		
		10.05.17		DRW NO.	61E807801	

1

2

5

6



<http://www.mta.kiw.co.jp>

## KITAGAWA IRON WORKS CO., LTD.

77-1 Motomachi Fuchu-shi, Hiroshima-pref., 726-8610, Japan

TEL +81-847-40-0526

FAX +81-847-45-8911

America Contact	<b>KITAGAWA-NORTHTECH INC.</b> <a href="http://www.kitagawa.com">http://www.kitagawa.com</a> 301 E. Commerce Dr, Schaumburg, IL. 60173 USA TEL +1 847-310-8787 FAX +1 847-310-9484
	<b>TECNARA TOOLING SYSTEMS, INC.</b> <a href="http://www.tecnaratools.com">http://www.tecnaratools.com</a> 12535 McCann Dr, Santa Fe Springs, California 90670 USA TEL +1 562-941-2000 FAX +1 562-946-0506
Europe Contact	<b>KITAGAWA EUROPE LTD.</b> <a href="http://www.kitagawaeurope.com">http://www.kitagawaeurope.com</a> Unit 1 The Headlands, Downton, Salisbury, Wiltshire SP5 3JJ, United Kingdom TEL +44 1725-514000 FAX +44 1725-514001
	<b>KITAGAWA EUROPE GmbH</b> <a href="http://www.kitagawaeurope.de">http://www.kitagawaeurope.de</a> Borsigstrasse 3, 40880, Ratingen Germany TEL +49 2102-123-78-00 FAX +49 2102-123-78-69
	<b>KITAGAWA EUROPE GmbH Poland Office</b> <a href="http://www.kitagawaeurope.de">http://www.kitagawaeurope.de</a> 44-240 Zory, ul. Niepodleglosci 3 Poland TEL +48 607-39-8855 FAX +48 32 -749- 5918
	<b>KITAGAWA EUROPE GmbH Czech Office</b> <a href="http://www.kitagawaeurope.de">http://www.kitagawaeurope.de</a> Lysicka 3, 621 00 Brno, Czech Republic TEL +420 603-856-122 FAX +420 549 -273- 246
	<b>KITAGAWA EUROPE GmbH Romania Office</b> <a href="http://www.kitagawaeurope.de">http://www.kitagawaeurope.de</a> Heliului 15, Bucharest 1 , 013991, Romania TEL +40 727-770-329 FAX +40 372-006-620
Asia Contact	<b>KITAGAWA INDIA PVT LTD.</b> Lotus House East, Lane 'E' North Main Road, Koregaon Park, Pune, 411 001, Maharashtra, India TEL +91 20-6500-5981 FAX +91 20-2615-0588
	<b>KITAGAWA (THAILAND) CO., LTD. Bangkok Office</b> 9th FL, Home Place Office Building, 283/43 Sukhumvit 55Rd. (Thonglor 13), Klongton-Nua, Wattana, Bangkok 10110, Thailand TEL +66 2-712-7479 FAX +66 2-712-7481
	<b>KITAGAWA IRON WORKS CO., LTD. Singapore Branch</b> #02-01 One Fullerton, 1 Fullerton Road, Singapore 049213 TEL +65 6838-4318 FAX +65 6408-3935
	<b>KITAGAWA IRON WORKS(SHANGHAI) CO., LTD.</b> Room 308 3F Building B, Far East International Plaza, No. 317 Xian Xia Road, Chang Ning, Shanghai, 200051 China TEL +86 21-6295-5772 FAX +86 21-6295-5792
	<b>DEAMARK LIMITED</b> <a href="http://www.deamark.com.tw">http://www.deamark.com.tw</a> No. 6, Lane 5, Lin Sen North Road, Taipei, Taiwan TEL +886 2-2393-1221 FAX +886 2-2395-1231
	<b>KITAGAWA KOREA AGENT CO., LTD.</b> <a href="http://www.kitagawa.co.kr">http://www.kitagawa.co.kr</a> 803 Ho, B-Dong, Woolim Lion's Valley, 371-28 Gasan-Dong, Gumcheon-Gu, Seoul, Korea TEL +82 2-2026-2222 FAX +82 2-2026-2113
Oceania Contact	<b>DIMAC TOOLING PTY. LTD.</b> <a href="http://www.dimac.com.au">http://www.dimac.com.au</a> 61-65 Geddes Street, Mulgrave, Victoria, 3170 Australia TEL +61 3-9561-6155 FAX +61 3-9561-6705

The products herein are controlled under Japanese Foreign Exchange and Foreign Trade Control Act. In the event of importing and/or exporting the products, you are obliged to consult KITAGAWA as well as your government for the related regulation prior to any transaction.

2015.06.