

INSTRUCTION MANUAL

UPR type

Large Thru-Hole Open Center Air Chuck



DANGER

- This instruction manual is for production engineers and maintenance personnel in charge of operation of this product. When a beginner uses this product, receive instructions from experienced personnel, the distributor or our company.
- Before installing, operating or maintaining this equipment, carefully read this manual and the safety labels attached to the equipment. Failure to follow these instructions and safety precautions could result in serious injury, death, or property damage.
- Store this manual near equipment for future reference.
- If any questions related to safety arise about this manual, please confirm them with the distributor or our company.

KITAGAWA IRON WORKS CO., LTD.

77-1 Motomachi, Fuchu, Hiroshima 726-8610 Japan

TEL +81-(0)847-40-0526

FAX +81-(0)847-45-8911

Preface

This manual provides detailed information about how to safely and correctly use the air chuck (UPR type) for a lathe.

Before starting to use this power chuck, read this manual carefully and always follow the instructions and warnings in "Important Safety Precautions" and "Precautions for Use" at beginning of the manual. Failure to follow these precautions could result in a serious accident.

Terms and Symbols Used for Safety Messages

In this manual, precautions for handling that are considered especially important are classified and displayed as shown below depending on the damage of risk including the seriousness of the harm that could result. Please sufficiently understand the meanings of these terms and follow the instructions for safe operation.



Safety Alert Symbol

The triangle is the safety alert symbol used to alert you to potential safety hazards that could result in injury or death.



Indicates a hazardous situation which, if you not avoided, will result in death or serious injury.



Indicates a hazardous situation which, if you not avoided, could result in death or serious injury.



Indicates a hazardous situation which, if you not avoided, could result in minor or moderate injury.



Indicates instructions which, if not avoided, could result in damage to the equipment or a shortened work life.

Liability and How to Use this Manual

This product is mounted on the both ends of the lathe spindle and is suitable mainly for gripping long pipes such as oil well pipes. This product is equipped with the jaws to clamp the workpiece and they operate by means of an air cylinder built in the chuck. For any other applications, please contact us.

Our company will not assume responsibility for injury, death, damage, or loss resulting from not following the instructions in this manual.

There are countless things that cannot or should not be done, and it is impossible to cover all of them in this manual.

Therefore, do not perform any actions unless they are specifically allowed in this manual. If any questions related to safety arise about operation, control, inspection and maintenance which are not specified in this manual, please confirm them with our company or distributor before performing them.

Guarantee and Limitation of Liability

The guarantee period of this product is 1 year after delivery.

Use the parts delivered by Kitagawa Iron Works for all the parts including consumable parts. We will not assume responsibility for injury, death, damage, or loss caused by usage of parts not manufactured by Kitagawa Iron Works. Additionally, if parts other than genuine parts manufactured by Kitagawa Iron Works are used, this guarantee will be completely invalid.

Table of Contents

1. Structural Drawing and Parts List -----	5
1-1. Type display	
1-2. Structural drawing	
1-3. Scope of product	
1-4. Parts list	
2.  Important Safety Precautions -----	13
3. Specifications -----	19
3-1. Specifications	
3-2. Relationship between gripping force and rotation speed	
3-3. Relationship between gripping part center height, static griping force and pneumatic pressure / Relationship between top jaw mass moment and gripping force loss	
4. Forming Soft Jaw -----	29
4-1. Attachment of soft jaw	
4-2. Forming soft jaw	
4-4. Forming method when you use forming jig	
5. Usage -----	33
5-1. Precautions during gripping work with chuck	
5-2. Precautions during gripping work in irregular shape	
5-3. Precautions related to usage of jaw	
5-4. Precautions related to processing	
5-5. Attachment of locator and jig	
6. Trial Run -----	36
7. Maintenance and Inspection -----	37
6-1. Periodic Inspection	
6-2. Grease lubrication	
6-3. Disassembling	

8. Malfunction and Countermeasures -----41
 8-1. In the case of malfunction
 8-2. Where to contact in the case of malfunction

For Machine Tool Manufacturers (Chapter 9)

9. Attachment -----43
 9-1. Outline drawing of attachment
 9-2. Manufacturing and attaching of back plate and support
 9-3. Piping
 9-4. Precautions related to pneumatic pressure
 9-5. Electric circuit diagram for reference
 9-6. Jaw stroke detection
 9-7. Chuck inner pressure detection
10. Other Information -----53
 10-1. About standards and orders
 10-2. Information about markings of product
 10-3. About disposal

1. Structural Drawing and Parts List

1-1. Type display

Type display as shown below

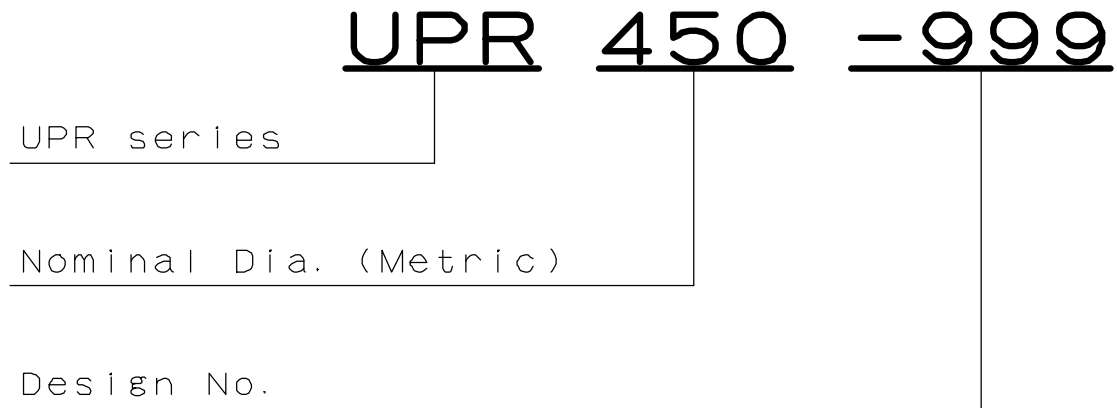

Fig.1

1-2. Structural drawing

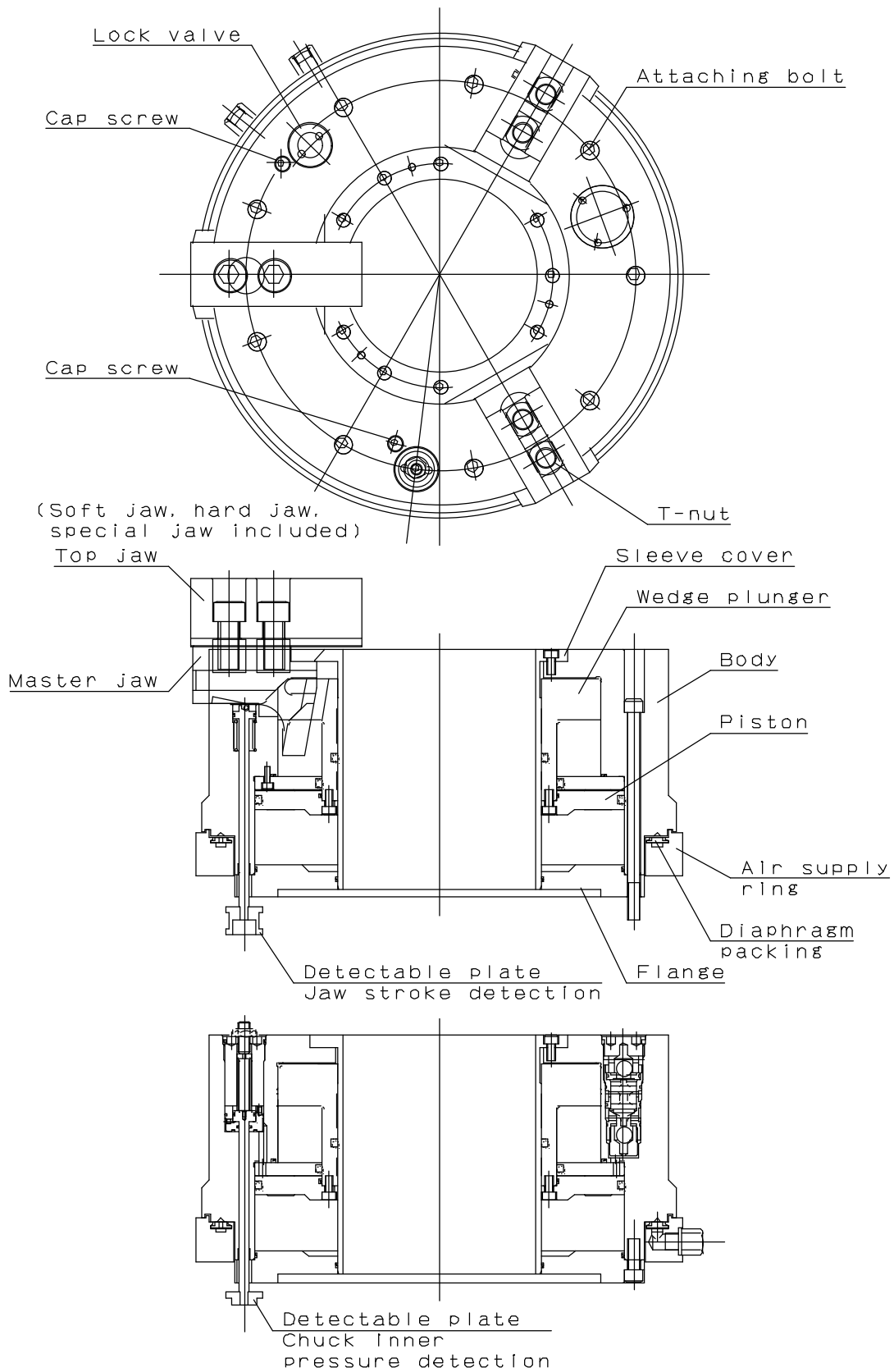

Fig.2 UPR Structural drawing

1-3. Scope of product

This instruction manual is for the chuck part.

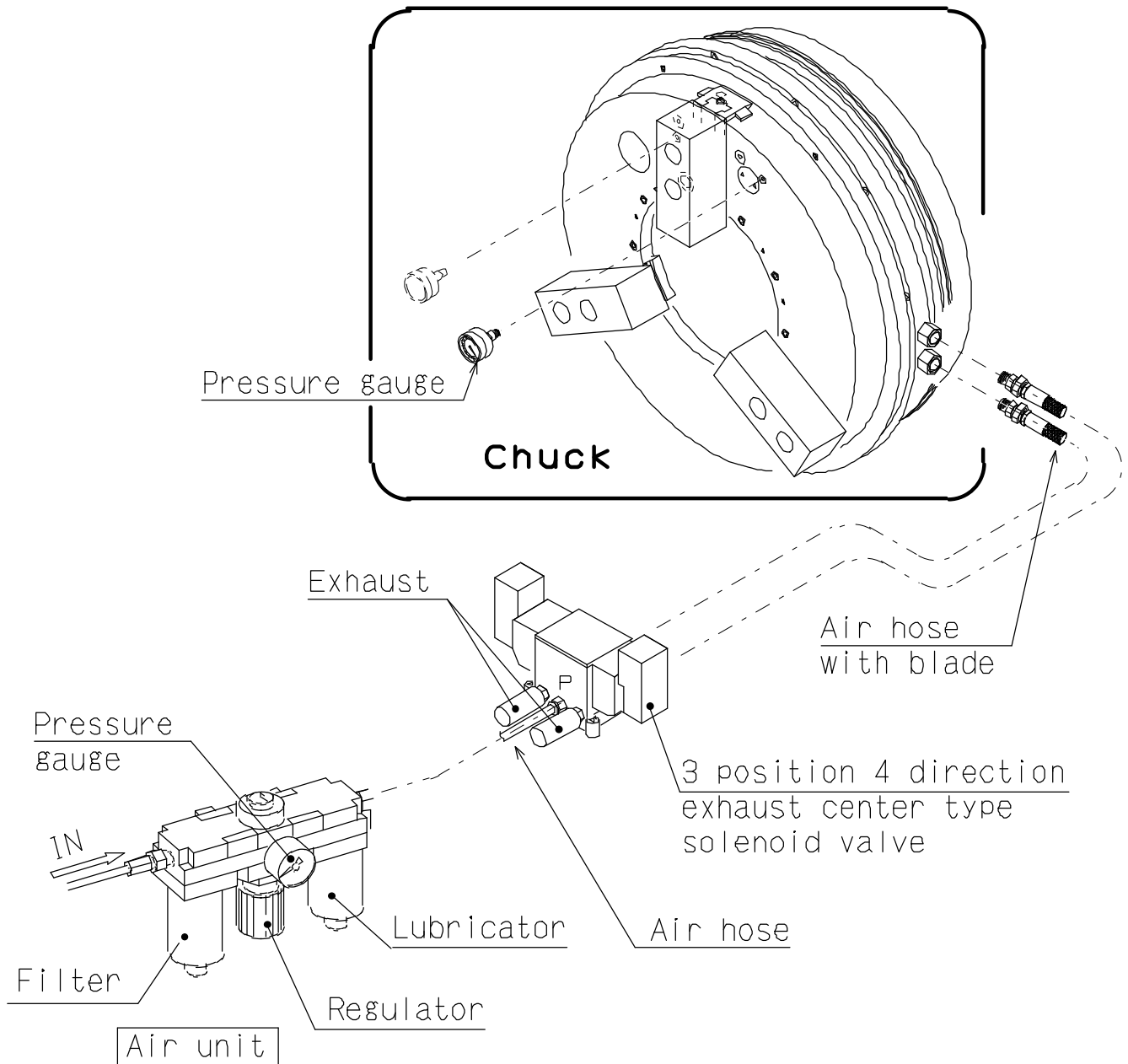

Fig.3

! WARNING

- To prevent the work from flying, safe design, maintenance and erroneous action prevention of the hydraulic system to maintain the gripping force of the chuck is extremely important. Thoroughly read the “Important Safety Precautions” on and after page 13 in this manual.
- For the usage of peripheral equipment, refer to the instruction manuals respectively.

1-4. Parts list

1. Chuck body

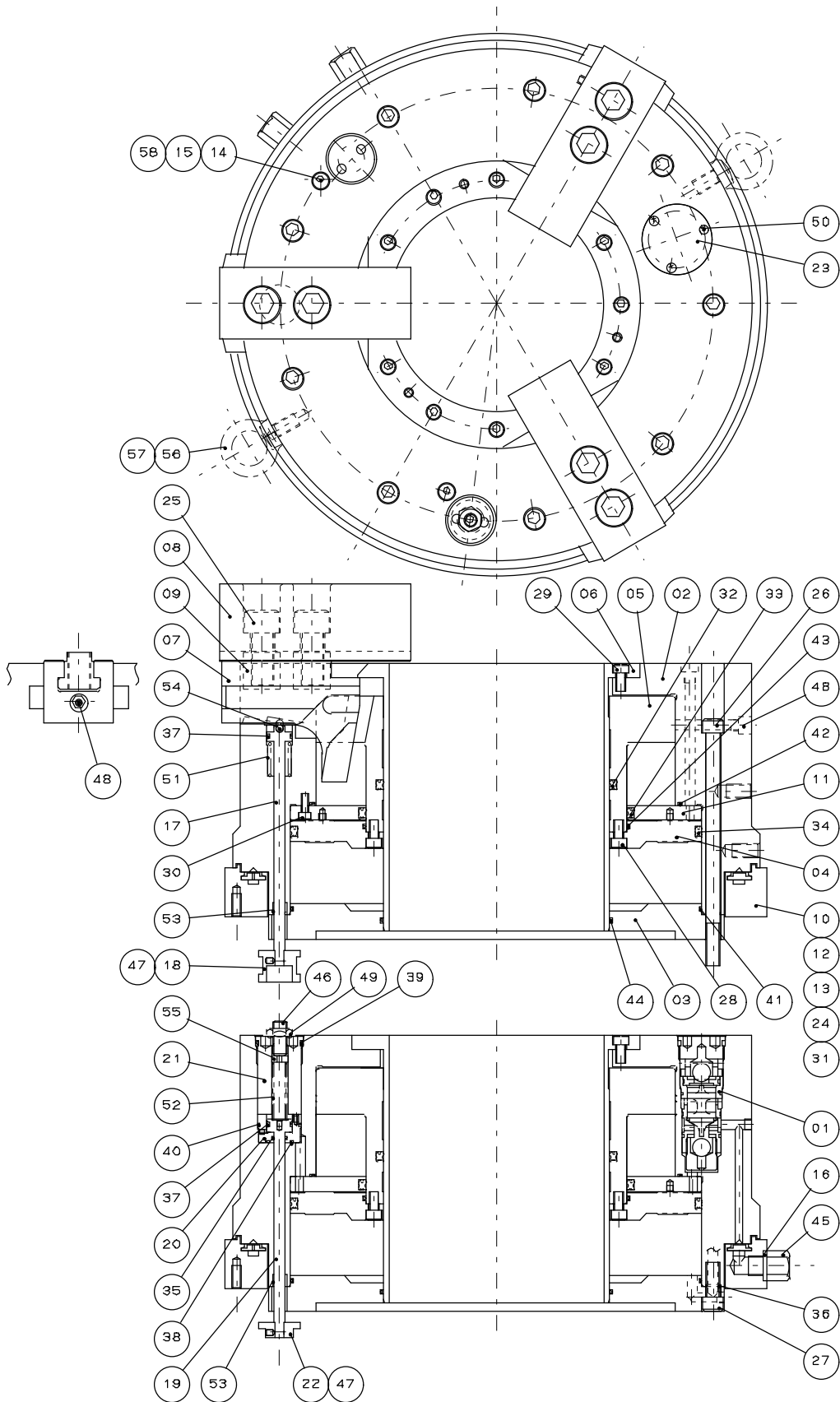

Fig.4

Table 1-1 Parts list

No.	Part name	Q'ty	No.	Part name	Q'ty
01	Lock valve	1	31	Button bolt	2
02	Body	1	32	X ring	1
03	Flange	1	33	X ring	1
04	Piston	1	34	X ring	1
05	Wedge plunger	1	35	O ring	1
06	Sleeve cover	1	36	O ring	1
07	Master jaw	3	37	O ring	2
08	Soft jaw	3	38	O ring	1
09	T-nut	6	39	O ring	1
10	Air supply ring	1	40	O ring	1
11	Cylinder cover	1	41	O ring	1
12	Diaphragm packing	1	42	O ring	1
13	Spacer	2	43	O ring	1
14	Cap screw	2	44	O ring	1
15	Seal washer	2	45	Hose adaptor	2
16	Seal packing	2	46	Set screw	1
17	Pilot spool	1	47	Set screw	4
18	Ditactable plate A	1	48	Grease nipple	6
19	Piston A	1	49	Nut	1
20	Cylinder A	1	50	Machine screw	3
21	Plug	1	51	Spring	1
22	Ditactable plate B	1	52	Spring	1
23	Name plate	1	53	Bushing	2
24	Simm	2	54	Steal ball	1
25	Jaw attaching bolt	6	55	Washer	1
26	Chuck attaching bolt	9 or 12	56	Eye bolt	2
27	Cap screw	9 or 12	57	Eye bolt	1
28	Cap screw	9 or 16 or 18	58	Pressure gauge	1
29	Cap screw	9 or 12	59	Hex. Key (1 set)	1
30	Cap screw	12 or 15			

Table 1-2 Consumption parts

No.	Part name	UPR450	UPR600	UPR650
01	Lock valve	61P401346	61P401346	61P401346
12	Diaphragm packing	61P814423	61P269500	61P269635
24	Simm	61P471720	61P471720	61P471720
32	X ring	X444	298.2 × 284.2 × 7	X456
33	X ring	X447	333.2 × 319.2 × 7	X459
34	X ring	X455	X466	X469
35	O ring	P 10	P 10	P 10
36	O ring	P 10	P 11	P 11
37	O ring	P 16	P 16	P 16
38	O ring	P 18	P 18	P 18
39	O ring	G 35	G 35	G 35
40	O ring	S 34	S34	S 34
41	O ring	GS 345	GS 470	525 × 3.1
42	O ring	GS 315	GS 395	GS 465
43	O ring	GS 225	GS 320	GS 380
44	O ring	GS 195	G 285	G 340

No.	Part name	UPR710	UPR910	
01	Lock valve	61P401346	61P401346	
12	Diaphragm packing	61P816122	61P816052	
24	Simm	61P473077	61P473077	
32	X ring	61P381520	591 × 578 × 7	
33	X ring	61P381518	631 × 618 × 7	
34	X ring	61P381519	765 × 752 × 7	
35	O ring	P 10	P 10	
36	O ring	P 11	P 11	
37	O ring	P 16	P 16	
38	O ring	P 18	P 18	
39	O ring	G 35	G 35	
40	O ring	S 34	S 34	
41	O ring	580 × 3.1	765 × 3.1	
42	O ring	525 × 3.1	710 × 3.1	
43	O ring	GS 430	605 × 3.1	
44	O ring	G 390	575 × 3.1	

2. Lock valve

The lock valve is the core part of this chuck. Please handle with care.

NOTICE

- Take care not to lose the spring when removing the lock valve.
- Apply the turbine oil type-1 additive free (ISO VG32) to the O-ring when inserting the lock valve into the chuck body.

WARNING

- Take care not to damage the O-ring when removing the lock valve and then reassembling it.
- Take care not to damage the ball and valve seat in the lock valve. Damaged parts reduce the gripping force, causing the workpiece to fly out.
- Take care not to attach dust when reassembling the lock valve. Assembling the lock valve with dust attached worsens the jaw operation or reduces the gripping force, causing the workpiece to fly out.

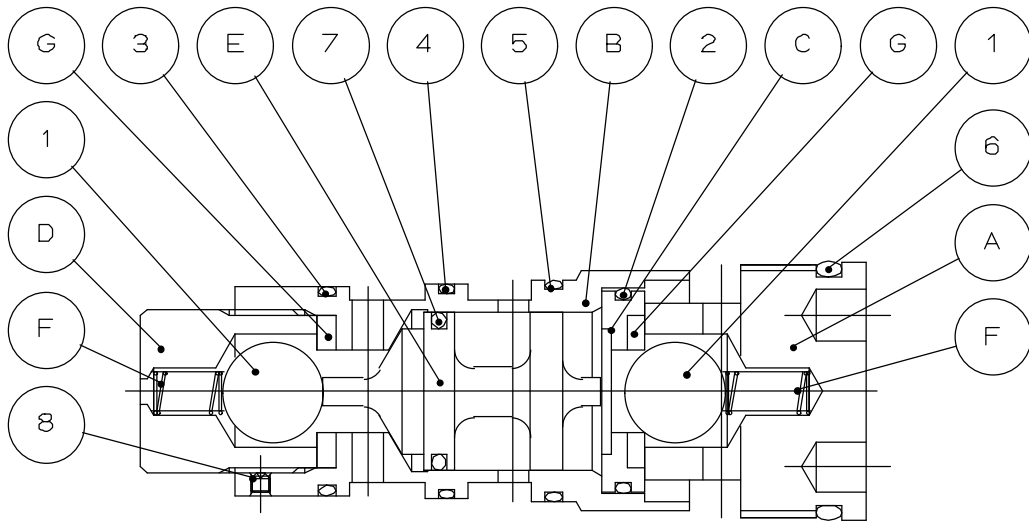

Fig.5

Table 2

No.	Part name	Part No.	Q' ty
A	Plug	61P401347	1
B	Housing	61P401348	1
C	Ring	61P401349	1
D	Cap	61P401350	1
E	Pilot spool	61P401351	1
F	Spring	61P401352	2
G	Valve seat	61P428716	2
1	Ball	16	2
2	O ring	S 29	1
3	O ring	S 29	1
4	O ring	S 30	1
5	O ring	S 31.5	1
6	O ring	G 35	1
7	O ring	P 20	1
8	Set screw	M3 × 3	1

2. Important Safety Precautions

Important safety precautions are summarized below. Please read this section before first starting to use this product.



DANGER

Failure to follow the safety precautions below will result in serious injury or death.



Turn off main power supply before attaching, inspecting or replacing chuck, and before adding oil.

For All Users

- The chuck may start rotation suddenly, and a part of the body or clothing may be caught.

Main power supply

OFF

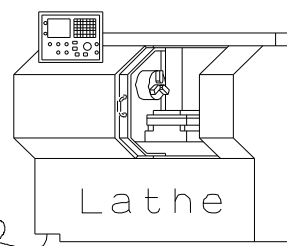
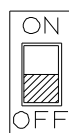

Close door before rotating spindle.

For All Users

- If the door is not closed, you may touch the rotating chuck or the work may fly out, which is very dangerous. (In general, the safety interlock function which allows rotation only when the door is the manual mode or the test mode)

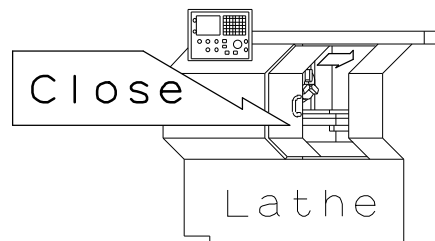

Do not internal gripping.

For All Users

- The chuck is damaged, causing the chuck and workpiece to be damaged or to fly out.



Grip the workpiece within the range of gripping stroke.

For All Users

- Within the jaw stroke range, grip the workpiece within the range of gripping stroke. If the workpiece is gripped within the range of rapid stroke, the gripping force is lost, causing the workpiece to fly out.



Important Safety Precautions



DANGER

Failure to follow the safety precautions below will result in serious injury or death.



The rotation speed of the chuck must not exceed the rotation speed limit against the pneumatic pressure. (Refer to pages 19-28)

For All Users

- If the chuck rotation speed exceeds the rotation speed limit, the chuck and workpiece may fly out.



Measure the maintained chuck internal pressure once a day.

For All Users

- Gripping force lowers due to air leakage, causing the workpiece to fly out.
- If the air leaks, it must be repaired.
- Remove the cap screw from the chuck body and install the pressure gauge attached and set the air pressure to the allowable maximum pressure, and if the pressure loss per one hour exceeds 0.05MPa, the chuck must be repaired.

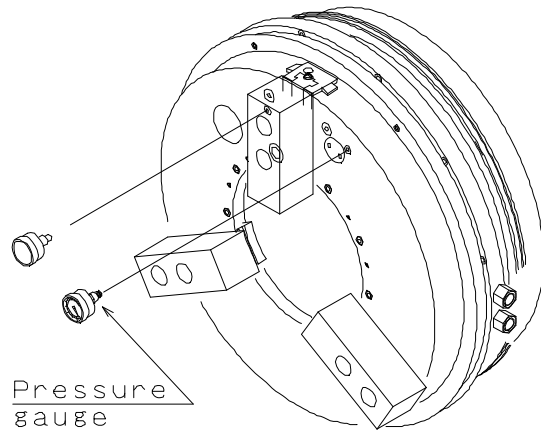

When the protrusion of the work is long, support it with the steady rest or center.

For All Users

- If the protrusion is long, the tip of the work can turn and the work fly out.



In the case of processing a significant unbalanced work, lower the rotation speed.

For All Users

- Unbalanced work generates dangerous centrifugal forces and the work could fly out.



Important Safety Precautions



DANGER

Failure to follow the safety precautions below will result in serious injury or death.



Always tighten the bolts at the specified torque. If the torque is insufficient or excessive, the bolt will break, which is dangerous as the chuck or work will fly out. Use the bolts attached to the chuck, and do not use bolts other than these.

For All Users

- If the torque is insufficient or excessive, the bolt will break, which is dangerous as the chuck or work will fly out.
- Fix the lathe spindle or the chuck when you tighten bolts. Your hand could slip and get injury when you work without fixing the spindle.
- You cannot control the torque by a hex key. You must use a torque wrench for torque control.

Specified torque for socket head cap screw

Bolt size	Tightening torque	
M5	7.5	N·m
M6	13	N·m
M8	33	N·m
M10	73	N·m
M12	107	N·m
M14	171	N·m
M16	250	N·m
M20	402	N·m
M22	539	N·m
M24	666	N·m

Tightening torque

$$\begin{aligned}
 T &= F \times L \\
 &= 127 \times 0.1 \\
 &= 12.7 \text{ (N} \cdot \text{m)}
 \end{aligned}$$

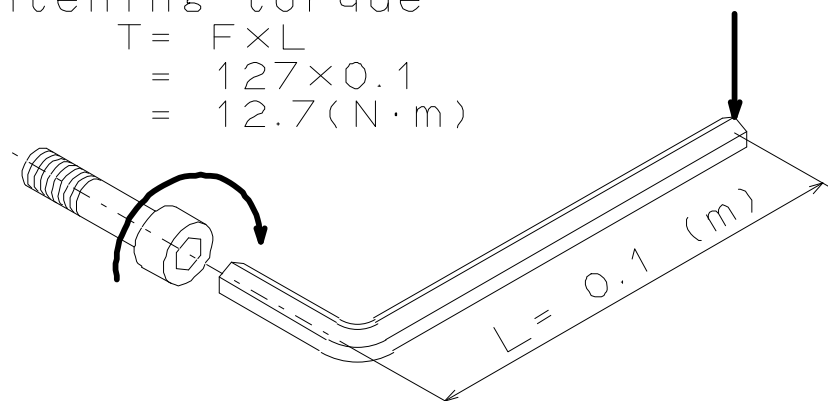

- Tightening torque is moment of force when you tighten a bolt. Tightening torque = $F \times L$.



Important Safety Precautions



DANGER

Failure to follow the safety precautions below will result in serious injury or death.



Keep the height of the jaw within the range specified in the gripping force limit table (Refer to pages 27-29). If you must use a jaw taller than a standard soft jaw, use less than the pneumatic pressure specified in the gripping force limit table.

For All Users

- Do not use a jaw of a height out of the range of the gripping force limit table or a jaw with mass moment out of the range of the gripping force limit table. The chuck will break and the chuck and work will break and fly out.

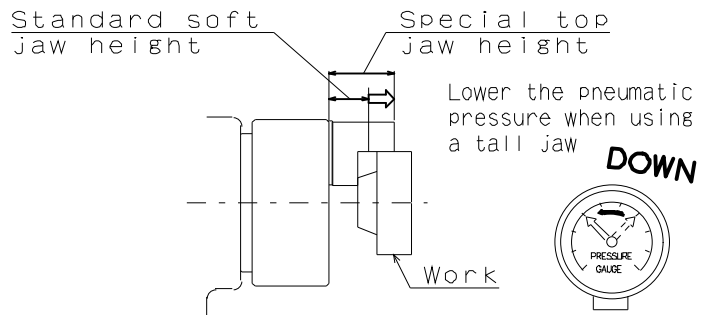

Determine the gripping force required for processing by the machine tool manufacturer or user, and check that the required gripping force is provided before processing. (Refer to pages 19-28)

For All Users

- Adjust the pneumatic pressure to the cylinder to obtain the required gripping force. If the gripping force is insufficient, this is dangerous as the work will fly out.



Such circuit must be designed that air cannot be supplied during spindle rotation.

For Machine Tool Manufacturers

- If air is supplied during spindle rotation, the diaphragm packing in the air supply ring will be damaged and the gripping force will be lost, causing the workpiece to fly out. For fail-safe operation, such circuit must be designed that air cannot be supplied during spindle rotation.



Such circuit must be designed that air is supplied for sufficient time to generate appropriate gripping force.

For Machine Tool Manufacturers

- If switching valve operation is performed, the jaws immediately operate to grip the workpiece. However, appropriate gripping force is not generated until the chuck internal pressure is stabilized at the setting pressure. Such circuit must be designed that air is supplied for sufficient time to generate appropriate gripping force. If the chuck internal pressure does not reach the setting pressure, the gripping force is lost, causing the workpiece to fly out. (Remove the cap screw from the chuck surface and install the pressure gauge attached, and then check the time until the chuck internal pressure reaches the setting pressure during air supply.)



Important Safety Precautions



WARNING

Failure to follow the safety precautions below could result in serious injury or death.



Maintain proper oil level of the lubricator in the air control unit. Drain water in the filter periodically.

(For details, refer to the instruction manuals respectively.)

For All Users

- Rust occurs in the cylinder, and the chuck operation fails or gripping force lowers, causing the workpiece to fly out.



The detection of chuck decompression is possible only when the supplied air pressure exceeds 0.35MPa (factory default setting). If machining is performed continuously over one hour, check for reduction in the internal pressure by the detectable plate for chuck decompression every hour. (Refer to pages 50-52)

For All Users

- If chuck internal pressure is reduced due to air leakage, gripping force lowers, causing the workpiece to fly out.
- If the air leaks, it must be repaired.
- As the detectable plate for chuck decompression functions only when the chuck stops, the chuck home position stop function is necessary on the machine side.



The workpiece must be re-gripped before machining if the machining is not performed over one hour after the air was fed.

For All Users

- If chuck internal pressure is reduced due to air leakage, gripping force lowers, causing the workpiece to fly out.



Do not attach the chuck vertically.

For All Users

- The chips and coolant enter the chuck, and the chuck operation fails or gripping force lowers, causing the workpiece to fly out.



Important Safety Precautions



WARNING

Failure to follow the safety precautions below could result in serious injury or death.



Do not modify the chuck in a way not permitted by the manufacturer.

For All Users

- It may not only break the chuck but the chuck and the work may fly out, which is dangerous.
- If you attach a locator or jig on the chuck body surface, only process work in an acceptable range (Refer to page 32).



Periodically supply adequate grease (Refer to pages 38-39). Turn off power before adding grease.

For All Users

- This is dangerous as the work could fly out from a drop in the gripping force.



Do not operate the machine after drinking alcohol or taking medication.

For All Users



Do not operate the machine wearing gloves, a necktie, and other loose clothing or jewelry.

For All Users

- Dangerous since these lead to operation mistakes and misjudgment.

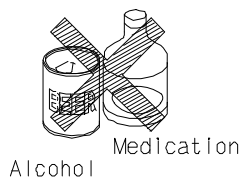

Alcohol

Medication

- Dangerous since it will be caught.



Do not grip a chuck with a chuck.

For All Users

- Because it is easy to confuse the specifications of each chuck and the protrusion become long and is apt to raise rotation speed, it is apt to exceed the specifications of the base chuck. The chuck may break and the chuck or work could fly out.

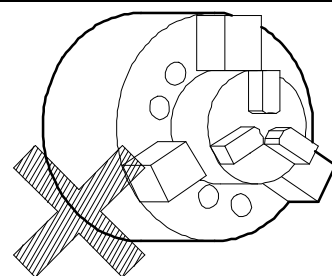

3. Specifications

3-1. Specifications

Table 3-1

Type		UPR450	UPR600	UPR650
Jaw stroke (in Dia.) mm	Rapid	26	33	33
	Gripping	14	17	17
Max gripping dia.	mm	441	590	655
Min gripping dia.	mm	127	235	240
Max static gripping force	kN	100	120	147
Max permissible speed	min ⁻¹	1300	1100	1000
Max pneumatic pressure	MPa	0.6	0.5	0.6
Mass	kg	195	365	476
Moment of inertia	kgm ²	5.5	19.7	32.2
Air consumption (at max pneumatic pressure, per stroke)	NI	51	76	95
Plunger stroke	mm	53	53.5	53.5
Cneter hole dia.	mm	185	275	325
Balance quality (Standard soft jaw not included)		G6.3		
Storing templatere / Operating templatere		-20 ~ +50 / -10 ~ +40		

Reference: 1kN = 101.97kgf 1MPa = 10.197kgf/cm²

When storing this product, the product should be subjected to the antirust treatment and stored in a place free from wetting, condensation, or freeze.

Table 3-2

Type		UPR710	UPR910	
Jaw stroke (in Dia.) mm	Rapid	33	33	
	Gripping	17	17	
Max gripping dia.	mm	715	915	
Min gripping dia.	mm	294	475	
Max static gripping force	kN	162	162	
Max permissible speed	min ⁻¹	900	600	
Max pneumatic pressure	MPa	0.6	0.5	
Mass	kg	532	735	
Moment of inertia	kgm ²	43.1	103	
Air consumption (at max pneumatic pressure, per stroke)	NI	119	125	
Plunger stroke	mm	53.5	53.5	
Cneter hole dia.	mm	375	560	
Balance quality (Standard soft jaw not included)		G6.3		
Storing templatere / Operating templatere		-20 ~ +50 / -10 ~ +40		

Reference: 1kN = 101.97kgf 1MPa = 10.197kgf/cm²

When storing this product, the product should be subjected to the antirust treatment and stored in a place free from wetting, condensation, or freeze.

3-2. Relationship between gripping force and rotation speed

1. Maximum static gripping force

The static gripping force is the gripping force when the chuck is at a stop.

The air chuck has a mechanism to convert pneumatic pressure to gripping force. Therefore, the gripping force when the maximum pneumatic pressure becomes the maximum static gripping force.

However, the gripping force is different depending on the state of grease lubrication, grease in use, height of the jaw, etc. The maximum static gripping force specified in the specification is the value under the following conditions:

- The numerical values are obtained with the Kitagawa gripping force meter . The gripping position of the gripping force meter is at a position 1/2 of the height of the soft jaw top surface (height from the chuck surface to the top surface of the jaw).
- The attaching bolts of the soft jaw are tightened at the specified torque. (Refer to page 15)
- CHUCK GREASE PRO is used. (Refer to page 38).
- Max pneumatic pressure.

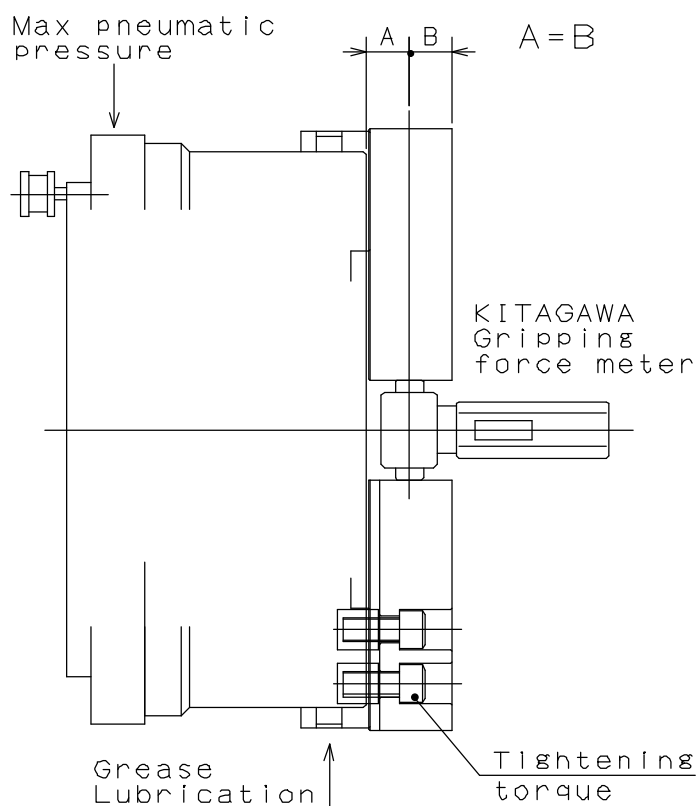

Fig.6

2. Allowable maximum rotation speed

In the case of outside diameter gripping, when the chuck is rotated, the gripping force lowers due to the centrifugal force of the top jaw. Therefore, the rotation speed when the dynamic gripping force (gripping force during rotation) becomes approximately 1/3 of the maximum static gripping force is set as the allowable maximum rotation speed. The centrifugal force is different depending on the mass of the top jaw and the barycentric position as well as the rotation speed. The allowable maximum rotation speed specified in the specification is the value under the following conditions:

- The Kitagawa standard soft jaw is used.
- Grip the gripping force meter in the center of the jaw stroke, and at this point, the soft jaw is attached at the position where the periphery side end of the soft jaw and the chuck periphery are almost lined up.
- The numerical values are obtained by the Kitagawa gripping force meter. The gripping position of the gripping force meter is at a position 1/2 of the height of the soft jaw top surface (height from the chuck surface to the top surface of the jaw).



To avoid serious accidents caused by the chuck or work flying out:

- **Determine the gripping force required for processing by the machine tool manufacturer or user, and check that the required gripping force is provided before processing. The gripping force of the chuck must not exceed the maximum static gripping force.**
- **Determine the rotation speed required for processing by the machine tool manufacturer or user based on the gripping force required for the processing. The rotation speed at this point must not exceed the allowable maximum rotation speed.**

NOTICE

- When determining the cutting conditions, refer to pages 22-28.
- Pay attention since the gripping force is different depending on the state of the oil supply, grease in use, height of the jaw, performance of the pump and the pressure reducing valve, piping state, etc.

3. Relationship between gripping force and rotation speed

As the rotation speed becomes higher, the centrifugal force of the jaw increases and the gripping force lowers. The curves displayed in Fig. 7 shows relationships between the rotation speed and the centrifugal force when using the standard soft jaw. The centrifugal force differs significantly depending on the size and shape of the top jaw and the attaching position, therefore, when the rotation speed is high, actual measurement using a Kitagawa gripping force meter is required.

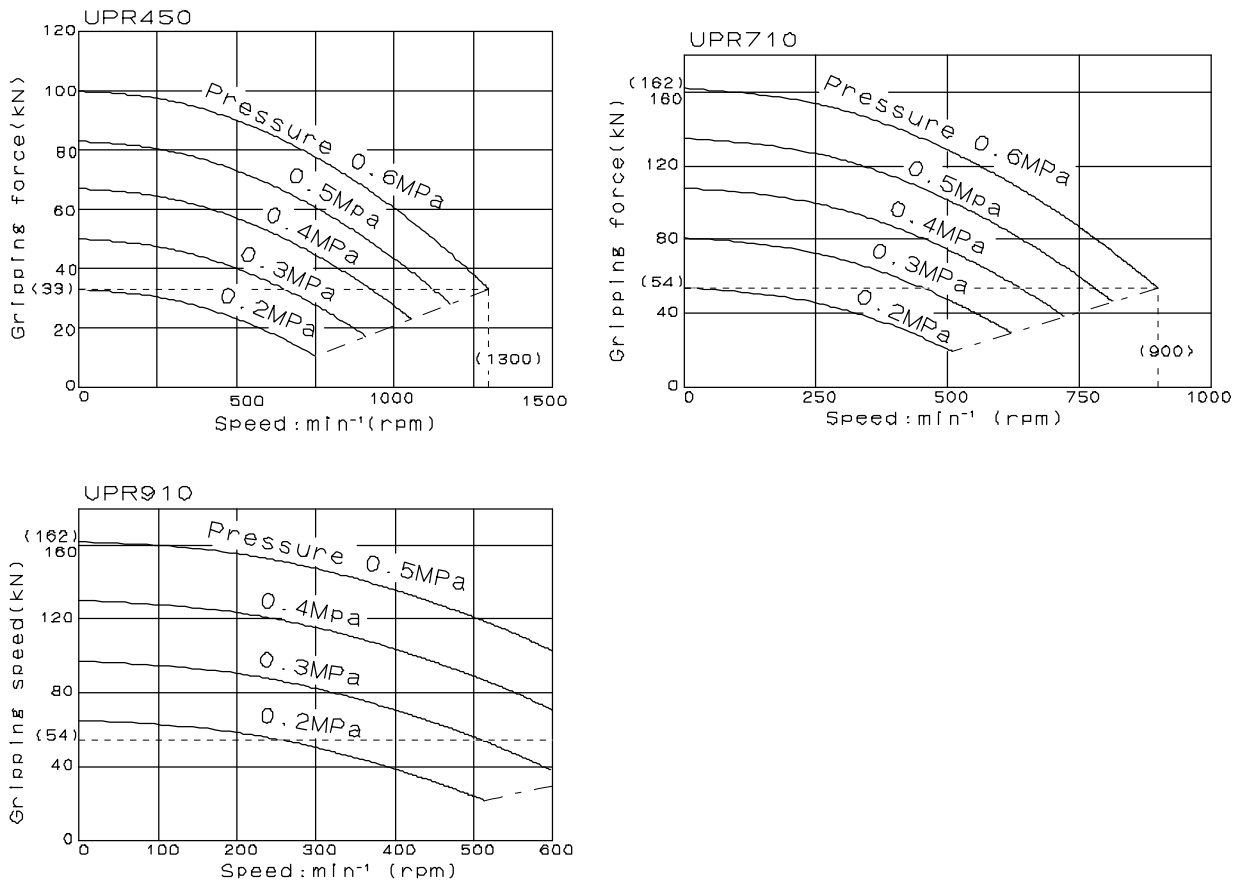

Fig.7



DANGER

- In the case of processing a considerably unbalanced work, lower the rotation speed. The work will fly out and this is dangerous.
- Vibration is generated if there is unbalance due to the work and the jig, etc. Vibration decreases process precision and shortens the working life of the chuck, even possibly breaking it. Correct the unbalance by using a balance weight, etc., or lower the rotation speed for use.
- In the case of heavy cutting at high rotation speed, vibration is easily generated in the same manner as the unbalance of the chuck, therefore, set the cutting conditions appropriate for the dynamic gripping force and machine rigidity.

3-3. Relationship between gripping part center height, static gripping force and pneumatic pressure / Relationship between top jaw mass moment and gripping force loss

If the gripping part center height of the used top jaw (dimension H in Fig. 8) is higher than the gripping part center height of the standard soft jaw, a large load is applied to the master jaw, T nut, jaw attaching bolts, etc. To prevent these parts from being broken, it is necessary to use the machine by using a lower pneumatic pressure than the allowable maximum pneumatic pressure.

Additionally, if the top jaw is larger and heavier, the centrifugal force generated at the top jaw will increase. It is necessary to examine the dynamic gripping force considering the centrifugal force and to use the machine at a rotation speed that can withstand the cutting force.

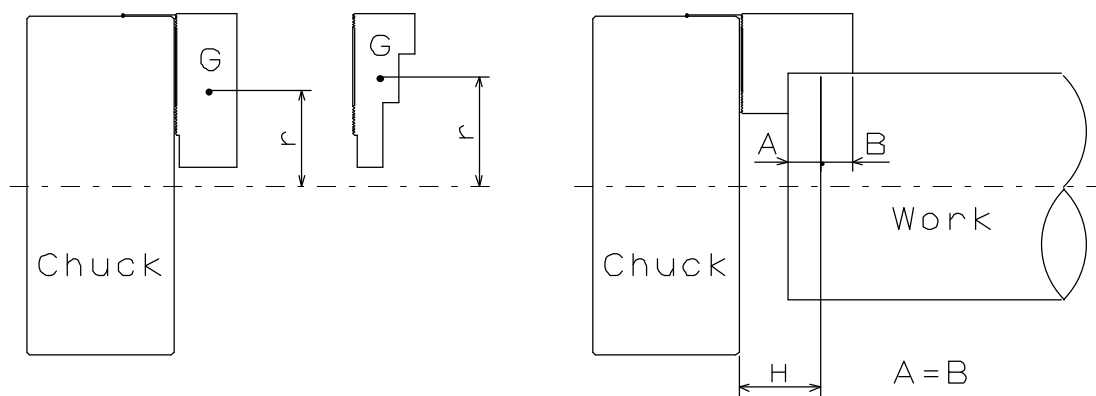

G: Center of mass of the top jaw

m: Mass of the top jaw

r: Distance from the center of mass of the top jaw to the chuck center

H: Gripping center height

Fig.8



- **Keep the height of the top jaw within the range of the gripping force limit table. (Refer to Fig.9)**
- **If a top jaw is taller than the standard soft jaw, use it at the pneumatic pressure specified in the gripping force limit table. If it is used without lowering the pressure, the chuck will break and this is dangerous as the chuck and work will fly out.**

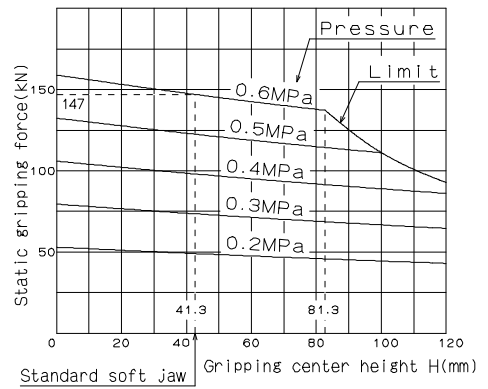
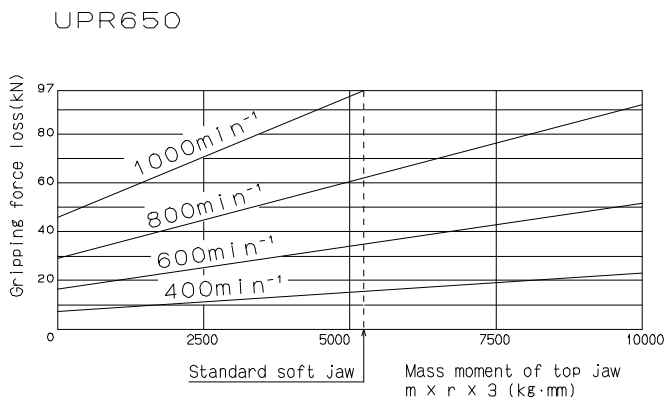
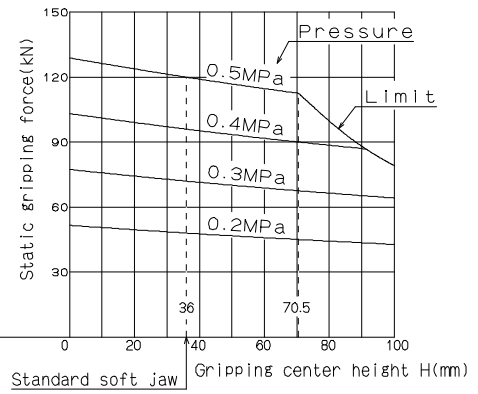
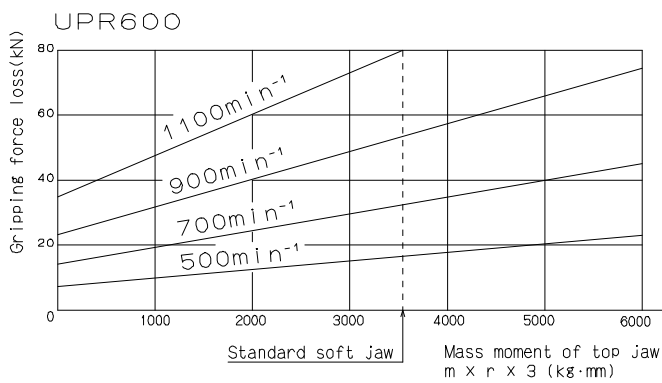
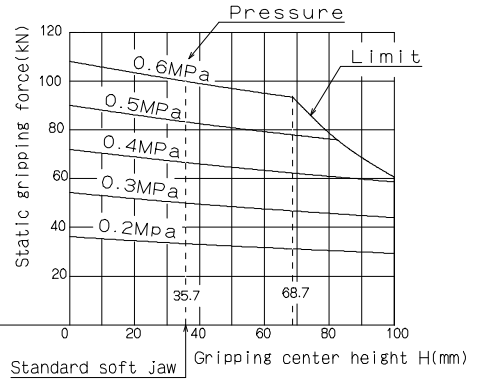
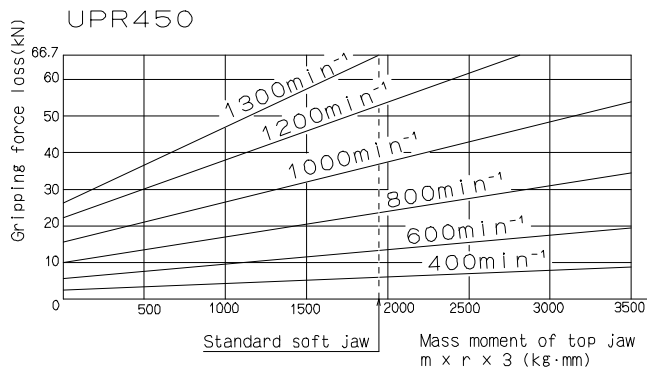

Fig.9-1

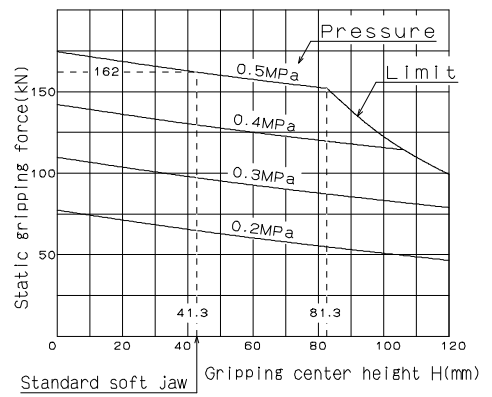
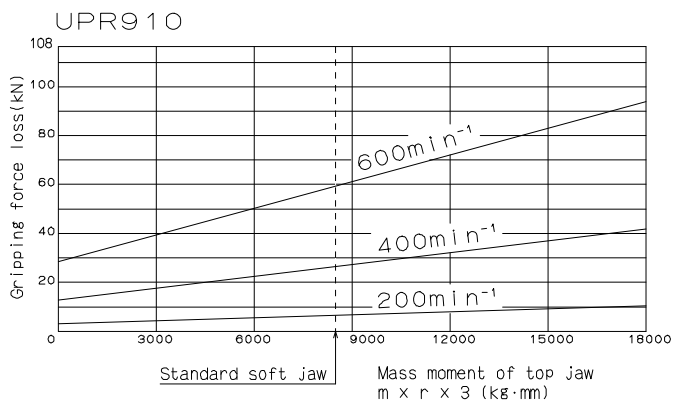
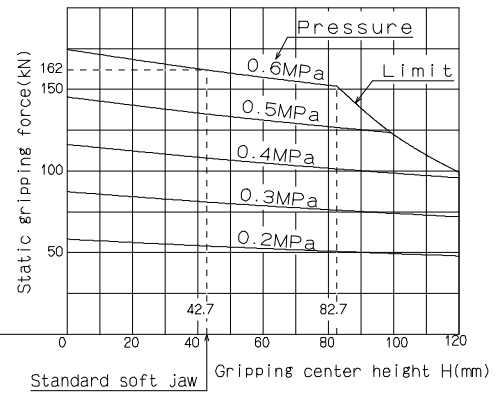
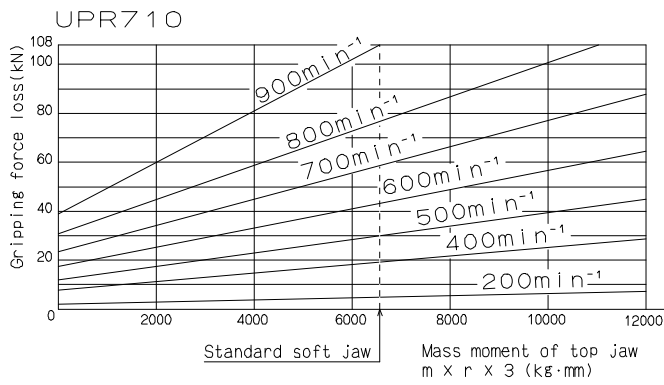

Fig.9-2

NOTICE

Analysis of the gripping force, pneumatic pressure and rotation speed using Fig. 9 is carried out as shown below.

- For example, in the case of UPR450 standard soft jaw (mass moment $1891\text{kg}\cdot\text{mm}$), it cannot exceed 1300min^{-1} (rpm), and the gripping force loss due to the centrifugal force at this rotation speed is 66.7kN. The required static gripping force for the dynamic gripping force (gripping force loss by static gripping force - centrifugal force) to become 1/3 of the static gripping force is 100kN, and the required pneumatic pressure to obtain this gripping force is 0.6MPa. However, it is necessary to use at the gripping part center height $H=35.7$ mm or less.
- If the gripping part center height H is high, it is necessary to lower the static gripping force.
- If the top jaw mass moment is large, the rotation speed needs to be lowered.
- If the rotation speed is high, the gripping force loss due to the centrifugal force becomes large. The centrifugal force is proportional to the square of the rotation speed.

The required static gripping force and pneumatic pressure required at the rotation speed in use are predicted from Fig.9, however, it contains a number of hypothetical conditions. Therefore, it is necessary to only use these as reference, and the processing conditions must be determined after trial cutting without fail.

DANGER

- **In the case of using only 1 jaw for gripping reduce the input force by 2/3 or more. If 2 jaws are used for gripping reduce the input force by 1/3 or more. If it is used without lowering the input, the input which is normally applied evenly onto 3 of the jaws is concentrated onto 1 or 2 of the jaws. Otherwise the chuck will break, the work will fly out and this is dangerous.**

4. Forming Soft Jaw

4-1. Attachment of soft jaw

The attaching position of the soft jaw can be adjusted by loosening the socket head cap screw, attaching the soft jaw and by changing each serration engagement position.

Use the most appropriate soft jaw considering the shape, dimension, material, and surface roughness of the work and the cutting conditions, etc.



- Use the T nut so that it does not come out from the master jaw. (Refer to Fig.10)
- If the T nut comes out from the master jaw, the master jaw and T nut will break causing the work to fly out and a possible precision failure.

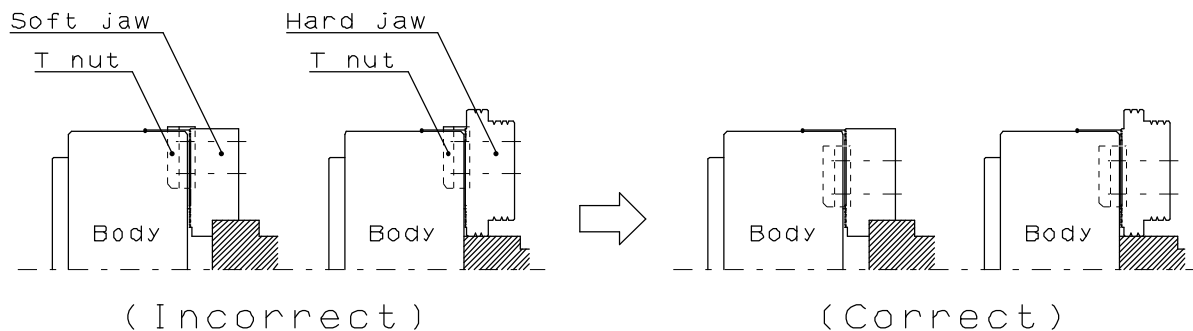

Fig.10

- Always tighten the bolts at the specified torque. If the torque is insufficient or excessive, the bolt will break, which is dangerous as the chuck or work will fly out.

Table 4

Bolt size	Tightening torque	
M5	7.5	N·m
M6	13	N·m
M8	33	N·m
M10	73	N·m
M12	107	N·m
M14	171	N·m
M16	250	N·m
M20	402	N·m
M22	539	N·m
M24	666	N·m

! DANGER

- If the screw-in depth of the jaw attaching bolt to the T nut is shallow, the T nut will break, and this is dangerous as the jaw and work will fly out. If the attaching bolt is too long and comes out from the bottom of the T nut as well, this is dangerous as the jaw and work will fly out since the top jaw is not fixed. Therefore, the overall length of the jaw attaching bolt must be approximately 0 to -1mm from the bottom of the T nut (Refer to Fig.11).
- Use the T nut and the attaching bolts attached to the chuck and do not use bolts other than these. If commercially available bolts are used for an unavoidable reason, use bolts at the strength classification 12.9 (strength classification 10.9 for M22 or more) or more, and pay sufficient attention to the length.

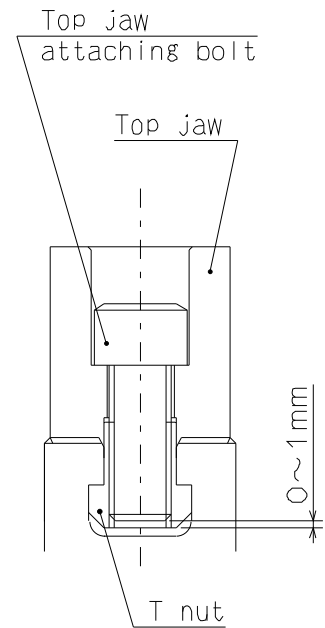

Fig.11

- Do not rotate the chuck so that the T nut is loosened causing the jaw to fly out.
- When gripping the work, use it by keeping the position of the master jaw within the appropriate stroke range. Gripping in the center of the stroke is the most stable for the mechanism, and the best precision can be obtained.
 - If the workpiece is gripped within the range of rapid feed stroke, the gripping force is lost, causing the workpiece to fly out.
 - When gripping near the stroke end, the work may not be gripped sometimes according to the deviation, etc., of the gripping part allowance of the work, and this is dangerous as the work will fly out.
 - When gripping near the stroke end, the chuck may break and the chuck or work could fly out.

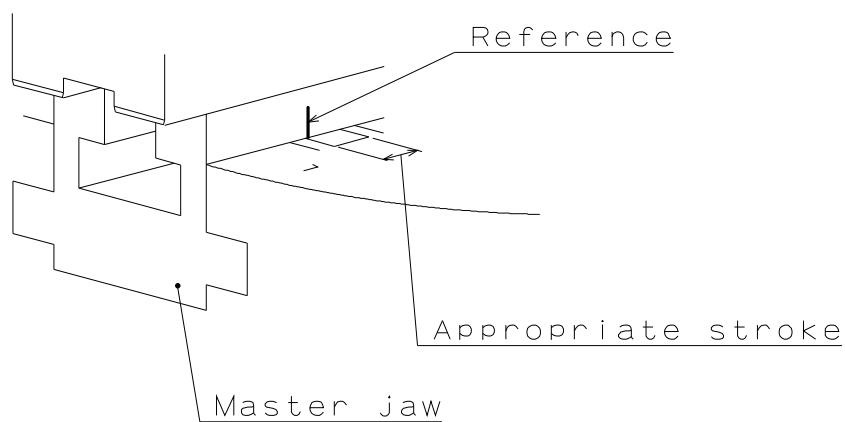
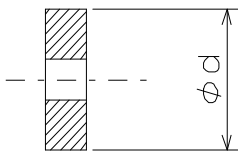
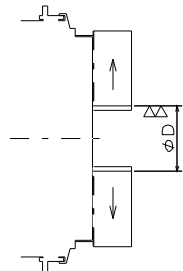
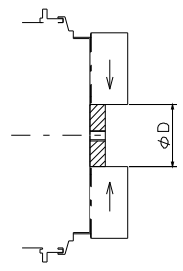
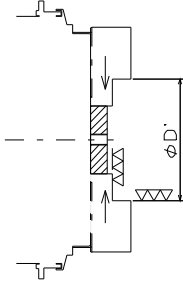
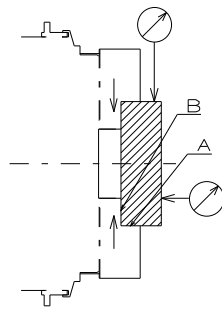
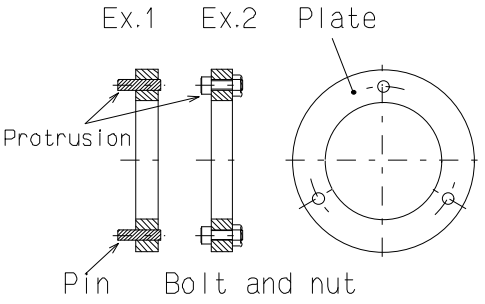
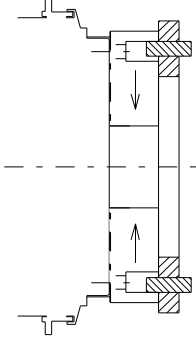
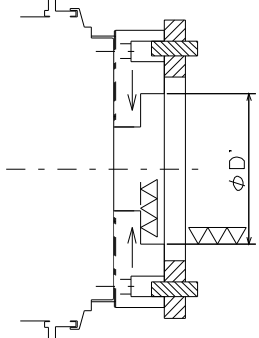
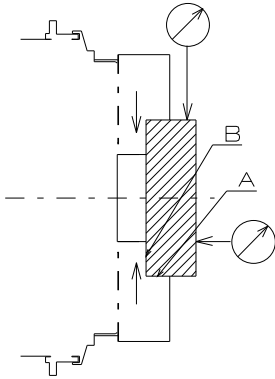

Fig.12

4-2. Forming soft jaw

<p>1. Preparation of the plug for forming</p> <ul style="list-style-type: none"> Prepare the plug for forming. The surface roughness of the plug outside diameter is to be approximately 25s, and make a shape with sufficient thickness which does not distort. It is convenient to prepare various outside diameter dimensions for dimensions of forming parts. It is convenient to process tapping in the center part of the plug and to guide with a bolt, etc. 	
<p>2. Process of the plug gripping part for forming</p> <ul style="list-style-type: none"> Operate the switch valve and maximize the opening of the jaw. Then, process the D part (part to grip the plug for forming). Set the dimension D so that gripping near the center of the jaw maximum stroke (diameter) is possible. $D = d + (\text{jaw maximum stroke}/2)$ 	
<p>3. Gripping of the plug for forming</p> <ul style="list-style-type: none"> By operating the switch valve, grip the plug for forming in the D part. At this time, grip by pressing the plug on the chuck front surface in order for the plug not to be tilted. Repeat chucking several times to stabilize the plug. 	
<p>4. Forming</p> <ul style="list-style-type: none"> Process the gripping part (dimension D') of the work in the state that the plug is kept gripped. The D' part is to be approximately the same diameter (H7) as the diameter of the gripping part of the work, and process to be surface roughness at 6s or less. Set the hydraulic pressure during forming the same as during processing of the work, or slightly higher. When the plug distorts, lower the hydraulic pressure or change the plug into a shape which does not easily distort. 	
<p>5. Trial cutting</p> <ul style="list-style-type: none"> Remove the plug for forming and grip the work to check the jaw stroke. Implement trial cutting to check the process precision and that there is no slip, etc. Contacting on the gripping surface is to be 2 points contact of the side A and the side B when gripping. 	

4-3. Forming method when you use forming jig

<p>1. Preparation of the jig for forming</p> <ul style="list-style-type: none"> Prepare the jig for forming. (There is a commercially available product.) Attach the pin (Example 1) or the bolt and nut (Example 2) by dividing equally into 3 portions onto the ring shape plate. Make the ring into a shape with sufficient thickness which does not distort. 	
<p>2. Gripping of the jig for forming</p> <ul style="list-style-type: none"> Operate the switch valve and maximize the opening of the jaw. Then, operate the switch valve to insert the jig for forming into the bolt hole of the soft jaw to grip. At this time, grip by pressing the ring end surface of the jig for forming onto the jaw so as not to generate run-out. Check that it is gripping almost in the center of the appropriate stroke. Set the hydraulic pressure when forming slightly higher than when processing the work. 	
<p>3. Forming</p> <ul style="list-style-type: none"> Process the gripping part (dimension D') of the work in the state that the jig for forming is kept gripped. The D' part is to be approximately the same diameter (H7) as the diameter of the gripping part of the work, and process to be surface roughness at 6s or less. 	
<p>4. Trial cutting</p> <ul style="list-style-type: none"> Remove the jig for forming and grip the work to check the jaw stroke. Implement trial cutting to check the process precision and that there is no slip, etc. Contacting on the gripping surface is to be 2 points contact of the side A and the side B when gripping. 	

5. Usage

This product is used to clamp a workpiece when machining it on a lathe.

The built-in air cylinder moves the jaws toward the closing side to grip the workpiece, so that the workpiece is clamped during the machining. After the machining, the jaws move toward the open side to allow the workpiece to be removed.

NOTICE

- When replacing the top jaw, carefully clean the serration part with the master jaw, and the engagement part of the T nut. Failure to do this may cause a precision failure.
- Set the hydraulic pressure according to the shape of the work and the cutting conditions. Pipe shape work, etc., may be distorted if they are tightened at a high gripping force.

5-1. Precautions during gripping work with chuck

DANGER

- When gripping a work with the chuck, do not get fingers or hands become caught. This could cause crushed or cut fingers and hands.

5-2. Precautions during gripping work in irregular shape

DANGER

- If a work in an irregular shape is gripped the master jaw may be broken. Consult our company or the distributor if there is any concern.
- Cast metal, pitched shape or taper shape cannot be gripped.
- If the protrusion of the work is long, support it with a center or the steady rest. If the protrusion is long the tip of the work turns, and this is dangerous as the work will fly out.

5-3. Precautions related to usage of jaw



- If a soft jaw other than one made by Kitagawa Iron Works is used, the engagement will be inferior, and the master jaw will be deformed, the gripping precision will worsen, and the work will fly out due to gripping failure, which is dangerous.
- Do not use a top jaw with a different serration pitch from the master jaw. The engagement of the crests of the serration will become insufficient, therefore, the serration crests will break when gripping the work, and this is dangerous as the jaw and work will fly out.
- Do not use the soft jaw by welding to join for extension. The jaw will break due to insufficient strength and the serration part will become distorted due to welding. As a result, the engagement will worsen, the serration crests will break, and this is dangerous as the work will fly out.

5-4. Precautions related to processing



<1> Unbalance

- In the case of processing largely unbalanced work, lower the rotation speed. The work will fly out and this is dangerous.
- Vibrations are generated if there is unbalance owing to the work or the jig, etc. Vibration not only will impart a negative influence on the process precision but also the endurance of the chuck being remarkably shortened, and the chuck may break. Correct the unbalance using balance weights, etc., or lower the rotation speed for use.
- Heavy cutting at high rotation speed easily generates vibration in the same manner as chuck unbalance, therefore, set cutting conditions appropriate for the dynamic gripping force and machine rigidity.

<2> Interference, contact, impact

- Before starting work, check that the top jaw, locator, work, etc., and the tool and the tool post, etc., do not interfere at low rotation and then start processing.
- Do not allow anything to impact the chuck, jaw, and the work. The chuck will break and this is dangerous as the chuck and work will fly out.
- If the tool and the tool post contact the chuck or the work due to malfunction

or tape mistake, etc., and impact is given, immediately stop the rotation, and check that there are no abnormalities in the top jaw, master jaw, T nut and bolts of each part, etc.

<3> Coolant

- Unless coolant with a rust preventive effect is used, rust will occur inside the chuck and gripping force drop may result. The work will fly out due to the gripping force drop and this is dangerous.

5-5. Attachment of locator and jig

- In the case of attaching the locator and the jig on the chuck body surface, tap or drill a hole in the additional process range specified in Fig. 13.

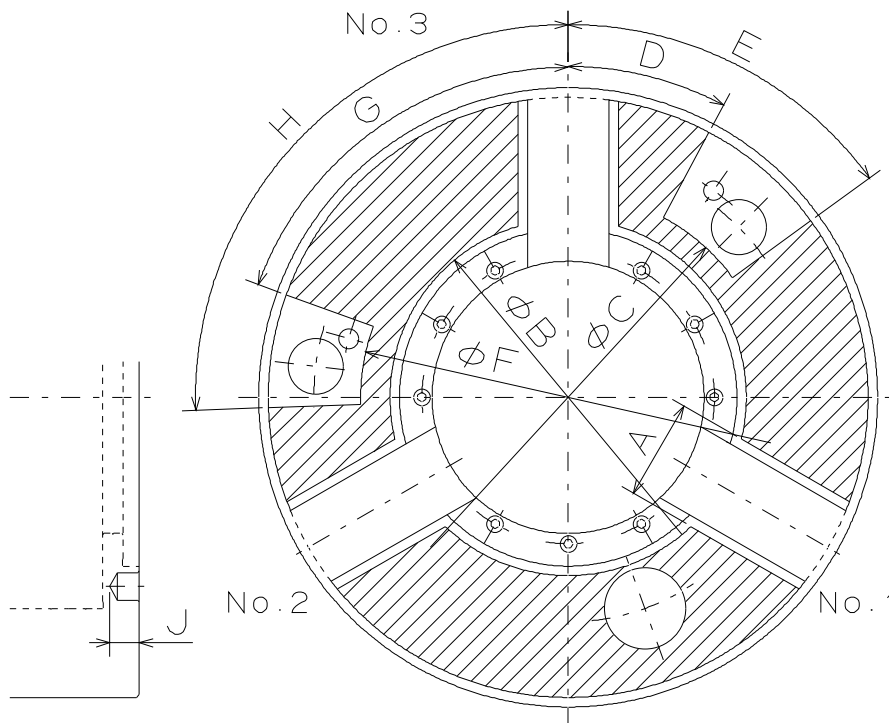

Fig.13

Table 5

	UPR450	UPR600	UPR650	UPR710	UPR910
A	100	100	120	120	120
B	262	364	419	469	657
C	299	405	475	535	723
D	26	18	18	23	23
E	54	40	45	45	42
F	305	438	487	546	745
G	70	49	50	35	56
H	92	69	69	51	64
J	21	26	32	32	31

(mm)



- **The chuck can be modified only in the manufacturer permissible range. This will not only break the chuck but the chuck and work may fly out, which is dangerous.**
- **Provide a countermeasure against flying out (dwell pin, etc.) due to centrifugal force to the locator or the jig, and attach with bolts which have sufficient strength. The locator or the jig may fly out, and this is dangerous.**

6. Trial Run

Thoroughly read the “Important Safety Precautions” on and after page 13 in this manual before trial run.

1. Supply the specified grease to the grease nipples on the master jaws and body circumference. (Refer to page 38)
2. Fill the lubricator with the turbine oil class-1 additive-free (ISO VG32) to the upper limit. At this time, do not allow the dust to enter.
3. Set the pneumatic pressure to 0.2MPa and operate the switching valve to check that the jaws move over full stroke completely.
4. Adjust drips in the lubricator. Appropriate amount of lubricant drips is one drip per two or three times of chucking.
5. Set the pneumatic pressure to 0.5MPa and operate the switching valve to check respective parts for air leakage and abnormality.
6. Rotate the spindle at a speed of 100 - 200min⁻¹. When vibration or noise is generated, check the back plate and the chuck body for significant runout, or check that the air supply ring does not come into contact with the chuck body.

7. Maintenance and Inspection

7-1. Periodic Inspection

- Supply oil to the master jaws at least once a day, and to the body circumference at least once a week.
- Always clean the chuck body or the sliding surface using an air gun, etc., at the end of work.
- Check that the bolts of each part are not loosened at least once every 3 months.
- Disassemble and clean at least once every 6 months or every 100,000 strokes (once every 2 months or more for cutting cast metal).
- If the chuck has not been used for more than one week, operate the chuck with no load at least 10 times and check drips of lubricator before starting the machining.
- Check for water in the air filter and drain it periodically, which otherwise causes rust.
- Supply oil to the lubricator so as to maintain proper oil level range. Use the turbine oil type-1 additive free (ISO VG32).
- Measure the maintained air pressure once a day. Remove the cap screw from the chuck body and install the pressure gauge attached and set the air pressure to the allowable maximum pressure, and if the pressure loss per one hour exceeds 0.05MPa, the chuck must be repaired.
- After the pressure measurement, apply the turbine oil class-1 additive-free (ISO VG32) to the pressure gauge mounting hole and retighten the cap screw.

CAUTION

- **When installing the pressure gauge, operate the chuck so that the master jaws are closed, and loosen slowly the cap screw at the front of chuck body to discharge the air completely from the cylinder. Loosening the cap screw with internal pressure remained causes the cap screw to fly out due to the internal pressure.**

7-2. Grease lubrication

1. Position to lubricate

- A total of six grease nipples are provided on each master jaw and the body circumference (at three points). Supply oil to the master jaws with the jaws closed. Supply oil to the body with the jaws open.
- Be sure to supply oil to all of the six grease nipples.

2. Grease to use

- Use the designated grease specified in Table 6. If grease other than the designated grease is used, sufficient effect may not be obtained.

Table 6

Genuine product	CHUCK GREASE PRO	Kitagawa genuine product (Kitagawa distributor of each country)
Conventional product	Kitagawa chuck grease	Conventional product
	Molykote EP Grease	TORAY Dow Corning (only inside Japan)
	Chuck EEZ grease	Kitagawa-Northtech Inc. (North American region)
	MOLYKOTE TP-42	Dow Corning (Europe, Asian region)
	Klüberpaste ME31-52	Klüber lubrication (worldwide)

3. Frequency of lubrication

- Supply oil to the master jaws at least once a day, and to the body at least once a week.
- In the case of high rotation or in the case of using a large amount of water soluble coolant, increase the frequency of lubrication according to the usage conditions.



- **To keep the chuck running in the best condition for a long time, adequate grease lubrication is necessary. Insufficient grease lubrication causes a drop in the gripping force, operation failure at low hydraulic pressure, drop in gripping precision, abnormal wearing, seizing, etc. The work will fly out due to a drop in the gripping force and this is dangerous.**

4. Safety information about grease and anti-rust oil

Applicable range

- Designated grease
- Antirust agent applied to the product at the delivery.

First aid measures

After inhalation: Remove victim to fresh air. If symptoms persist, call a physician.

After contact with skin: Wash off with mild cleaners and plenty of water. If symptoms persist, call a physician.

After contact with eyes: Rinse with plenty of water. If symptoms persist, call a physician.

After ingestion: If large amounts are swallowed, do not induce vomiting. Obtain medical attention.

- Please refer to each MSDS about the grease and the anti-rust oil which you prepared.

7-3. Disassembling

Disassembling procedures

Read the following disassembling procedures with reference to pages 8-10.

1. Turn off the main power of the machine before starting work.
2. Loosen the jaw attaching bolt [25] and remove the soft jaw [08] and T-nut [09].
3. Loosen the chuck attaching bolt [26] and remove the chuck from the spindle.
4. Loosen the cap screw [29] and remove the sleeve cover [06].
5. Loosen the cap screw [27] and remove the flange [03].
6. Loosen the cap screw [28] and remove the piston [04].
7. Loosen the cap screw [30] and remove the cylinder cover [11].
8. Remove the wedge plunger [05] to the chuck rear side.
9. Remove the master jaw [07] to the inner periphery side of the chuck. At this time, only for No.1 jaw, remove the master jaw while pulling the pilot spool [17] toward the rear of the chuck.
10. Assemble again while sufficiently coating the recommended grease in the reverse procedures of disassembling. At this time, pay sufficient attention so as not to make a mistake in the numbers of the body [02], master jaw [07], and the wedge plunger [05].
11. Refer to page 43 about the installation procedure. (9. Attachment).

CAUTION

- Use an eyebolt or a hanging belt when attaching and detaching the chuck to and from the machine, as there is a danger of injury or damage if the chuck drops.

Type	Eye bolt
UPR450	M12
PR600, UPR650	M20
UPR710	M24
UPR910	M30

WARNING

- Remove the eyebolt or the belt without fail after using. If the chuck is rotated with the eyebolt, etc., attached, they may fly out and this is dangerous.
- Only experienced and trained personnel should do disassembling or assembling. Disassembling / assembling by a person who has never received instruction from an experienced person, the distributor or our company may cause a serious accident.
- Disassemble and clean the chuck at least once every 6 months or every 100,000 strokes (once every 2 months or more for cutting cast metal). If cutting powder or other substances stagnate inside the chuck, it will lead to insufficient stroke and a drop in the gripping force, and this is dangerous as the work will fly out. Check each part carefully and replace any part that is worn or cracked.
- If the workpiece slips during machining, the cause must be found out by disassembling and cleaning the chuck. Particularly, if dust enters the lock valve, the gripping force is reduced, causing the workpiece to fly out.
- When disassembling the chuck, operate the chuck so that the master jaws are closed, and loosen slowly the cap screw at the front of chuck body to discharge the air completely from the cylinder. Removing the plugs with internal pressure remained causes the chuck parts to fly out.
- After inspection, apply sufficient grease in the designated areas and reassemble.
- After assembling, measure the gripping force according to the method on page 21, and check that the specified gripping force is obtained.
- If you stop the machine for a long period of time, remove the work from the machine. If you don't, the work can drop due to a drop in the pneumatic pressure or malfunction.
- If you stop the machine or store the chuck for a long period of time, add grease to prevent rust.

8. Malfunction and Countermeasures

8-1. In the case of malfunction

Check the points specified in the table below and take the appropriate countermeasure.

Table 7

Problem	Cause	Countermeasure
Chuck does not operate	Chuck internal part is broken.	Disassemble, and replace broken part.
	Slideways get seized	Disassemble, and correct the seized part with an oilstone, or replace the part.
	Compressed air is not supplied normally.	Correct problems in the piping systems including the air source, lubricator, pressure reducing valve, switching valve, or replace them.
	Wear or damage of the air supply ring, diaphragm packing, and cylinder O-ring	Disassemble, and replace the part.
	Faulty lock valve	Disassemble and clean it, or replace the part.
Lack of jaw stroke	Many chips exist in jaws.	Disassemble and clean the jaws.
The workpiece slips	Lack of jaw stroke	Adjust the top jaw position so that it is around the center of stroke when gripping the workpiece.
	Lack of gripping force	Check that the setting air pressure is correct.
	The formed diameter of the top jaw does not match the workpiece diameter.	Reform the jaw according to the correct forming method.
	Excessive cutting force	Calculate cutting force and check that it is appropriate for the chuck specification.
	Lack of grease	Supply grease from grease nipple, and open and close the jaws several times without gripping the workpiece.
	Excessive top jaw weight causes excessive loss of gripping force during high-speed rotation.	Remove unnecessary part of the top jaw to reduce the weight. (Pay attention to the strength of the top jaw.)
	Excessive rotation speed. Runout due to misalignment of the work feeder, steady rest, tailstock, etc.	Slow down the rotation speed to obtain required gripping force. Thoroughly conduct alignment to eliminate runout.
	Air leaks from the lock valve.	Remove the cap screw on the chuck body and measure air pressure. Replace the O-ring on the lock valve or the whole lock valve.
	Wear of cylinder O-ring	Disassemble, and replace the O-ring.
Accuracy failure	Chuck circumference runs out.	Check the circumference and end face for runout and retighten the chuck mounting bolts.
	Dust accumulates in serration parts of master jaw and top jaw.	Remove the top jaw and thoroughly clean the serration part.
	Top jaw mounting bolts are not sufficiently tightened.	Tighten the top jaw mounting bolts with the specified torque. (See P-15)
	Soft jaws are formed inadequately.	Check that the forming plug is parallel to the chuck end face and check the plug for deformation due to gripping force. Also, check the air pressure during formation and surface roughness of the forming part.
	Due to excessive top jaw height, the top jaw is deformed and the top jaw mounting bolts are extended.	Lower the top jaw height. (Replace with standard size.) Check the gripping contact surface and make it even.
	Excessive gripping force deforms workpiece.	Reduce the gripping force to the extent that machining can be executed to prevent deformation.

 **WARNING**

- In case that the chuck failed to operate due to a seizure or breakage, remove the chuck from the machine following the reverse procedures of “9. Attachment” on page 40. When the jaws and covers cannot be removed due to a blockage of workpiece, do not disassemble forcibly but please contact us or our agent.
- If these countermeasures do not correct the problem or improve the situation. Immediately stop using the machine. Continuous use of a broken product or a defective product may cause a serious accident by the chuck or the work flying out.
- Only experienced and trained personnel should do repairs and fix malfunctions. Repair of a malfunction by a person who has never received instruction from an experienced person, the distributor or our company may cause a serious accident.

8-2. Where to contact in the case of malfunction

In the case of malfunction, contact the distributor where you purchased the product or our branch office listed on the back cover.

For Machine Tool Manufactures

Following pages are described for machine tool manufacturers (personnel who attach a chuck to a machine). Please read following instruction carefully when you attach or detach a chuck to machine, and please sufficiently understand and follow the instructions for safe operation.

9. Attachment

9-1. Outline drawing of attachment

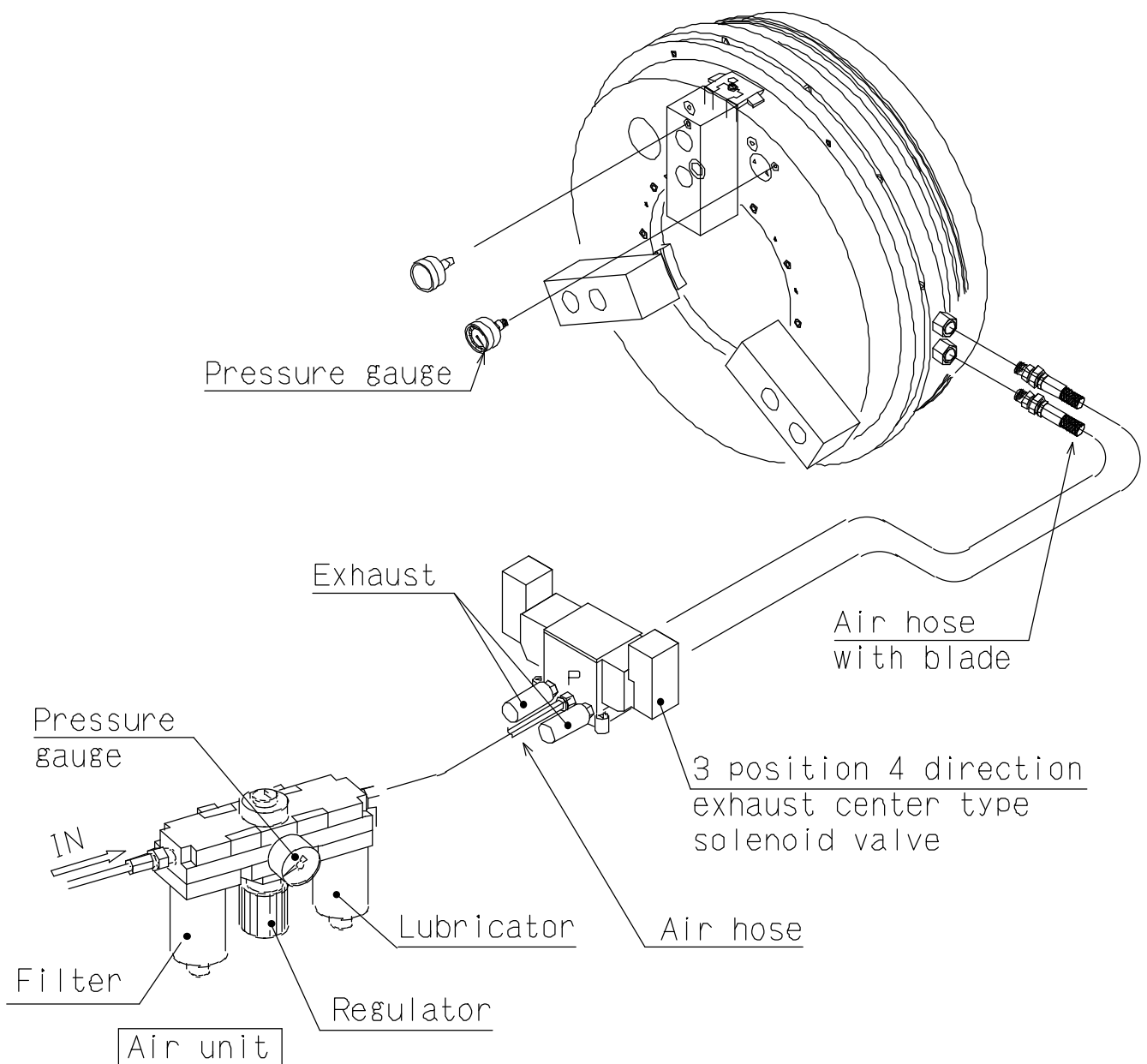

Fig.14

9-2. Manufacturing and attaching of back plate and support

NOTICE

- Run-out of the back plate directly affects the process precision. The end surface run-out of the back plate, spigot joint diameter run-out must be 0.02 mm or less. (Refer to Fig.15)
- Provide a support to secure the air supply ring to the lathe body. Refer to the Delivery Specification for the dimensions. For dimension A in Fig.15, consideration must be given so that the tolerance can be adjusted to within ± 0.1 .
- Provide an air escape hole (over $\phi 40$) underneath the support as shown in Fig.15. This hole escapes the air coming out of a gap between supply ring and chuck. The jaw operating speed slows unless the hole is provided.

DANGER

- **Adjust the runout occurring when the support and the air supply ring are mounted to be less than the value shown in Fig.15. Check that the clearance between the air supply ring and the body is 0.5 ± 0.2 mm. If the air supply ring comes into contact with the body, seizure may occur during chuck rotation.**
- **Always tighten the bolts at the specified torque. If the torque is insufficient or excessive, the bolt will break, which is dangerous as the chuck or work will fly out.**

Table 8

Bolt size	Tightening torque	
M5	7.5	N·m
M6	13	N·m
M8	33	N·m
M10	73	N·m
M12	107	N·m
M14	171	N·m
M16	250	N·m
M20	402	N·m
M22	539	N·m
M24	666	N·m

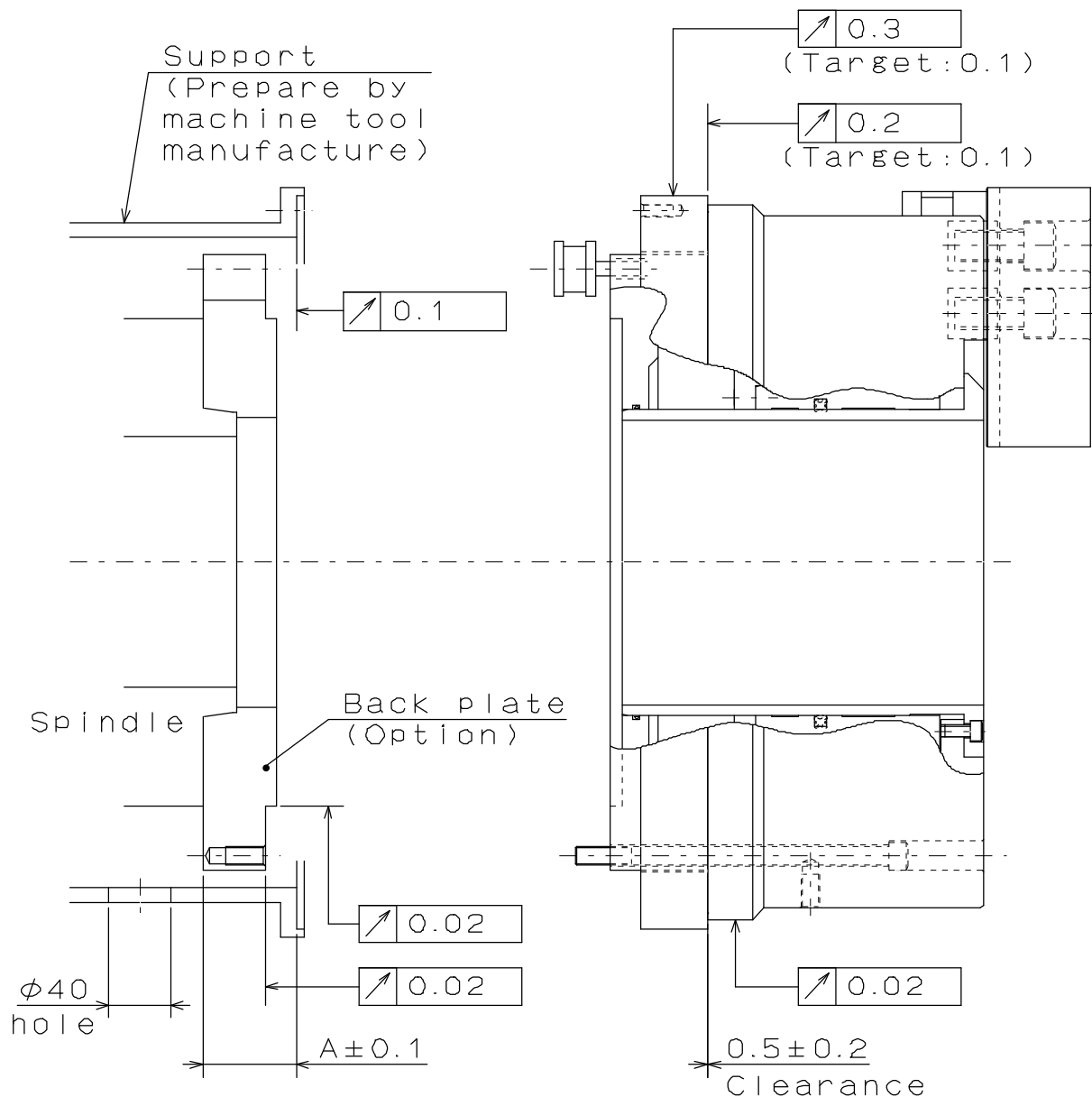

Fig.15

CAUTION

- Use an eyebolt or a hanging belt when attaching and detaching the chuck to and from the machine, as there is a danger of injury or damage if the chuck drops.

WARNING

- Remove the eyebolt or the belt without fail after using. If the chuck is rotated with the eyebolt, etc., attached, they may fly out and this is dangerous.

9-3. Piping

For the air circuit diagram, refer to Fig.16.

- Be sure to use exhaust center type solenoid valve of 3-position and 4-direction.
- The piping connection bore is according to sizes as shown in table 9. Route the air hose of size shown in table 9. Also, route the pipe of the short piping length as much as possible and don't use the piping having many elbows. Use the air hose with blade between chuck and solenoid valve.
- Remove foreign mater and dust inside of piping before routing.
- Attach the pressure gauge at the place for operator to be easily watched and adjusted.

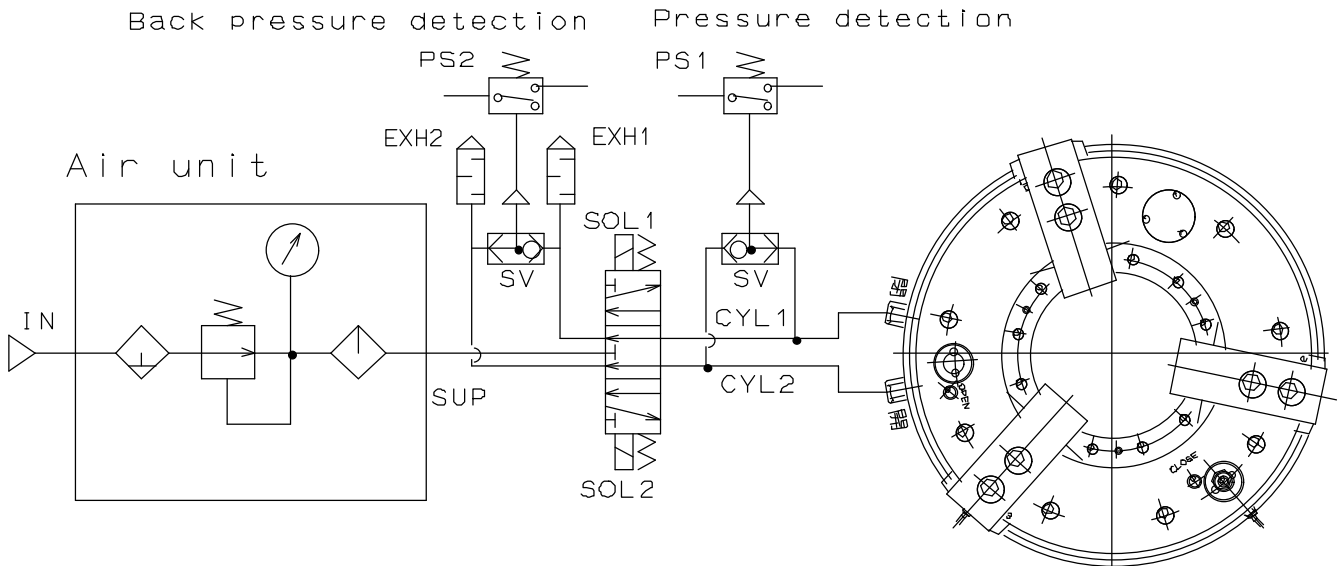

Fig.16

Table 9

Item \ Type	UPR450 - UPR600	UPR650 - UPR910
Pipe diameter (mm)	9.5 or more	13 or more
Connection diameter	Rc 3/8	Rc 1/2

9-4. Precautions related to pneumatic pressure

DANGER

- Do not supply air during spindle rotation. If air is supplied during spindle rotation, the diaphragm packing in the air supply ring will be damaged and the gripping force will be lost, causing the workpiece to fly out. For fail-safe operation, such circuit must be designed that air cannot be supplied during spindle rotation.
- If switching valve gripping operation is performed, the jaws immediately operate to grip the workpiece. However, appropriate gripping force is not generated until the chuck internal pressure is stabilized at the setting pressure. Such circuit must be designed that air is supplied for sufficient time to generate appropriate gripping force. If the chuck internal pressure does not reach the setting pressure, the gripping force is lost, causing the workpiece to fly out. (Remove the cap screw from the chuck surface and install the pressure gauge attached, and then check the time until the chuck internal pressure reaches the setting pressure during air supply.)

NOTICE

- Design the chuck to perform orientation so that the phases of the rotation part and the fixed part of the chuck are aligned to those specified when air is supplied to the chuck. At other phases, air is not supplied and the chuck cannot operate. The phases differ depending on the chuck size and specification. Refer to the Delivery Specification.

9-5. Electric circuit diagram for reference

The sequence circuit using the pressure switch of push button is shown in Fig.17.

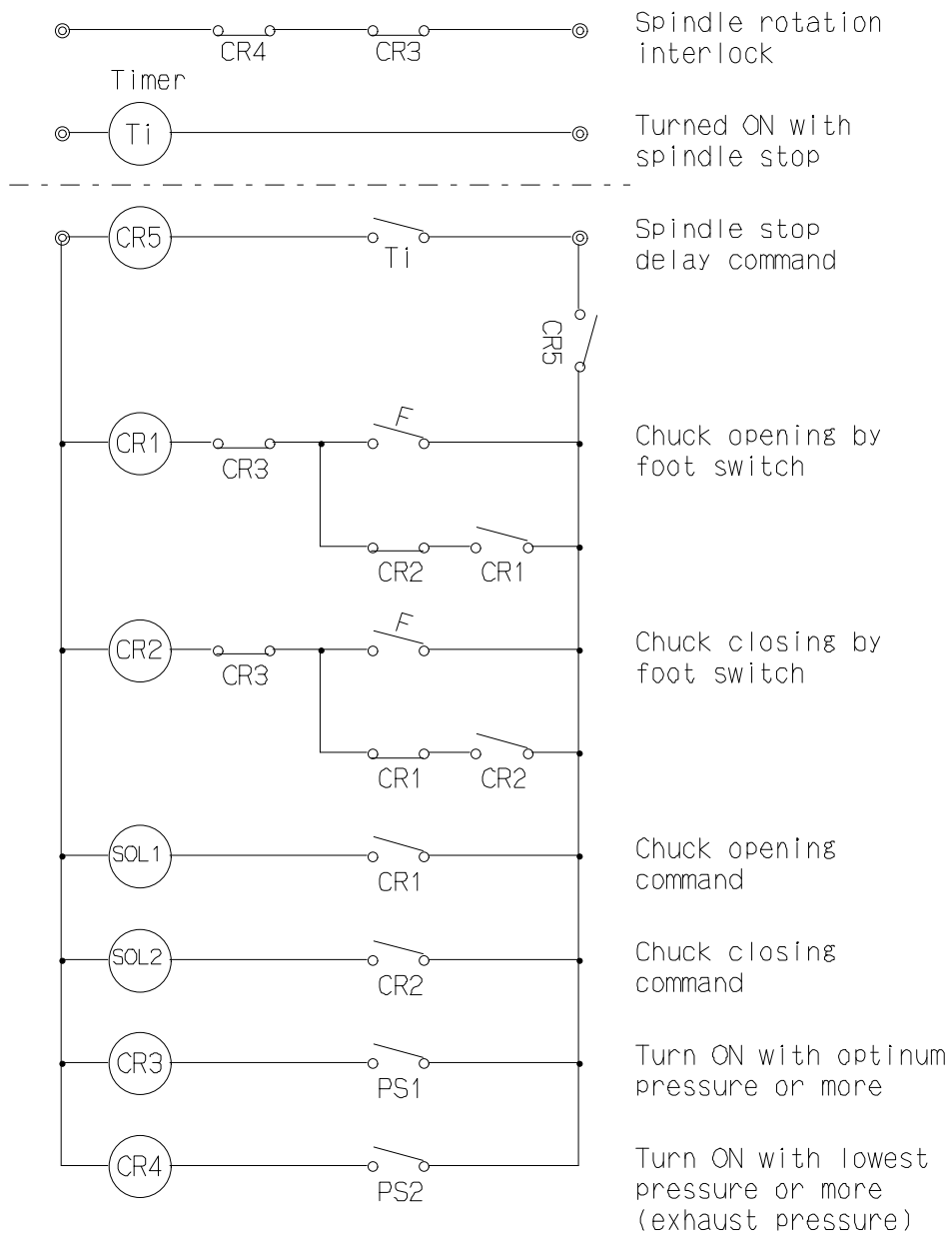

Fig.17

- Prepare the diagram so that the chuck dose not operate during spindle rotation.
- Since the spindle, chuck, work, etc., are immediately stopped by inertia.
- The above PS2 is for lowest pressure detection and CR4 mode allows the spindle not to start if exhaust pressure remains in to the air supply hose for the chuck. PS1 is for optimum pressure detection and the optimum pressure is required to set in accordance with the work. When the pressure reaches the optimum pressure, CR3 actuates to open the SOL circuit.

9-6. Jaw stroke detection

The detectable plate for jaw stroke detection is built in the UPR air chuck and operates in synchronization with the jaw stroke. It prevents gripping failure by detecting the motion with the proximity switch.

As shown in Fig.18-(1), when the jaws are opened, the detectable plate moves toward the rear of the chuck. Also, as shown in Fig.18-(2), when the jaws are closed, the detectable plate moves toward the front of the chuck.

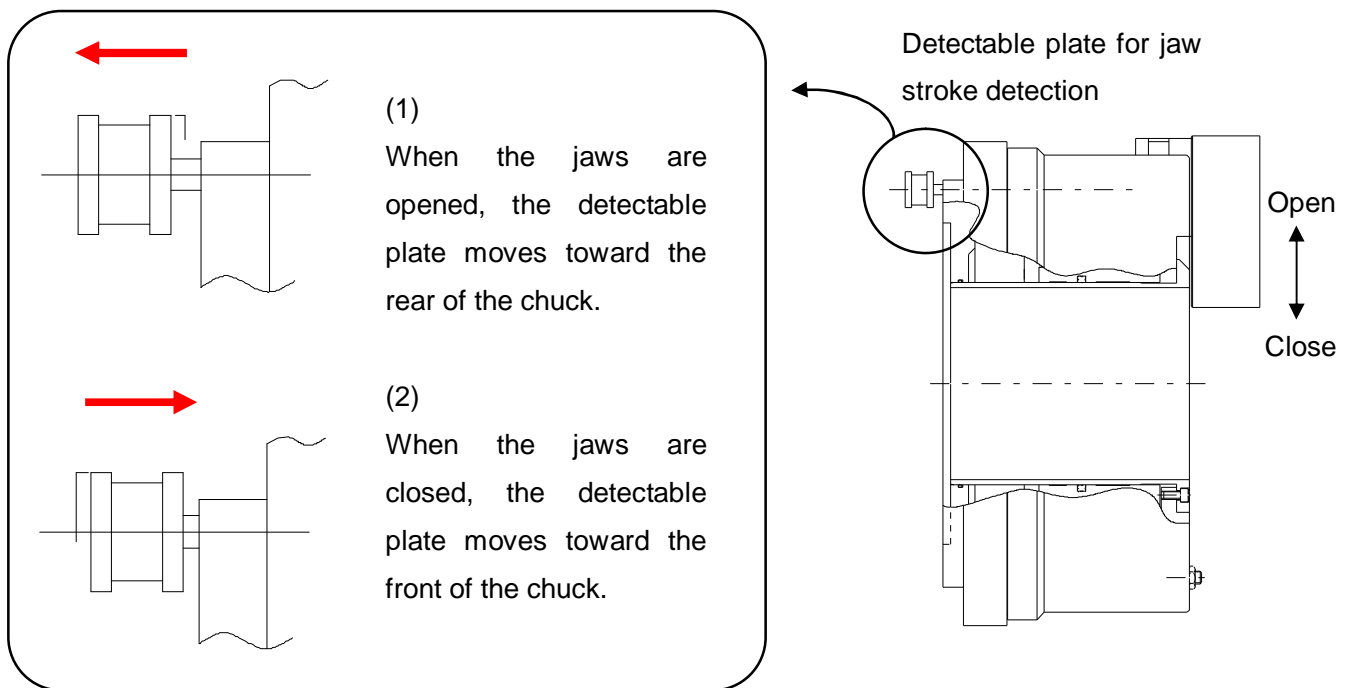

Fig.18

Proximity Switch

The chuck must stop at the home position to detect the jaw stroke.

Install the proximity switch in the position where it can detect the dog from the circumference of support. In such a case, cover the switch to protect it from the chips and coolant.

9-7. Chuck inner pressure detection

The detectable plate for chuck decompression is built in the UPR air chuck and operates when the chuck internal pressure of the jaw close side is reduced. By detecting the motion with the proximity switch, it prevents the workpiece from flying out due to reduced gripping force.

As shown in Fig.19-(1), when air is supplied to the jaw close side, the internal pressure surpasses the spring and the detectable plate moves toward the front of the chuck. Also, as shown in Fig.19-(2), when the internal pressure of the jaw close side is reduced to a given value, the detectable plate is moved toward the rear of the chuck by the spring.

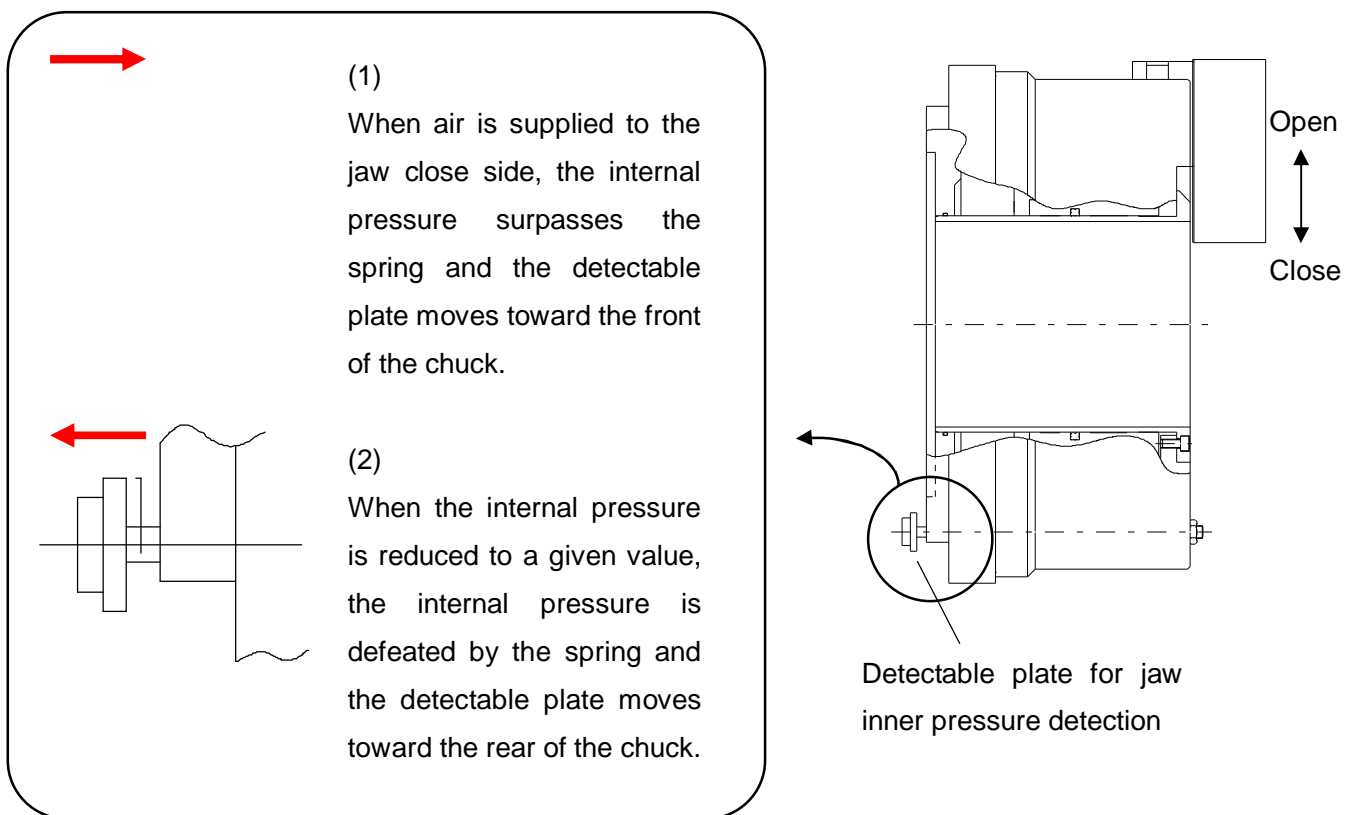

Fig.19

The detection of chuck decompression is possible only when the supplied air pressure exceeds 0.35MPa (factory default setting).

When the air is supplied to the chuck, the dog moves 4mm till the chuck forward stroke end before the supplied air pressure reaches 0.35MPa. When the air pressure in the chuck is reduced, the dog moves 4mm till the chuck rear (spindle side) stroke end before the internal air pressure reaches 0.175 – 0.225MPa.

NOTICE

The spring determines the working pressure of the detectable plate. Therefore, particularly if air is supplied at high pressure, the detectable plate may perform momentary reciprocating motion at the moment when air is supplied as shown in Fig.20. To prevent the proximity switch from detecting the momentary reciprocating motion of the detectable plate shown in Fig.20, please give consideration to keep the proximity switch from detecting for a few seconds just after air is supplied by using a timer, etc.

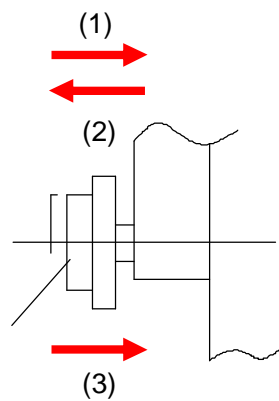

At the moment when air is supplied, the detectable plate momentarily moves toward the front of the chuck.

Immediately it goes back to the initial rear position.

Then, the detectable plate moves slowly toward the front of the chuck and stops. (Internal pressure is maintained.)

Fig.20

Proximity Switch

The chuck must stop at the home position to detect the chuck decompression. Install the proximity switch in the position where it can detect the dog from the circumference of support. In such a case, cover the switch to protect it from the chips and coolant.

Adjusting chuck decompression detection start pressure

As shown in Fig.21, the spring force of the internal pressure detection unit can be changed by tightening the lock screw, and the chuck decompression detection start pressure can be adjusted. The detection start pressure increases as the lock screw is tightened. The pressure decreases as the screw is loosened.

When the adjustment is completed, lock the lock screw with the nut.

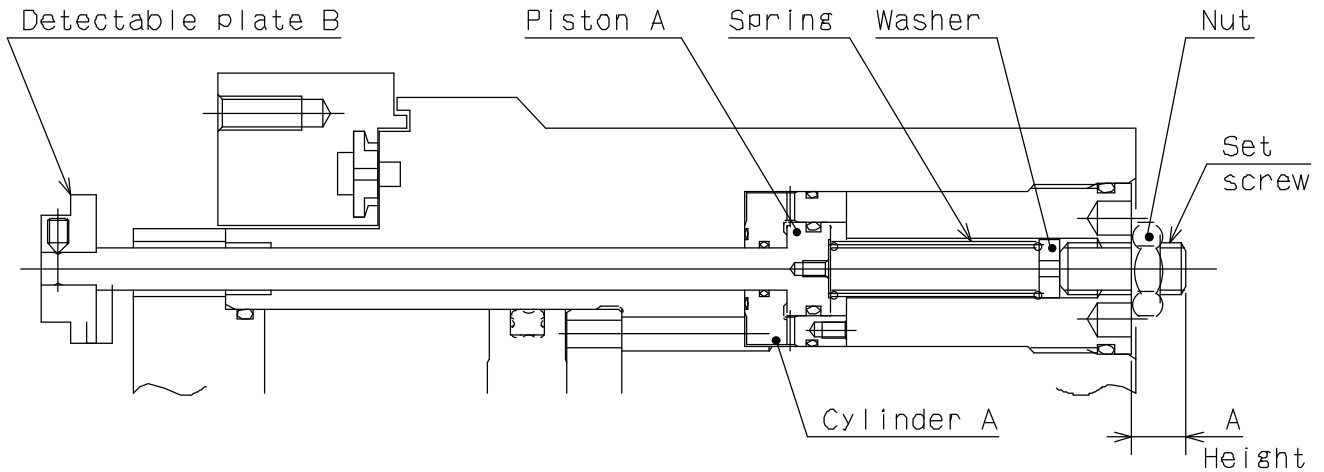

Fig.21

Table 10

Set screw	M12 × 30	M12 × 30	M12 × 35
Height (mm)	13	10	12
Avarable pressure (MPa)	0.35	0.40	0.45
Detection start pressure (MPa)	0.20	0.25	0.30

10. Other information

10-1. About standards and orders

This product is based on the following standards or orders.

- Machinery directive:2006/42/EC Annex I
- EN ISO 12100-1:2003+A1:2009
- EN ISO12100-2+A1:2009
- EN ISO14121-1:2007
- EN1550:1997+A1:2008

10-2. Information about markings of product

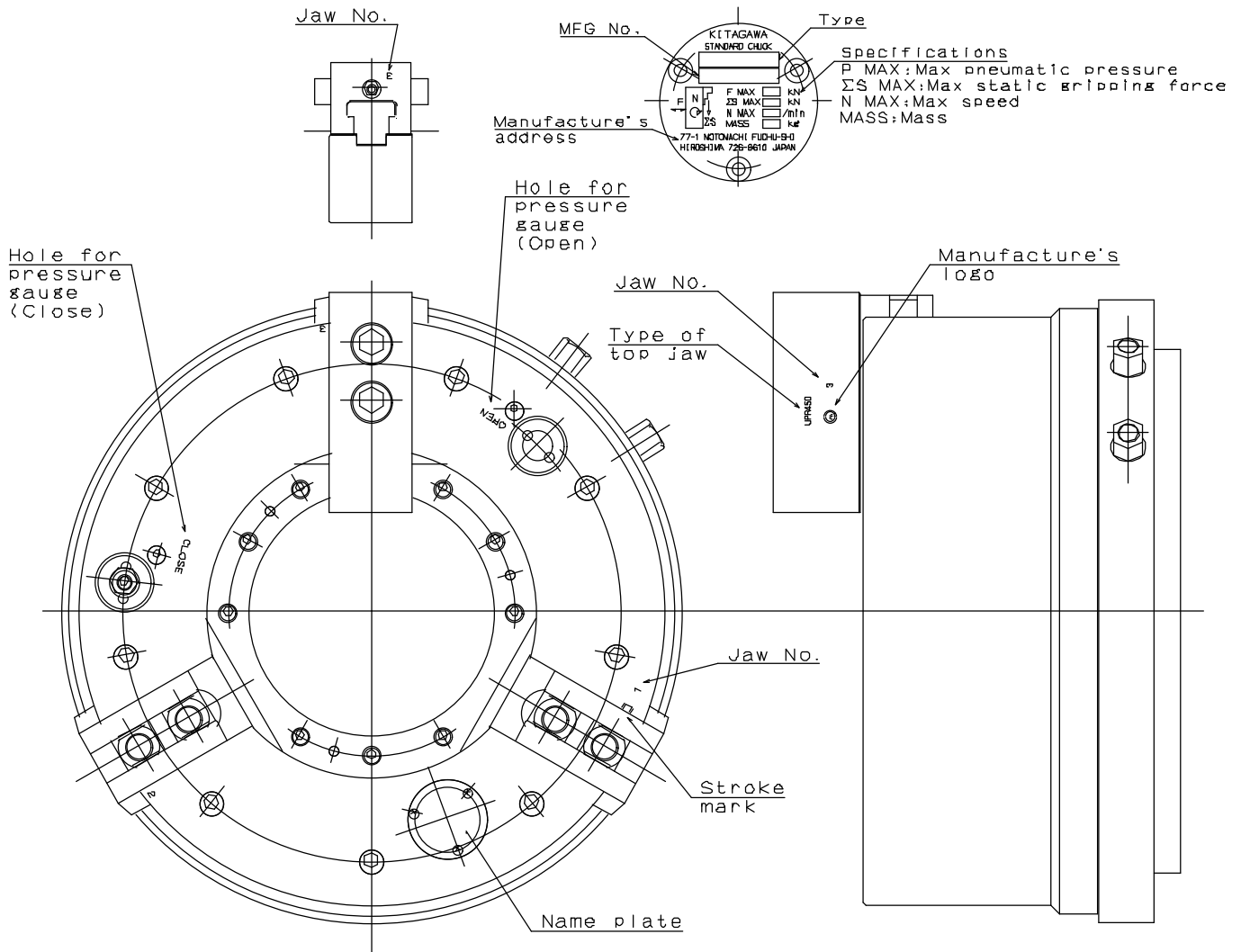

Fig.22

10-3.About disposal

Ultimate disposal of this product should be handled according to all national laws and regulations.



<http://www.mta.kiw.co.jp>

KITAGAWA IRON WORKS CO., LTD.

77-1 Motomachi Fuchu-shi, Hiroshima-pref., 726-8610, Japan

TEL +81-847-40-0526 FAX +81-847-45-8911

America Contact	KITAGAWA-NORTHTECH INC. http://www.kitagawa.com 301 E. Commerce Dr, Schaumburg, IL. 60173 USA TEL +1 847-310-8787 FAX +1 847-310-9484
Europe Contact	KITAGAWA EUROPE LTD. http://www.kitagawaeurope.com Unit 1 The Headlands, Downton, Salisbury, Wiltshire SP5 3JJ, United Kingdom TEL +44 1725-514000 FAX +44 1725-514001
	KITAGAWA EUROPE GmbH http://www.kitagawaeurope.de Reeserstrasse 13, 40474, Dusseldorf Germany TEL +49 211-550294-0 FAX +49 211-55029479
	KITAGAWA EUROPE GmbH Poland Office TEL +48 607-39-8855 FAX +48 32 -749- 5918
Asia Contact	KITAGAWA INDIA PVT LTD. Lotus House East, Lane 'E' North Main Road, Koregaon Park, Pune, 411001, Maharashtra, India Tel: +91 20 6500 5981 FAX +91 20 2615 0588
	KITAGAWA (THAILAND) CO., LTD. Bangkok Office 9th FL, Home Place Office Building, 283/43 Sukhumvit 55Rd. (Thonglor 13),Klongton-Nua, Wattana, Bangkok 10110, Thailand TEL +66 2-712-7479 FAX +66 2-712-7481
	KITAGAWA IRON WORKS CO., LTD. Singapore Branch #02-01 One Fullerton, 1 Fullerton Road, Singapore 049213 TEL +65 6838-4318 FAX +65-6408-3935
	KITAGAWA IRON WORKS (SHANGHAI) CO., LTD. Room308 3F Building B. Far East International Plaza,No.317 Xian Xia Road, Chang Ning, Shanghai, 200051China TEL +86 21-6295-5772 FAX +86 21-6295-5792
	DEAMARK LIMITED http://www.deamark.com.tw No. 6, Lane 5, Lin Sen North Road, Taipei, Taiwan TEL +886 2-2393-1221 FAX +886 2-2395-1231
	KITAGAWA KOREA AGENT CO., LTD. http://www.kitagawa.co.kr 803 Ho, B-Dong, Woolim Lion's Valley, 371-28 Gasan-Dong,Gumcheon-Gu, Seoul, Korea TEL +82 2-2026-2222 FAX +82 2-2026-2113
Oceania Contact	DIMAC TOOLING PTY LTD. http://www.dimac.com.au 61-65 Geddes Street, Mulgrave, Victoria, 3170 Australia TEL +61 3-9561-6155 FAX +61 3-9561-6705

The products herein are controlled under Japanese Foreign Exchange and Foreign Trade Control Act. In the event of importing and/or exporting the products, you are obliged to consult KITAGAWA as well as your government for the related regulation prior to any transaction.

2012.02.